

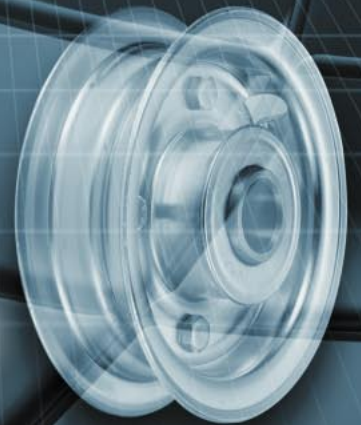

UKAI PRODUCTS

Casters & Wheels

General Catalog E2014-1



Gifu Sanken Kogyo Co.,Ltd.



It is us that supplies the best UKAI casters.

Wheels for various industries, UKAI brand casters and wheels, known and loved locally and internationally, are highly evaluated with their quality and performance.

Casters and wheels that support smooth movement are widely utilized in various industries as contribution of conveyance rationalization and lightened labor.

We strive to develop quality, and also we will keep our persistent efforts to create and develop our products with our advanced technique.



Casters & Wheels



■ Ogaki Factory / Caster Division



UKAI casters are manufactured in Ogaki Factory, and distributed inside Japan and also around the world.

■ The Usage Notice of Casters	P.5
■ The Model Number of UKAI Casters	P.7
■ Caster, Bracket and Wheel Parts	P.7
■ Basic data of Tire Material	P.8
■ RoHS Compliant	P.8
■ Caster Selection	P.9
■ Wheel Selection	P.11

■ Medium Weight Caster Series	Swivel Caster	J Type	P.15
	Rigid Caster	K Type	P.21
	Swivel Caster with Stopper	JB Type	P.27
	Rigid Caster with Stopper	KBZ Type	P.33

■ Stainless Steel Caster Series	Swivel Caster	JA Type	P.39
	Rigid Caster	KA Type	P.45
	Swivel Caster with Stopper	JAB Type	P.51
	Rigid Caster with Stopper	KABZ Type	P.57

■ Heavy Duty (Small Type) Caster Series	Swivel Caster (Small Type)	JM Type	P.63
	Adjuster	AD-12/AE-12 Type	P.64
	Rigid Caster (Small Type)	KH Type	P.65

■ Heavy Duty Caster Series	Swivel Caster	JM Type	P.67
	Rigid Caster	KH Type	P.69
	Swivel Caster with Stopper	JMB Type	P.71
	Super Heavy Duty Swivel Caster	JH Type	P.73
	Super Heavy Duty Swivel Caster with Stopper	JHB Type	P.75

■ Towing Caster Series	Swivel Caster	JHW Type	P.77
	Rigid Caster	KHW/KW Type	P.78

■ Low Height Caster Series	Swivel Caster	T Type	P.79
	Dust-Proof Swivel Caster	TN Type	P.80
	Heavy Duty Swivel Caster	TH Type	P.81
	Adjuster	AE Type	P.82

■ Medium Weight Wheel Series	Steel Rim	Polybutadiene Rubber Wheel	S Type	P.83
		Polybutadiene Red Rubber Wheel	SR Type	P.83
		Polybutadiene High-Rebound Rubber Wheel	SH Type	P.84
		Chloroprene Heat-resistance Rubber Wheel	CR Type	P.84
		Urethane Rubber Wheel	SUI Type	P.85
		Anti-Static Urethane Rubber Wheel	SUIE Type	P.85
	Nylon Rim	Polybutadiene Rubber	PN Type	P.86
		Polybutadiene Rubber (Including Stainless Steel Bearings)	PND Type	P.86
		Urethane Rubber	PNU Type	P.87
		Urethane Rubber (Including Stainless Steel Bearings)	PNUD Type	P.87
		Polybutadiene Rubber (Spindle Sleeve)	PNA Type	P.88
		Urethane Rubber (Spindle Sleeve)	PNUA Type	P.88
		Nylon	PB Type	P.89
		Nylon (Including Stainless Steel Bearings)	PBD Type	P.89
	Nylon (Spindle Sleeve)	P Type	P.90	
	Steel Rim	Polybutadiene Rubber (Including Radial Bearings)	SV Type	P.90
		Polybutadiene High-Rebound Rubber (Including Radial Bearings)	SHV Type	P.90



■ Heavy Duty Wheel Series	Reinforced Nylon	RGN Type P.91
	Polybutadiene Rubber	RG Type P.91
	Aluminum Rim • Urethane Rubber	R Type P.92
	Steel Rim • Urethane Rubber	RF Type P.92
	MC Nylon	RR Type P.93
	Aluminum Rim • MC Nylon	RR Type P.93
	MC Nylon	UWB Type P.94
	MC Nylon (Including Stainless Steel Bearings)	UWBD Type P.95
	MC Nylon (Spindle Sleeve)	UWA Type P.96
	MC Nylon [Slim Type]	UWBS Type P.97
	MC Nylon [Slim Type] (Including Stainless Steel Bearings)	UWBSD Type P.97
	Steel	F Type P.98
	Steel (Spindle Sleeve)	FA Type P.98
■ Medium Weight Caster Series	Swivel Caster	HJ Type P.99
	Rigid Caster	HK Type P.100
	Swivel Caster with Stopper	HJS Type P.101
	Steel Rim • Polybutadiene Rubber Wheel	H Type P.102
■ Silent Running Caster Series	Swivel Caster	PCJC Type P.104
	Rigid Caster	PCKE Type P.105
		PCKC Type P.106
	Swivel Caster with Stopper	PCJCS Type P.107
	Nylon Rim • Polybutadiene Rubber Wheel	PC Type P.108
■ Pneumatic Rubber / Airless Wheel Caster Series	Swivel Caster	HLJ/HFJF Type P.111
	Rigid Caster	HLK/HFKF Type P.113
	Swivel Caster with Stopper	HLJB/HFJBF Type P.115
■ Pneumatic Rubber / Airless Wheel		6½×2-3HL P.116
		6½×2-4HL P.117
		6½×2-4HF P.117
		2.00-4HL P.118
		2.50-4HL P.118
		3.00-4HL P.119
		8×3.00-4HL P.119
		3.50-5HL P.120
		Pneumatic Wheel Parts P.121
		The Model Number of UKAI Pneumatic Wheels P.121
	The Usage Notice of Pneumatic Wheels P.121	

■ The Performance Test of Casters P.122
-----------------------------------	-------------

The Usage Notice of Casters

(I) Application

Casters are attached to transportation equipment and other devices inside rooms and facilities, with the purpose of facilitating the relocation or transfer of cargoes, excluding people and animals, and moved by human power intermittently.

(II) Choice of the Casters and Usage Conditions

1. Load Capacity and Adequate Load

Load Capacity Upper limit for safe, smooth use for a long period of time

Adequate Load When casters are attached to a cart (use of 4 casters), the load needs to be supported at 3 points. Accordingly, please calculate the load, assuming 80% of the maximum load, as shown in the following equation:

$$\text{Adequate Load} = \text{Load Capacity per 1 pcs (daN)} \times 4 \text{ pcs} \times 0.8$$

*About a Unit.

1daN=10N \approx 1.02kgf (1kgf \approx 9.8N=0.987daN)
(Scale factor:9.8 \rightarrow 9.80665)

2. Speed Limits

Use the casters intermittently on a flat road at less than the speed tabulated below. This is the same also for using casters for towing, and using the power of a trailer or the like. Please avoid the continuous use, which generates heat.

Wheel Diameter	Speed Limits
Below 75mm	Below 2km/h
Above 100mm	Below 4km/h

3. Usage Conditions

Please determine the following items, according to equipment (loading and usage conditions).

Type of Bracket Swivel, Rigid, With Stopper, etc.
Installation Method, Material

Type of Wheel Diameter, Material

4. Usage Environment

In general, casters are designed, assuming that they are used indoors at room temperature. Please avoid exposure to the caustic environment (Ex.acidity, alkali, sea, oil). There is a risk that products will deteriorate.

If you want to use the casters at high or low temperatures, please consult with us. You would require brackets, wheels, and grease according to usage.

Some materials of the wheels may stain floor surfaces.

5. Stopper

Long-term abrasion or damage may degrade the functions before you notice. In addition, hard wheels, such as nylon wheels, have less braking force, from shipment.

If necessary for safety, please take measures, such as wheel clamps and floor locks, to complement the braking performance.

(III) Installation of Casters

1. Attach each caster to the fixated joint part properly with a bolt, a nut, a washer, etc. that fits the hole part for attaching, so that it will not loosen.
2. Attach each caster so that the attachment plane is horizontal.
3. Attach each swivel caster so that the swivel axis is vertical.
4. Attach rigid casters so that they are parallel to each other.

(IV) The Usage Notice

1. Setting Condition

Please do not use the products for any purposes other than those specified in the setting conditions, because they could place excessive burdens on casters, leading to deformation and damage.

- Please avoid overloading.
- Please avoid partial loading.
- Please do not use the casters with incorrect and unsecure fitting and installation.
- Please avoid excessive shock load (Please be cautious about the shocks from steps and loading goods).
- Please do not use the casters on a significantly uneven surface and move them across over a sharp protrusion.
- Please do not move the cart forward to the opposite direction of its rigid casters.
- Please do not use the casters using the power of a trailer, excluding when using towing casters.
- Please do not place a person or animal on a cart with casters.
- Please do not attach casters to a cart for the purpose of moving people or animals.

2. Stopper

Since a stopper may loosen unexpectedly due to a shock, please avoid the following operations.

- Please use the stopper pedal surely with the foot while wearing shoes.
- Please do not park the cart on a slope even if the caster stoppers are locked.
- Please do not move the cart when the caster stoppers are locked.
- Please do not step on the stopper pedals too hard or knock the pedals with a hammer.
- Please do not use the stopper pedal during driving.

3. Handling of the Casters

Use protective gears, such as gloves, to handle casters safely.

4. Remodeling of the Product

We will not take responsibility for the remodeling, reassembly, coating, welding, and attachment conducted by you. We would appreciate your understanding.

(V) Maintenance Checkup

Deterioration, including the loosening of screws and the corrosion of parts, may occur according to usage conditions and period. Check the following items regularly.

- Whether the caster mounting part is clamped tightly
If not, clamp it again.
- Swivel Part of Swivel Casters
If you find the swaged part has loosened, replace swivel casters.
- Whether the caster/shaft part has loosened or corroded
If you find screws have loosened, tighten them. If you find corroded parts, replace the parts.
- Whether there is the abrasion or deterioration of the tire part, the corrosion of the bearing part, or the like
If you find deteriorated parts, replace the parts.
- Whether there are foreign materials in the swivel or shaft part
If there are any foreign materials, remove them.
- Whether there are any damage, cracks, or deformation
If any, replace the parts.

As for pneumatic rubber / airless wheel, please refer to "The Usage Notice of Pneumatic / Airless Wheels" on page 121

If there are any questions, please ask us before use.

Warning



The following usage is prohibited.

Wrong usage could lead to a serious accident.

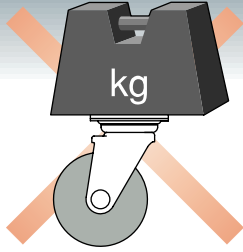

Please avoid overloading.

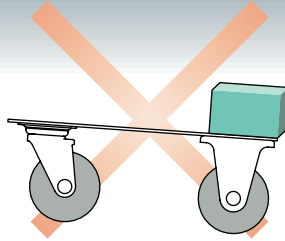

Please avoid partial loading.

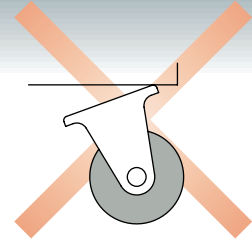

Please do not use the casters with incorrect and unsecure fitting and installation.

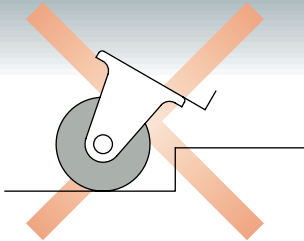

Please avoid excessive shock load (Please be cautious about the shocks from steps and loading goods).

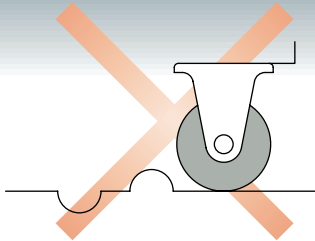

Please do not use the casters on a significantly uneven surface and move them across over a sharp protrusion.

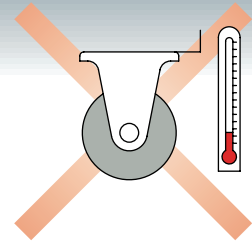

Please avoid exposure to the caustic environment (Ex.acidity, alkali, sea, oil), and do not exceed the specified temperature.

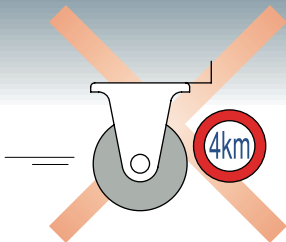

Please do not exceed the following speed limits.

Wheel Diameter	Speed Limits
Below 75mm	Below 2km/h
Above 100mm	Below 4km/h

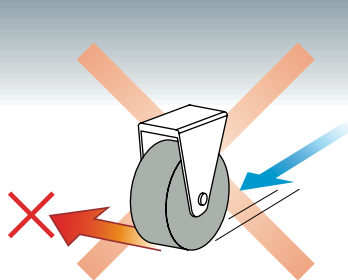

Please do not move the cart forward to the opposite direction of its rigid casters.

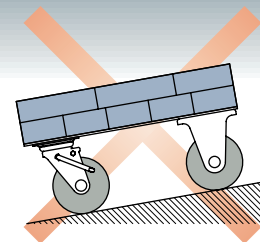

Please do not park the cart on a slope even if the caster stoppers are locked.

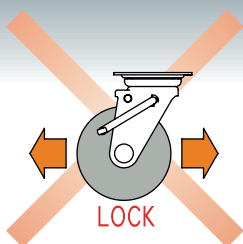

Please do not move the cart when the caster stoppers are locked.

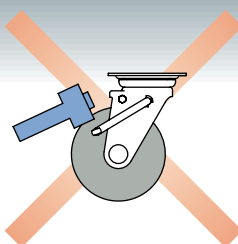

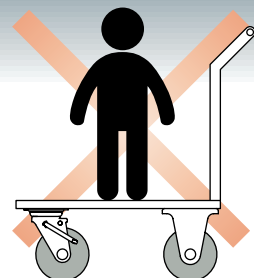

Please do not step on the stopper pedals too hard or knock the pedals with a hammer.





Please do not place a person or animal on a cart with casters.

The Model Number of UKAI Casters

The Model Number of UKAI Casters

S	J	-	150	 <p>SJ-150</p>
150mm Medium Weight Rubber Wheel with Swivel Bracket				
RR	JM	-	150	 <p>RRJM-150</p>
150mm Heavy Duty MC Nylon Wheel with Swivel Bracket				
Wheel Type P.11/P.12	Bracket Type P.9/P.10	-	Wheel Size (mm)	

The Model Number of UKAI Wheels

S	-	150	 <p>S-150</p>
150mm Rubber Wheel			
RR	-	150	 <p>RR-150</p>
150mm MC Nylon Wheel			
Wheel Type P.11/P.12	-	Wheel Size (mm)	

Build-to-order manufacturing Ordinarily, the turnaround time is 30 to 60 days. For details, please ask us when placing an order.

Caster, Bracket and Wheel Parts

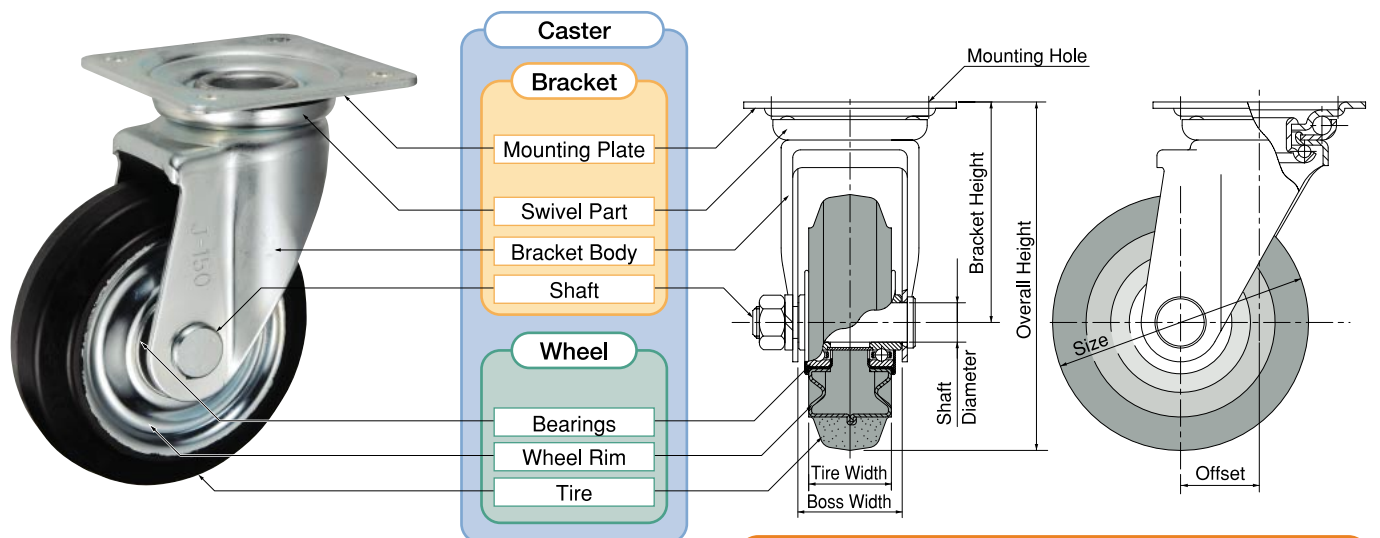

As for pneumatic rubber / airless wheel, please refer to page 121.

Basic Data of Tire Material

Tire Material	Natural Rubber	Polybutadiene Rubber	Polybutadiene High-Rebound Rubber	Polybutadiene Red Rubber
Model Number of Wheel	—	S·PN·PNA·PND·RG·H·PC	SH	SR
Hardness	HS80	HS65	HS58	HS60
Elasticity	○	☆	☆	☆
Compression Set	○	○	○	○
Wear-resistance	○	◎	◎	◎
Weather-resistance	○	○	○	○
Oil Proof (Machine Oil)	△	△	△	△
Gasoline-resistance	×	×	×	×
Heat-resistance (°C)	90	80	80	80
Cold-resistance (°C)	-20	-40	-20	-20
Water-resistance	○	△	△	△
Chemical-resistance (Acidity, Alkali)	△	△	△	△
Starting Resistance	○	◎	☆	◎

Tire Material	Chloroprene Heat-resistance Rubber	Polyurethane Rubber (thermosetting)	Nylon	Monomer Cast Nylon
Model Number of Wheel	CR	SUI·SUIE·PNU·PNUA·PNUD·RF·R	P·PB·PBD·RGN	RR·UWB·UWBS·UWA·UWBD·UWBSD
Hardness	HS70	HS95 (SUIE:HS90)	HR120	HR120
Elasticity	○	◎	×	×
Compression Set	○	☆	△	◎
Wear-Resistant	◎	☆	○	☆
Weather-Resistant	○	☆	☆	☆
Oil Proof (Machine Oil)	△	☆	☆	☆
Gasoline-Resistant	△	◎	◎	◎
Heat-Resistant (°C)	100	70	70	130
Cold-Resistant (°C)	-20	-30	-40	-40
Water-Resistant	△	△	○	○
Chemical-Resistant (Acidity, Alkali)	○	×	◎	◎
Starting Resistance	○	☆	◎	☆

* Hardness HS:Shore hardness, HR:Rockwell hardness ☆ : Excellent ◎ : Very Good ○ : Good △ : Acceptable × : Improper

* General characteristics of materials only. Please refer to them when selecting or judging materials, because the products are influenced by usage conditions and environments.

* If you use the products outside the above temperature range, we recommend you to use iron wheels.

* Bracket usage temperature range : -20°C~135°C

If you want to use the brackets at out of the above temperature range, please consult with us.



















RoHS Compliant







UKAI casters in this English catalog follow RoHS Directive (Restriction of Hazardous Substances).

<Substances restricted by RoHS Directive and their maximum allowable concentrations>

Material	Maximum Allowable Concentration
Lead : Pb	0.1% (1000ppm)
Mercury : Hg	0.1% (1000ppm)
Cadmium: Cd	0.01% (100ppm)
Hexavalent Chromium: Cr ⁶⁺	0.1% (1000ppm)
PBBs	0.1% (1000ppm)
PBDEs	0.1% (1000ppm)

Caster Selection





















	Swivel	Rigid	Swivel with Stopper	Rigid with Stopper	Adjuster
Medium Weight	J Type	K Type	JB Type	KBZ Type	
	 P.15	 P.21	 P.27	 P.33	
Stainless Steel	JA Type	KA Type	JAB Type	KABZ Type	
	 P.39	 P.45	 P.51	 P.57	
Small Type	JM Type	KH Type			AD Type
	 P.63	 P.65			 P.64
Heavy Duty	JM Type	KH Type	JMB Type		
	 P.67	 P.69	 P.71		
Super Heavy Duty	JH Type		JHB Type		
	 P.73		 P.75		
Towing	JHW Type	KHW/KW Type			
	 P.77	 P.78			

	Swivel	Rigid	Swivel with Stopper
Medium Weight	HJ Type  P.99	HK Type  P.100	HJS Type  P.101
	PCJC Type  P.104	PCKE Type  P.105	PCKC Type  P.106











	Swivel	Rigid	Swivel with Stopper
Pneumatic Rubber / Airless Wheel	HLJ/HFJF Type  P.111	HLK/HFKF Type  P.113	HLJB/HFJBF Type  P.115

	Swivel			Adjuster
Low Height	T Type  P.79	TN Type (Dust-Proof)  P.80	TH Type (Heavy Duty)  P.81	AE Type  P.82

Wheel Selection

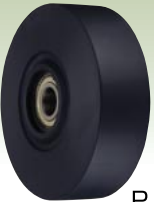
Medium Weight	Wheel Materials					
	Rubber		Urethane Rubber		Nylon	
Steel Rim	S Type	SR Type (Red Rubber)	SUI Type	SUIE Type (Anti-Static)		
	 P.83	 P.83	 P.85	 P.85	Build-to-order manufacturing	
	SH Type (High-Rebound)	CR Type (Heat-resistance)				
	 P.84	 P.84				
	Radial Bearing	SV Type	SHV Type (High-Rebound)			
		 P.90	 P.90			
Nylon Rim	PN Type		PNU Type	PB Type		
	 P.86		 P.87	 P.89		
	Stainless Steel Bearing	PND Type		PNUD Type	PBD Type	
 P.86			 P.87	 P.89		
Spindle Sleeve ⊗	PNA Type		PNUA Type	P Type		
 P.88		 P.88		 P.90		
	Pneumatic Rubber / Airless Wheel	Rubber Wheel Steel Rim	Silent Running Wheel	Steel		
	HL/HF Type	H Type	PC Type	F Type	Spindle Sleeve ⊗	
	 P.116	 P.102	 P.108	 P.98	 P.98	

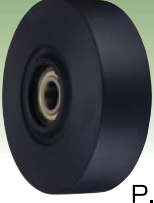
* The wheel with a spindle sleeve may cause trudge, noise, etc. when heavily loaded. When heavily loaded, we recommend you to use a wheel including bearings.

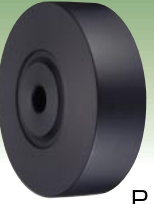
Heavy Duty	Wheel Materials				
	Rubber	Urethane Rubber	Nylon	MC Nylon	
Steel Rim	RG-200	RF Type			
	 P.91	 P.92			
Aluminium Rim	RG-100~150 Type	R Type		RR-130~200 Type	
	 P.91	 P.92		 P.93	
Nylon Rim			RGN Type		
			 P.91		
MC Nylon Rim				RR-50~100 Type	
				 P.93	
				UWB Type	UWBS Type
				 P.94	 P.97
Stainless Steel Bearing				UWBD Type	UWBSD Type
				 P.95	 P.97
Spindle Sleeve ※				UWA Type	
				 P.96	

* The wheel with a spindle sleeve may cause trudge, noise, etc. when heavily loaded. When heavily loaded, we recommend you to use a wheel including bearings.



UKAI CASTERS

Castors

Medium Weight Caster Series







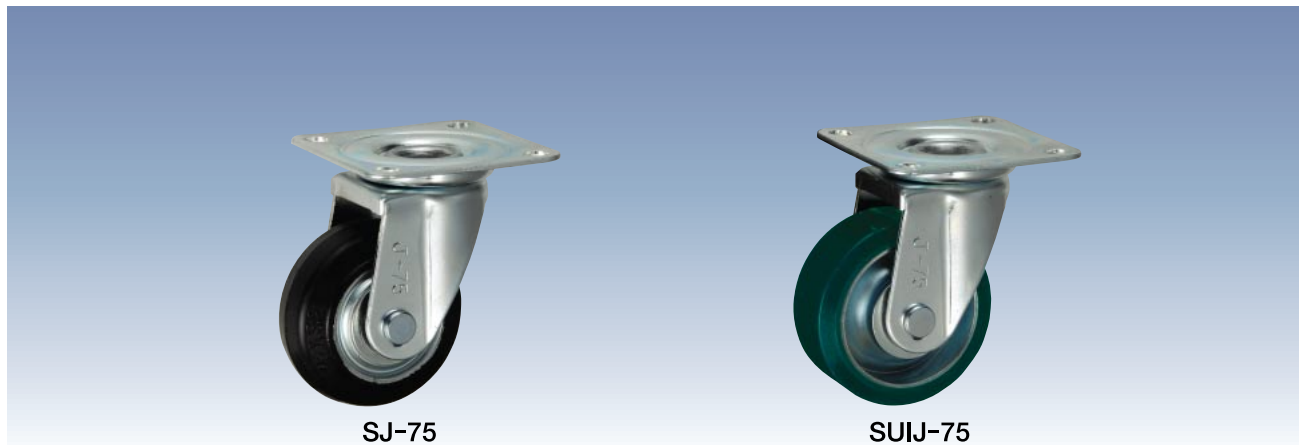

J Type

Size: 75mm

Medium Weight Swivel Bracket



Unit: mm

Size 	Model Number	Wheel	Bearing	Load Capacity		Tire Width R 	Shaft Diameter D 	Overall Height H1 	Plate Size F1/F2 	Mounting Hole Spacing P1/P2 	Plate Hole d 	Offset E 	Weight (g) 
				(daN)	(kgf)								
75	■ Steel Rim · Rubber Wheel												
	SJ-75	Rubber	B/B	80	81.6	32	10	101	82/82	63/63	9.5	22	570
	SRJ-75	Red Rubber	B/B	60	61.2								570
	CRJ-75	Heat-resistance	B/B	80	81.6								590
	■ Steel Rim · Urethane Rubber Wheel												
	SUIJ-75	Urethane	B/B	120	122.4	32	10	101	82/82	63/63	9.5	22	650
	SUIEJ-75	Anti-Static	B/B										650
	■ Nylon Rim · Rubber Wheel												
	PNJ-75	Rubber	B/B	70	71.4	32	10	101	82/82	63/63	9.5	22	550
	PNDJ-75	Rubber	SUS										550
	PNAJ-75	Rubber											510
	■ Nylon Rim · Urethane Rubber Wheel												
	PNUJ-75	Urethane	B/B	100	102.0	32	10	101	82/82	63/63	9.5	22	540
	PNUDJ-75	Urethane	SUS										540
	PNUAJ-75	Urethane		70	71.4								490
	■ Nylon												
	PJ-75	Nylon		100	102.0	32	10	101	82/82	63/63	9.5	22	460
	PBJ-75	Nylon	B/B	120	122.4								520
	PBDJ-75	Nylon	SUS										520
	■ Monomer Cast Nylon												
UWBJ-75	MC Nylon	B/B	120	122.4	24	10	101	82/82	63/63	9.5	22	560	
UWBDJ-75	MC Nylon	SUS										560	
UWAJ-75	MC Nylon											520	
UWBSJ-75	MC Nylon	B/B										540	
UWBSDJ-75	MC Nylon	SUS			26							540	

Bearing: No mark -- Spindle sleeve, B/B -- Steel bearing, SUS -- Stainless steel bearing

 Build-to-order manufacturing

J Type

Size: 100mm

Medium Weight Swivel Bracket

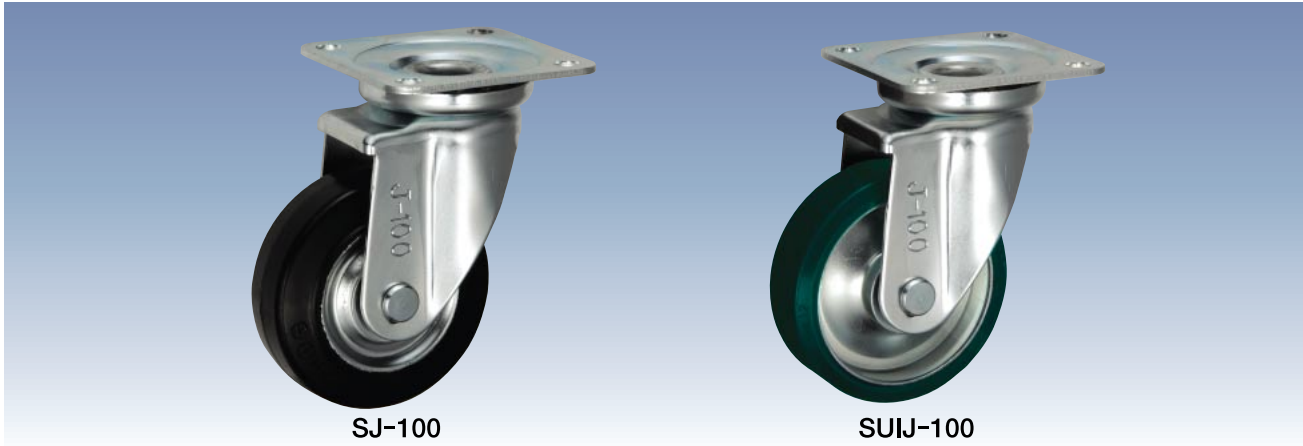

SJ-100

SUIJ-100

Medium Weight Caster Series

Unit: mm

Size 	Model Number	Wheel	Bearing	Load Capacity		Tire Width R	Shaft Diameter D	Overall Height H1	Plate Size F1/F2	Mounting Hole Spacing P1/P2	Plate Hole d	Offset E	Weight (g)	
				(daN)	(kgf)									
100	■Steel Rim·Rubber Wheel													
	SJ-100	Rubber	B/B	130	132.6	35	12	144	95/95	71/71	11	35	1,100	
	SRJ-100	Red Rubber	B/B	100	102.0								1,100	
	CRJ-100	Heat-resistance	B/B	130	132.6								1,130	
	■Steel Rim·Urethane Rubber Wheel													
	SUIJ-100	Urethane	B/B	180	183.6	32	12	144	95/95	71/71	11	35	1,170	
	SUIEJ-100	Anti-Static	B/B										1,170	
	■Nylon Rim·Rubber Wheel													
	PNJ-100	Rubber	B/B	100	102.0	32	12	144	95/95	71/71	11	35	1,000	
	PNDJ-100	Rubber	SUS										1,000	
	PNAJ-100	Rubber											940	
	■Nylon Rim·Urethane Rubber Wheel													
	PNUJ-100	Urethane	B/B	150	153.0	32	12	144	95/95	71/71	11	35	980	
	PNUDJ-100	Urethane	SUS										980	
	PNUAJ-100	Urethane		100	102.0								920	
	■Nylon													
	PJ-100	Nylon		120	122.4	35	12	144	95/95	71/71	11	35	900	
	PBJ-100	Nylon	B/B	180	183.6								960	
	PBDJ-100	Nylon	SUS										960	
	■Monomer Cast Nylon													
UWBJ-100	MC Nylon	B/B	180	183.6	29	12	144	95/95	71/71	11	35	1,110		
UWBDJ-100	MC Nylon	SUS										1,110		
UWAJ-100	MC Nylon											1,060		
UWBSJ-100	MC Nylon	B/B										1,060		
UWBSDJ-100	MC Nylon	SUS			30							1,060		

Bearing: No mark -- Spindle sleeve, B/B -- Steel bearing, SUS -- Stainless steel bearing

 Build-to-order manufacturing

Medium Weight Caster Series







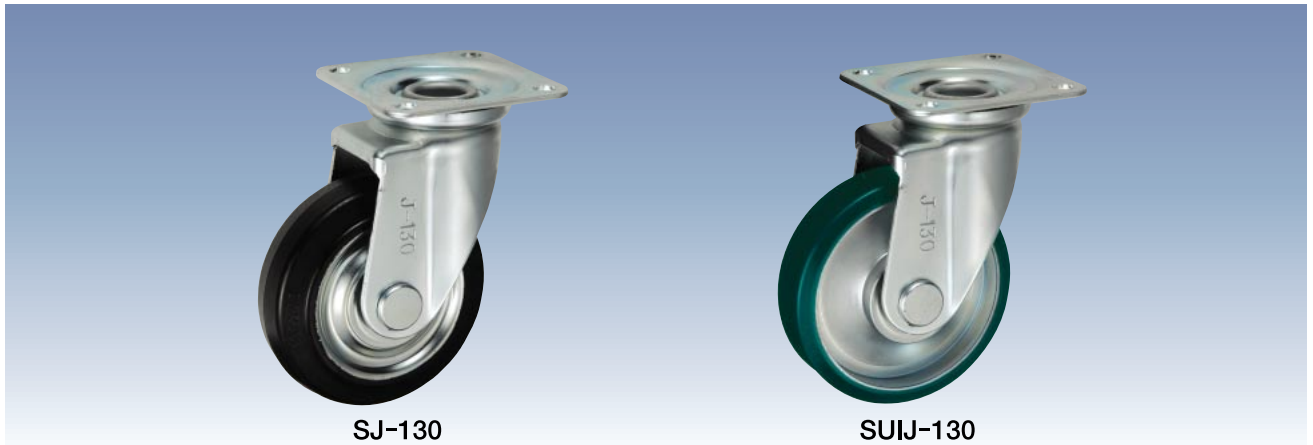

J Type

Size: 130mm

Medium Weight Swivel Bracket



Unit: mm

Size 	Model Number	Wheel	Bearing	Load Capacity		Tire Width R 	Shaft Diameter D 	Overall Height H1 	Plate Size F1/F2 	Mounting Hole Spacing P1/P2 	Plate Hole d 	Offset E 	Weight (g) 
				(daN)	(kgf)								
130	■ Steel Rim · Rubber Wheel												
	SJ-130	Rubber	B/B	180	183.6	42	20	177	108/108	80/80	11	40	1,870
	SRJ-130	Red Rubber	B/B	140	142.8								1,870
	CRJ-130	Heat-resistance	B/B	180	183.6								1,900
	■ Steel Rim · Urethane Rubber Wheel												
	SUIJ-130	Urethane	B/B	250	255.0	35	20	177	108/108	80/80	11	40	2,000
	SUIEJ-130	Anti-Static	B/B										2,000
	■ Nylon Rim · Rubber Wheel												
	PNJ-130	Rubber	B/B	145	147.9	38	20	177	108/108	80/80	11	40	1,670
	PNDJ-130	Rubber	SUS										1,670
	PNAJ-130	Rubber											120
	■ Nylon Rim · Urethane Rubber Wheel												
	PNUJ-130	Urethane	B/B	200	204.0	35	20	177	108/108	80/80	11	40	1,610
	PNUDJ-130	Urethane	SUS										1,610
	PNUAJ-130	Urethane		120	122.4								1,420
	■ Nylon												
	PJ-130	Nylon		150	153.0	42	20	177	108/108	80/80	11	40	1,410
	PBJ-130	Nylon	B/B	250	255.0								1,610
	PBDJ-130	Nylon	SUS										1,610
	■ Monomer Cast Nylon												
	UWBJ-130	MC Nylon	B/B	250	255.0	36	20	177	108/108	80/80	11	40	1,890
UWBDJ-130	MC Nylon	SUS	1,890										
UWAJ-130	MC Nylon		1,740										
UWBSJ-130	MC Nylon	B/B	1,630										
UWBSDJ-130	MC Nylon	SUS	30			1,630							

Bearing: No mark -- Spindle sleeve, B/B -- Steel bearing, SUS -- Stainless steel bearing

 Build-to-order manufacturing

J Type

Size: 150mm

Medium Weight Swivel Bracket

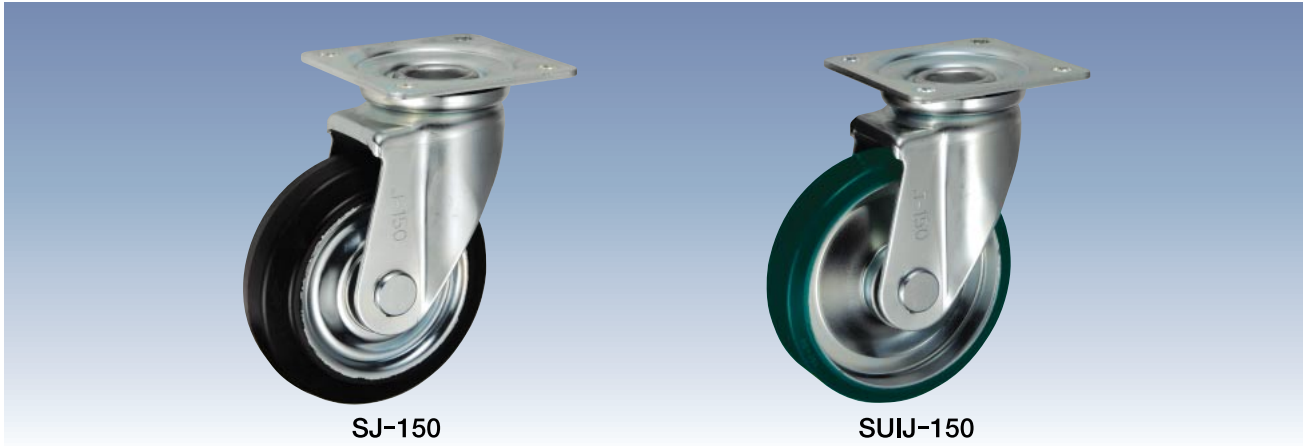

SJ-150

SUIJ-150

Medium Weight Caster Series

Unit: mm

Size 	Model Number	Wheel	Bearing	Load Capacity		Tire Width R	Shaft Diameter D	Overall Height H1	Plate Size F1/F2	Mounting Hole Spacing P1/P2	Plate Hole d	Offset E	Weight (g)	
				(daN)	(kgf)									
150	■Steel Rim·Rubber Wheel													
	SJ-150	Rubber	B/B	200	204.0	45	20	198	120/120	90/90	11	45	2,510	
	SRJ-150	Red Rubber	B/B	160	163.2								2,510	
	CRJ-150	Heat-resistance	B/B	200	204.0								2,550	
	■Steel Rim·Urethane Rubber Wheel													
	SUIJ-150	Urethane	B/B	300	306.0	38	20	198	120/120	90/90	11	45	2,700	
	SUIEJ-150	Anti-Static	B/B										2,700	
	■Nylon Rim·Rubber Wheel													
	PNJ-150	Rubber	B/B	175	178.5	38	20	198	120/120	90/90	11	45	2,220	
	PNDJ-150	Rubber	SUS										2,220	
	PNAJ-150	Rubber											140	142.8
	■Nylon Rim·Urethane Rubber Wheel													
	PNUJ-150	Urethane	B/B	250	255.0	38	20	198	120/120	90/90	11	45	2,180	
	PNUDJ-150	Urethane	SUS										2,180	
	PNUAJ-150	Urethane											150	153.0
	■Nylon													
	PJ-150	Nylon		180	183.6	45	20	198	120/120	90/90	11	45	1,960	
	PBJ-150	Nylon	B/B	300	306.0								2,200	
	PBDJ-150	Nylon	SUS										2,200	
	■Monomer Cast Nylon													
UWBJ-150	MC Nylon	B/B	300	306.0	40	20	198	120/120	90/90	11	45	2,640		
UWBDJ-150	MC Nylon	SUS										2,640		
UWAJ-150	MC Nylon											2,490		
UWBSJ-150	MC Nylon	B/B										2,240		
UWBSDJ-150	MC Nylon	SUS			30							2,240		

Bearing: No mark -- Spindle sleeve, B/B -- Steel bearing, SUS -- Stainless steel bearing

Build-to-order manufacturing

Medium Weight Caster Series

J Type





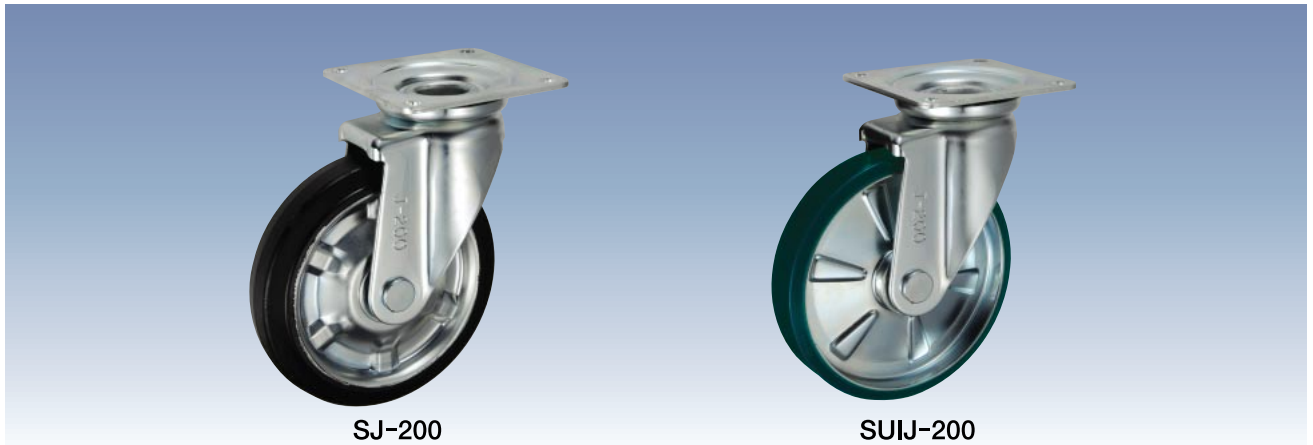



Size: 200mm

Medium Weight Swivel Bracket



SJ-200

SUIJ-200

Size 	Model Number	Wheel	Bearing	Load Capacity		Tire Width R 	Shaft Diameter D 	Overall Height H1 	Plate Size F1/F2 	Mounting Hole Spacing P1/P2 	Plate Hole d 	Offset E 	Weight (g) 	
				(daN)	(kgf)									
200	■Steel Rim·Rubber Wheel													
	SJ-200	Rubber	B/B	250	255.0	45	20	250	140/140	112/112	11	58	4,030	
	SRJ-200	Red Rubber	B/B	200	204.0								4,030	
	SHJ-200	High-Rebound	B/B	250	255.0								4,030	
	CRJ-200	Heat-resistance	B/B										4,110	
	■Steel Rim·Urethane Rubber Wheel													
	SUIJ-200	Urethane	B/B	400	408.0	42	20	250	140/140	112/112	11	58	4,200	
	SUIEJ-200	Anti-Static	B/B										4,200	
	■Nylon Rim·Rubber Wheel													
	PNJ-200	Rubber	B/B	220	224.4	42	20	250	140/140	112/112	11	58	3,380	
	PNDJ-200	Rubber	SUS										3,380	
	PNAJ-200	Rubber											160	163.2
	■Nylon Rim·Urethane Rubber Wheel													
	PNUJ-200	Urethane	B/B	350	357.0	42	20	250	140/140	112/112	11	58	3,250	
	PNUDJ-200	Urethane	SUS										3,250	
	PNUAJ-200	Urethane											250	255.0
	■Nylon													
	PJ-200	Nylon		250	255.0	45	20	250	140/140	112/112	11	58	3,100	
	PBJ-200	Nylon	B/B	400	408.0								3,310	
	PBDJ-200	Nylon	SUS										3,310	
■Monomer Cast Nylon														
UWBJ-200	MC Nylon	B/B	420	428.4	42	20	250	140/140	112/112	11	58	4,260		
UWBDJ-200	MC Nylon	SUS										4,260		
UWAJ-200	MC Nylon											4,110		
UWBSJ-200	MC Nylon	B/B										3,720		
UWBSDJ-200	MC Nylon	SUS			34							3,720		

Unit: mm

Bearing: No mark -- Spindle sleeve, B/B -- Steel bearing, SUS -- Stainless steel bearing

 Build-to-order manufacturing

J Type

Size: 250mm~300mm

Medium Weight Swivel Bracket

Medium Weight Caster Series

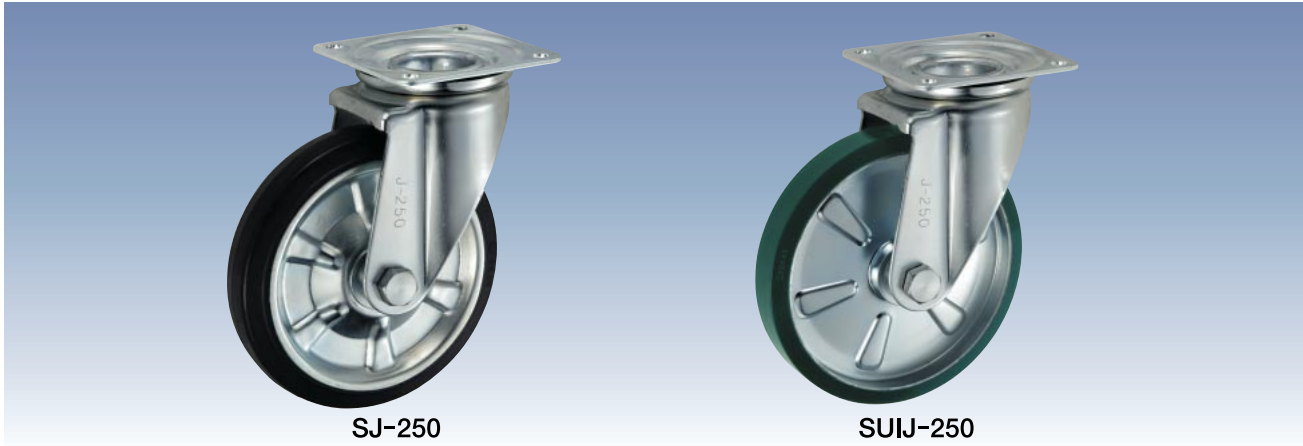

SJ-250

SUIJ-250

Unit: mm

Size 	Model Number	Wheel	Bearing	Load Capacity		Tire Width R	Shaft Diameter D	Overall Height H1	Plate Size F1/F2	Mounting Hole Spacing P1/P2	Plate Hole d	Offset E	Weight (g)
				(daN)	(kgf)								
250	■ Steel Rim · Rubber Wheel												
	SJ-250	Rubber	B/B	330	336.6	50	25	305	160/160	125/125	14	71	6,080
	SRJ-250	Red Rubber	B/B	260	265.2								6,080
	CRJ-250	Heat-resistance	B/B	330	336.6								6,300
	■ Steel Rim · Urethane Rubber Wheel												
SUIJ-250	Urethane	B/B	500	510.0	45	25	305	160/160	125/125	14	71	6,640	
■ Monomer Cast Nylon													
UWBSJ-250	MC Nylon	B/B	550	561.0	36	25	305	160/160	125/125	14	71	5,800	
300	■ Steel Rim · Rubber Wheel												
	SJ-300	Rubber	B/B	350	357.0	50	25	374	175/175	140/140	14	71	9,290
	■ Steel Rim · Urethane Rubber Wheel												
SUIJ-300	Urethane	B/B	600	612.0	50	25	374	175/175	140/140	14	71	8,960	

Bearing: B/B -- Steel bearing

Build-to-order manufacturing

[Bracket Dimensions]

Unit: mm

Size 	Load Capacity		Bracket Height H	Bracket Width B	Weight (g)
	(daN)	(kgf)			
75	120	122.4	63	40	370
100	180	183.6	94	43	740
130	250	255.0	112	53	1,090
150	300	306.0	123	56	1,550
200	420	428.4	150	56	2,360
250	550	561.0	180	90	3,560
300	600	612.0	224	110	4,520

* The shaft set is included in the bracket.

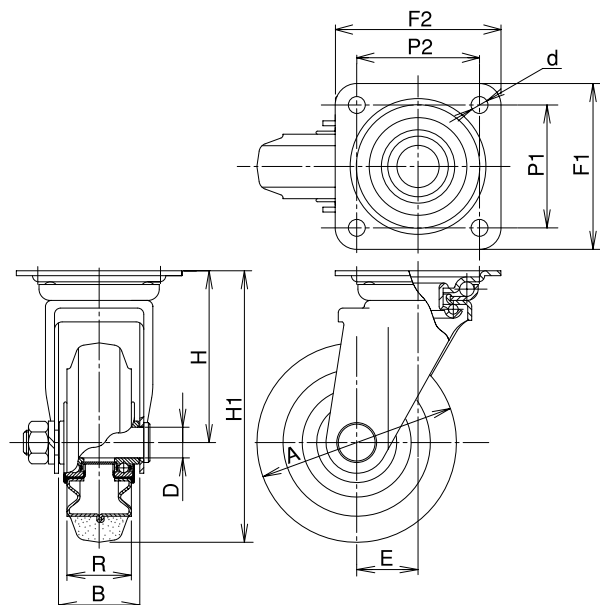

Medium Weight Caster Series

K Type

Size: 75mm

Medium Weight Rigid Bracket



SK-75

SUIK-75

Size 	Model Number	Wheel	Bearing	Load Capacity		Tire Width R	Shaft Diameter D	Overall Height H1	Plate Size F1/F2	Mounting Hole Spacing P1/P2	Plate Hole d	Weight (g)
				(daN)	(kgf)							
75	■ Steel Rim · Rubber Wheel											
	SK-75	Rubber	B/B	80	81.6	32	10	101	91/68	63/40	9.5	430
	SRK-75	Red Rubber	B/B	60	61.2							430
	CRK-75	Heat-resistance	B/B	80	81.6							450
	■ Steel Rim · Urethane Rubber Wheel											
	SUIK-75	Urethane	B/B	120	122.4	32	10	101	91/68	63/40	9.5	510
	SUIEK-75	Anti-Static	B/B									510
	■ Nylon Rim · Rubber Wheel											
	PNK-75	Rubber	B/B	70	71.4	32	10	101	91/68	63/40	9.5	410
	PNDK-75	Rubber	SUS									410
	PNAK-75	Rubber										370
	■ Nylon Rim · Urethane Rubber Wheel											
	PNUK-75	Urethane	B/B	100	102.0	32	10	101	91/68	63/40	9.5	400
	PNUDK-75	Urethane	SUS									400
	PNUAK-75	Urethane		70	71.4							350
	■ Nylon											
	PK-75	Nylon		100	102.0	32	10	101	91/68	63/40	9.5	320
	PBK-75	Nylon	B/B	120	122.4							380
	PBDK-75	Nylon	SUS									380
	■ Monomer Cast Nylon											
	UWBK-75	MC Nylon	B/B	120	122.4	24	10	101	91/68	63/40	9.5	420
UWBDK-75	MC Nylon	SUS	420									
UWAK-75	MC Nylon		380									
UWBSK-75	MC Nylon	B/B	400									
UWBSDK-75	MC Nylon	SUS	26									400

Bearing: No mark -- Spindle sleeve, B/B -- Steel bearing, SUS -- Stainless steel bearing

Build-to-order manufacturing

K Type

Size: 100mm

Medium Weight Rigid Bracket

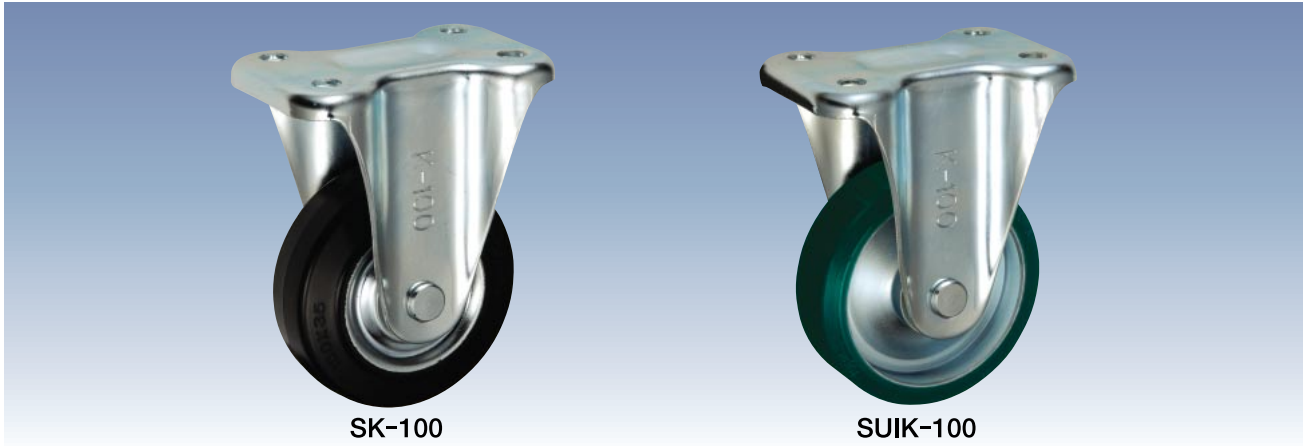

SK-100

SUIK-100

Medium Weight Caster Series

Unit: mm

Size 	Model Number	Wheel	Bearing	Load Capacity		Tire Width R 	Shaft Diameter D 	Overall Height H1 	Plate Size F1/F2 	Mounting Hole Spacing P1/P2 	Plate Hole d 	Weight (g)
				kg (daN)	(kgf)							
100	■ Steel Rim · Rubber Wheel											
	SK-100	Rubber	B/B	130	132.6	35	12	144	115/80	80/45	11	800
	SRK-100	Red Rubber	B/B	100	102.0							800
	CRK-100	Heat-resistance	B/B	130	132.6							830
	■ Steel Rim · Urethane Rubber Wheel											
	SUIK-100	Urethane	B/B	180	183.6	32	12	144	115/80	80/45	11	870
	SUIEK-100	Anti-Static	B/B									870
	■ Nylon Rim · Rubber Wheel											
	PNK-100	Rubber	B/B	100	102.0	32	12	144	115/80	80/45	11	700
	PNDK-100	Rubber	SUS									700
	PNAK-100	Rubber										640
	■ Nylon Rim · Urethane Rubber Wheel											
	PNUK-100	Urethane	B/B	150	153.0	32	12	144	115/80	80/45	11	680
	PNUDK-100	Urethane	SUS									680
	PNUAK-100	Urethane		100	102.0							620
	■ Nylon											
	PK-100	Nylon		120	122.4	35	12	144	115/80	80/45	11	600
	PBK-100	Nylon	B/B	180	183.6							660
	PBDK-100	Nylon	SUS									660
	■ Monomer Cast Nylon											
UWBK-100	MC Nylon	B/B	180	183.6	29	12	144	115/80	80/45	11	810	
UWBDK-100	MC Nylon	SUS									810	
UWAK-100	MC Nylon										760	
UWBSK-100	MC Nylon	B/B			30						760	
UWBSDK-100	MC Nylon	SUS									760	

Bearing: No mark -- Spindle sleeve, B/B -- Steel bearing, SUS -- Stainless steel bearing

Build-to-order manufacturing

Medium Weight Caster Series

K Type

Size: 130mm

Medium Weight Rigid Bracket



SK-130

SUIK-130

Size 	Model Number	Wheel	Bearing	Load Capacity		Tire Width R	Shaft Diameter D	Overall Height H1	Plate Size F1/F2	Mounting Hole Spacing P1/P2 (P2')	Plate Hole d	Weight (g)
				(daN)	(kgf)							
130	■ Steel Rim · Rubber Wheel											
	SK-130	Rubber	B/B	180	183.6	42	20	177	137/93	※100/56 (50)	11	1,580
	SRK-130	Red Rubber	B/B	140	142.8							1,580
	CRK-130	Heat-resistance	B/B	180	183.6							1,610
	■ Steel Rim · Urethane Rubber Wheel											
	SUIK-130	Urethane	B/B	250	255.0	35	20	177	137/93	※100/56 (50)	11	1,710
	SUIEK-130	Anti-Static	B/B									1,710
	■ Nylon Rim · Rubber Wheel											
	PNK-130	Rubber	B/B	145	147.9	38	20	177	137/93	※100/56 (50)	11	1,380
	PNDK-130	Rubber	SUS									1,380
	PNAK-130	Rubber										120
	■ Nylon Rim · Urethane Rubber Wheel											
	PNUK-130	Urethane	B/B	200	204.0	35	20	177	137/93	※100/56 (50)	11	1,320
	PNUDK-130	Urethane	SUS									1,320
	PNUAK-130	Urethane										120
	■ Nylon											
	PK-130	Nylon		250	255.0	42	20	177	137/93	※100/56 (50)	11	1,120
	PBK-130	Nylon	B/B									1,320
	PBDK-130	Nylon	SUS									1,320
	■ Monomer Cast Nylon											
	UWBK-130	MC Nylon	B/B	250	255.0	36	20	177	137/93	※100/56 (50)	11	1,600
UWBDK-130	MC Nylon	SUS	1,600									
UWAK-130	MC Nylon		1,450									
UWBSK-130	MC Nylon	B/B	1,340									
UWBSDK-130	MC Nylon	SUS	30									1,340

Unit: mm

Bearing: No mark -- Spindle sleeve, B/B -- Steel bearing, SUS -- Stainless steel bearing

Build-to-order manufacturing

※Oval-shaped screw holes

K Type

Size: 150mm

Medium Weight Rigid Bracket



SK-150



SUIK-150

Medium Weight Caster Series

Unit: mm

Size 	Model Number	Wheel	Bearing	Load Capacity		Tire Width R 	Shaft Diameter D 	Overall Height H1 	Plate Size F1/F2 	Mounting Hole Spacing P1/P2 (P2') 	Plate Hole d 	Weight (g) 	
				(daN)	(kgf)								
150	■ Steel Rim · Rubber Wheel												
	SK-150	Rubber	B/B	200	204.0	45	20	198	137/93	※100/56 (50)	11	1,960	
	SRK-150	Red Rubber	B/B	160	163.2							1,960	
	CRK-150	Heat-resistance	B/B	200	204.0							2,000	
	■ Steel Rim · Urethane Rubber Wheel												
	SUIK-150	Urethane	B/B	300	306.0	38	20	198	137/93	※100/56 (50)	11	2,150	
	SUIEK-150	Anti-Static	B/B									2,150	
	■ Nylon Rim · Rubber Wheel												
	PNK-150	Rubber	B/B	175	178.5	38	20	198	137/93	※100/56 (50)	11	1,670	
	PNDK-150	Rubber	SUS									1,670	
	PNAK-150	Rubber										140	142.8
	■ Nylon Rim · Urethane Rubber Wheel												
	PNUK-150	Urethane	B/B	250	255.0	38	20	198	137/93	※100/56 (50)	11	1,630	
	PNUDK-150	Urethane	SUS									1,630	
	PNUAK-150	Urethane										150	153.0
	■ Nylon												
	PK-150	Nylon		180	183.6	45	20	198	137/93	※100/56 (50)	11	1,410	
	PBK-150	Nylon	B/B	300	306.0							1,650	
	PBDK-150	Nylon	SUS									1,650	
	■ Monomer Cast Nylon												
UWBK-150	MC Nylon	B/B	300	306.0	40	20	198	137/93	※100/56 (50)	11	2,090		
UWBDK-150	MC Nylon	SUS									2,090		
UWAK-150	MC Nylon										1,940		
UWBSK-150	MC Nylon	B/B									1,690		
UWBSDK-150	MC Nylon	SUS			30						1,690		

※Oval-shaped screw holes

Bearing: No mark -- Spindle sleeve, B/B -- Steel bearing, SUS -- Stainless steel bearing

Build-to-order manufacturing

Medium Weight Caster Series

K Type

Size: 200mm

Medium Weight Rigid Bracket

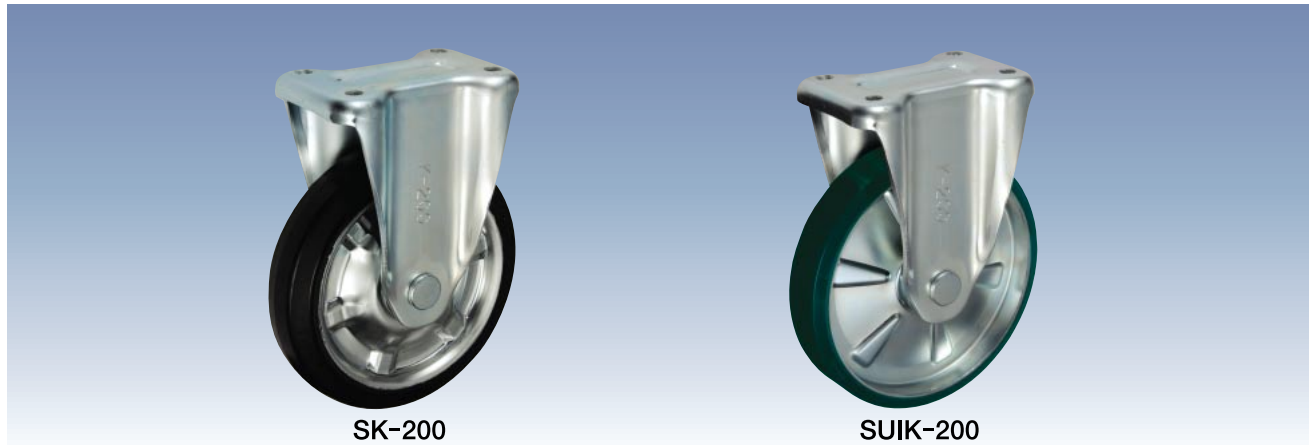

SK-200

SUIK-200

Size 	Model Number	Wheel	Bearing	Load Capacity		Tire Width R	Shaft Diameter D	Overall Height H1	Plate Size F1/F2	Mounting Hole Spacing P1/P2	Plate Hole d	Weight (g)	
				(daN)	(kgf)								
200	■ Steel Rim · Rubber Wheel												
	SK-200	Rubber	B/B	250	255.0	45	20	250	151/102	112/63	11	3,400	
	SRK-200	Red Rubber	B/B	200	204.0							3,400	
	SHK-200	High-Rebound	B/B	250	255.0							3,400	
	CRK-200	Heat-resistance	B/B									3,480	
	■ Steel Rim · Urethane Rubber Wheel												
	SUIK-200	Urethane	B/B	400	408.0	42	20	250	151/102	112/63	11	3,570	
	SUIEK-200	Anti-Static	B/B									3,570	
	■ Nylon Rim · Rubber Wheel												
	PNK-200	Rubber	B/B	220	224.4	42	20	250	151/102	112/63	11	2,750	
	PNDK-200	Rubber	SUS									2,750	
	PNAK-200	Rubber										160	163.2
	■ Nylon Rim · Urethane Rubber Wheel												
	PNUK-200	Urethane	B/B	350	357.0	42	20	250	151/102	112/63	11	2,620	
	PNUDK-200	Urethane	SUS									2,620	
	PNUAK-200	Urethane										250	255.0
	■ Nylon												
	PK-200	Nylon		250	255.0	45	20	250	151/102	112/63	11	2,470	
	PBK-200	Nylon	B/B	400	408.0							2,680	
	PBDK-200	Nylon	SUS									2,680	
■ Monomer Cast Nylon													
UWBK-200	MC Nylon	B/B	420	428.4	42	20	250	151/102	112/63	11	3,630		
UWBDK-200	MC Nylon	SUS									3,630		
UWAK-200	MC Nylon										3,480		
UWBSK-200	MC Nylon	B/B									3,090		
UWBSDK-200	MC Nylon	SUS									34	3,090	

Unit: mm

Bearing: No mark -- Spindle sleeve, B/B -- Steel bearing, SUS -- Stainless steel bearing

Build-to-order manufacturing

K Type

Size: 250mm~300mm

Medium Weight Rigid Bracket

Medium Weight Caster Series

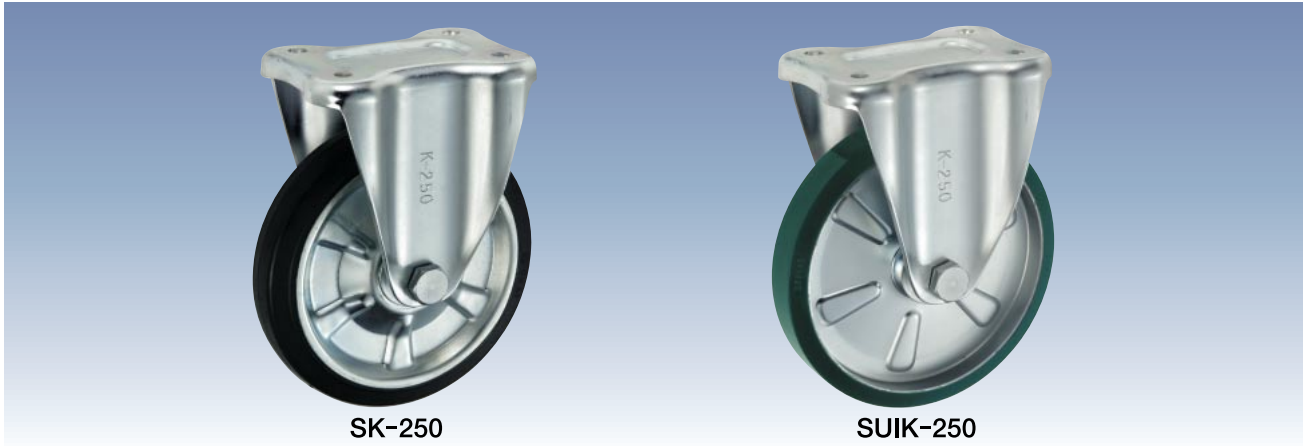

Unit: mm

Size 	Model Number	Wheel	Bearing	Load Capacity		Tire Width R	Shaft Diameter D	Overall Height H1	Plate Size F1/F2	Mounting Hole Spacing P1/P2	Plate Hole d	Weight (g)	
				(daN)	(kgf)								
250	■ Steel Rim - Rubber Wheel												
	SK-250	Rubber	B/B	330	336.6	50	25	305	200/140	140/80	14	5,510	
	SRK-250	Red Rubber	B/B	260	265.2							5,510	
	CRK-250	Heat-resistance	B/B	330	336.6							5,730	
	■ Steel Rim - Urethane Rubber Wheel												
SUIK-250	Urethane	B/B	500	510.0	45	25	305	200/140	140/80	14	6,070		
300	■ Monomer Cast Nylon												
	UWBSK-250	MC Nylon	B/B	550	561.0	36	25	305	200/140	140/80	14	5,230	
	■ Steel Rim - Rubber Wheel												
300	SK-300	Rubber	B/B	350	357.0	50	25	374	220/150	160/90	14	8,830	
	■ Steel Rim - Urethane Rubber Wheel												
SUIK-300	Urethane	B/B	600	612.0	50	25	374	220/150	160/90	14	8,500		

Bearing: B/B -- Steel bearing

Build-to-order manufacturing

[Bracket Dimensions]

Unit: mm

Size 	Load Capacity		Bracket Height H	Bracket Width B	Weight (g)
	(daN)	(kgf)			
75	120	122.4	63	40	230
100	180	183.6	94	43	440
130	250	255.0	112	53	800
150	300	306.0	123	56	1,000
200	420	428.4	150	56	1,730
250	550	561.0	180	90	2,990
300	600	612.0	224	110	4,060

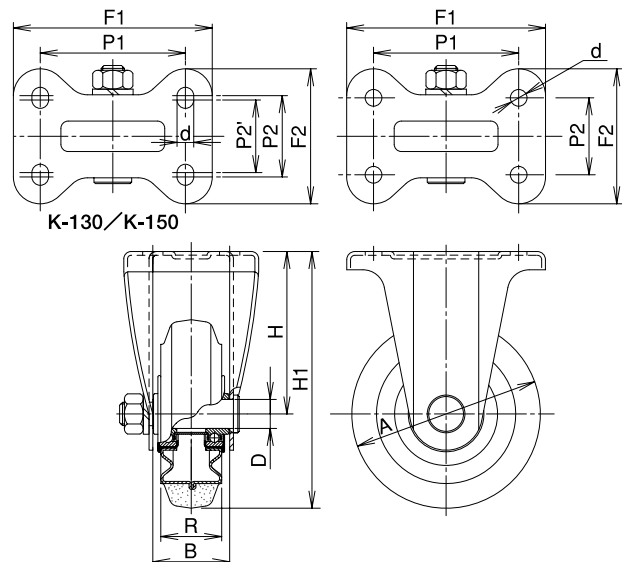

* The shaft set is included in the bracket.

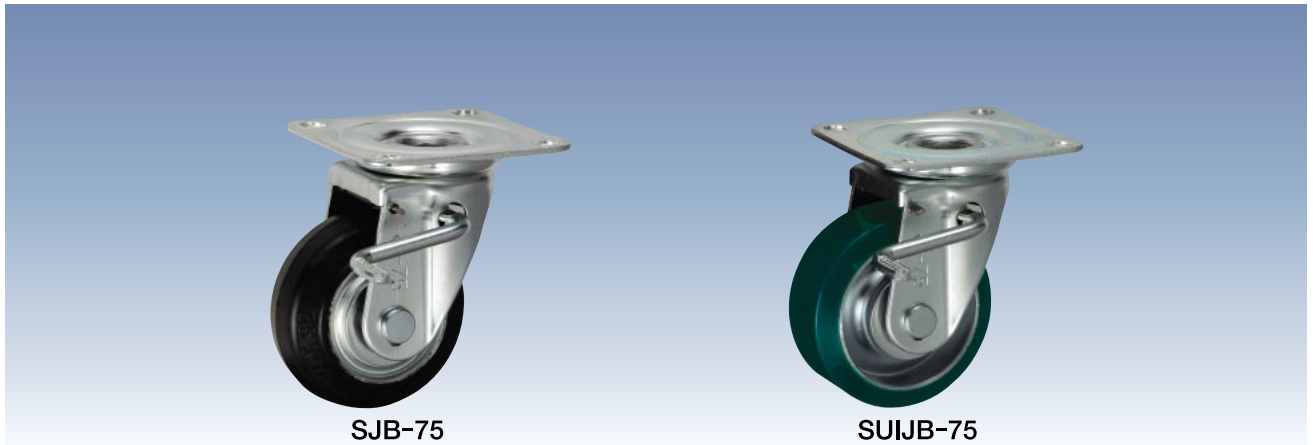

SJB-75

SUIJB-75

Unit: mm

Size 	Model Number	Wheel	Bearing	Load Capacity		Tire Width R	Shaft Diameter D	Overall Height H1	Plate Size F1/F2	Mounting Hole Spacing P1/P2	Plate Hole d	Offset E	Weight (g)	
				(daN)	(kgf)									
75	■ Steel Rim · Rubber Wheel													
	SJB-75	Rubber	B/B	80	81.6	32	10	101	82/82	63/63	9.5	22	620	
	SRJB-75	Red Rubber	B/B	60	61.2								620	
	CRJB-75	Heat-resistance	B/B	80	81.6								640	
	■ Steel Rim · Urethane Rubber Wheel													
	SUIJB-75	Urethane	B/B	120	122.4	32	10	101	82/82	63/63	9.5	22	700	
	SUIEJB-75	Anti-Static	B/B										700	
	■ Nylon Rim · Rubber Wheel													
	PNJB-75	Rubber	B/B	70	71.4	32	10	101	82/82	63/63	9.5	22	600	
	PNDJB-75	Rubber	SUS										600	
	PNAJB-75	Rubber											560	
	■ Nylon Rim · Urethane Rubber Wheel													
	PNUJB-75	Urethane	B/B	100	102.0	32	10	101	82/82	63/63	9.5	22	590	
	PNUDJB-75	Urethane	SUS										590	
	PNUAJB-75	Urethane		70	71.4								540	
	■ Nylon													
	PJB-75	Nylon		100	102.0	32	10	101	82/82	63/63	9.5	22	510	
	PBJB-75	Nylon	B/B	120	122.4								570	
	PBDJB-75	Nylon	SUS										570	
	■ Monomer Cast Nylon													
	UWBJB-75	MC Nylon	B/B	120	122.4	24	10	101	82/82	63/63	9.5	22	610	
UWBDB-75	MC Nylon	SUS	610											
UWAJB-75	MC Nylon		570											
UWBSJB-75	MC Nylon	B/B	590											
UWBSDJB-75	MC Nylon	SUS	26			590								

● The stopper pedal for left foot is not available.

Bearing: No mark -- Spindle sleeve, B/B -- Steel bearing, SUS -- Stainless steel bearing

Build-to-order manufacturing

The JB Type bracket can lock or unlock the wheel and frame at the same time just by stepping the pedal.

JB Type

Size: 100mm

Medium Weight Swivel Bracket with Stopper

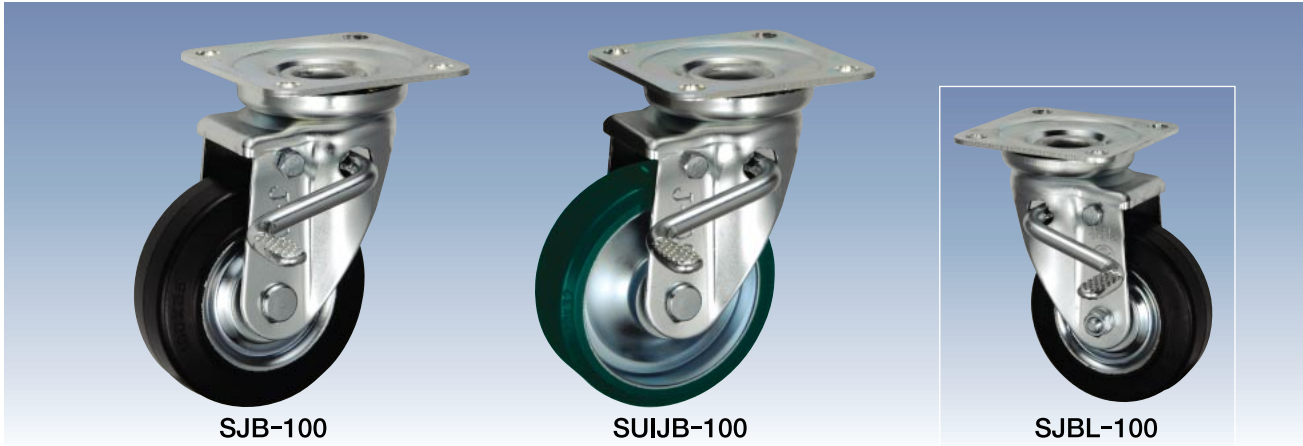

Medium Weight Caster Series

Size 	Model Number	Wheel	Bearing	Load Capacity		Tire Width R	Shaft Diameter D	Overall Height H1	Plate Size F1/F2	Mounting Hole Spacing P1/P2	Plate Hole d	Offset E	Weight (g)	
				(daN)	(kgf)									
100	■ Steel Rim · Rubber Wheel													
	SJB-100	Rubber	B/B	130	132.6	35	12	144	95/95	71/71	11	35	1,230	
	SRJB-100	Red Rubber	B/B	100	102.0								1,230	
	CRJB-100	Heat-resistance	B/B	130	132.6								1,260	
	■ Steel Rim · Urethane Rubber Wheel													
	SUIJB-100	Urethane	B/B	180	183.6	32	12	144	95/95	71/71	11	35	1,300	
	SUIEJB-100	Anti-Static	B/B										1,300	
	■ Nylon Rim · Rubber Wheel													
	PNJB-100	Rubber	B/B	100	102.0	32	12	144	95/95	71/71	11	35	1,130	
	PNDJB-100	Rubber	SUS										1,130	
	PNAJB-100	Rubber											1,070	
	■ Nylon Rim · Urethane Rubber Wheel													
	PNUJB-100	Urethane	B/B	150	153.0	32	12	144	95/95	71/71	11	35	1,110	
	PNUDJB-100	Urethane	SUS										1,110	
	PNUAJB-100	Urethane		100	102.0								1,050	
	■ Nylon													
	PJB-100	Nylon		120	122.4	35	12	144	95/95	71/71	11	35	1,030	
	PBJB-100	Nylon	B/B	180	183.6								1,090	
	PBDJB-100	Nylon	SUS										1,090	
	■ Monomer Cast Nylon													
	UWBJB-100	MC Nylon	B/B	180	183.6	29	12	144	95/95	71/71	11	35	1,240	
UWBDJB-100	MC Nylon	SUS	1,240											
UWAJB-100	MC Nylon		1,190											
UWBSJB-100	MC Nylon	B/B	1,190											
UWBSDJB-100	MC Nylon	SUS	30			1,190								

● The stopper pedal for left foot is available (JB-100 → JBL-100).

Bearing: No mark -- Spindle sleeve, B/B -- Steel bearing, SUS -- Stainless steel bearing

 Build-to-order manufacturing

The JB Type bracket can lock or unlock the wheel and frame at the same time just by stepping the pedal.

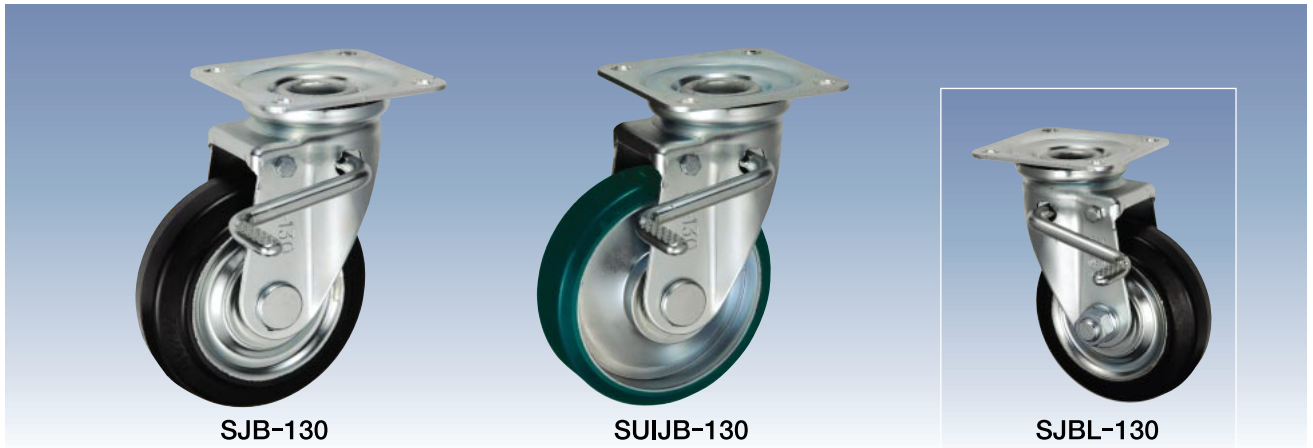

SJB-130

SUIJB-130

SJBL-130

Unit: mm

Size 	Model Number	Wheel	Bearing	Load Capacity		Tire Width R	Shaft Diameter D	Overall Height H1	Plate Size F1/F2	Mounting Hole Spacing P1/P2	Plate Hole d	Offset E	Weight (g)	
				(daN)	(kgf)									
130	■ Steel Rim · Rubber Wheel													
	SJB-130	Rubber	B/B	180	183.6	42	20	177	108/108	80/80	11	40	2,040	
	SRJB-130	Red Rubber	B/B	140	142.8								2,040	
	CRJB-130	Heat-resistance	B/B	180	183.6								2,070	
	■ Steel Rim · Urethane Rubber Wheel													
	SUIJB-130	Urethane	B/B	250	255.0	35	20	177	108/108	80/80	11	40	2,170	
	SUIEJB-130	Anti-Static	B/B										2,170	
	■ Nylon Rim · Rubber Wheel													
	PNJB-130	Rubber	B/B	145	147.9	38	20	177	108/108	80/80	11	40	1,840	
	PNDJB-130	Rubber	SUS										1,840	
	PNAJB-130	Rubber											120	122.4
	■ Nylon Rim · Urethane Rubber Wheel													
	PNUJB-130	Urethane	B/B	200	204.0	35	20	177	108/108	80/80	11	40	1,780	
	PNUDJB-130	Urethane	SUS										1,780	
	PNUAJB-130	Urethane		120	122.4								1,590	
	■ Nylon													
	PJB-130	Nylon		150	153.0	42	20	177	108/108	80/80	11	40	1,580	
	PBJB-130	Nylon	B/B	250	255.0								1,780	
	PBDJB-130	Nylon	SUS										1,780	
	■ Monomer Cast Nylon													
	UWBJB-130	MC Nylon	B/B	250	255.0	36	20	177	108/108	80/80	11	40	2,060	
UWBDJB-130	MC Nylon	SUS	2,060											
UWAJB-130	MC Nylon		1,910											
UWBSJB-130	MC Nylon	B/B	1,800											
UWBSDJB-130	MC Nylon	SUS	30			1,800								

● The stopper pedal for left foot is available (JB-130 → JBL-130).

Bearing: No mark -- Spindle sleeve, B/B -- Steel bearing, SUS -- Stainless steel bearing

Build-to-order manufacturing

The JB Type bracket can lock or unlock the wheel and frame at the same time just by stepping the pedal.

JB Type

Size: 150mm

Medium Weight Swivel Bracket with Stopper

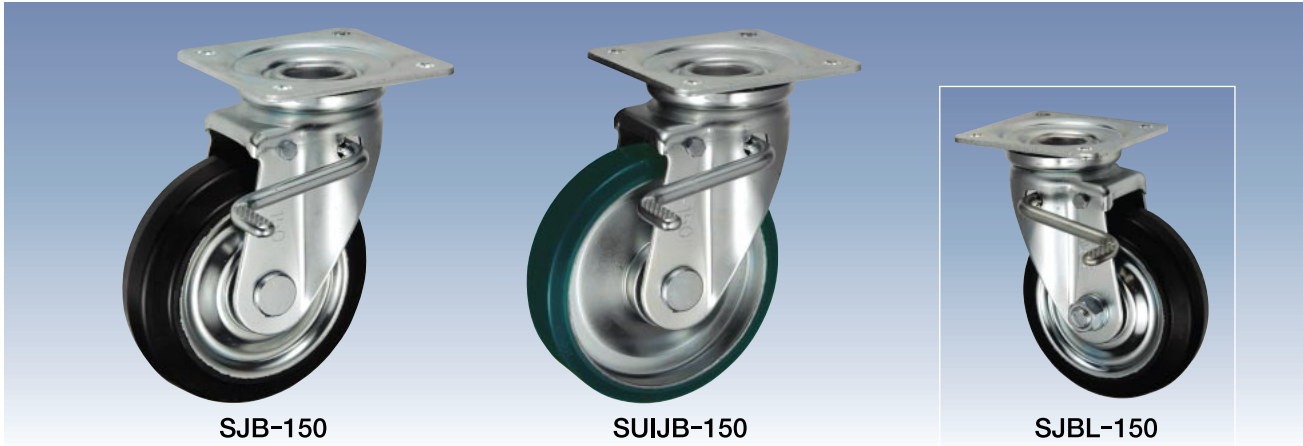

SJB-150

SUIJB-150

SJBL-150

Medium Weight Caster Series

Unit: mm

Size 	Model Number	Wheel	Bearing	Load Capacity		Tire Width R	Shaft Diameter D	Overall Height H1	Plate Size F1/F2	Mounting Hole Spacing P1/P2	Plate Hole d	Offset E	Weight (g)	
				(daN)	(kgf)									
150	■ Steel Rim · Rubber Wheel													
	SJB-150	Rubber	B/B	200	204.0	45	20	198	120/120	90/90	11	45	2,700	
	SRJB-150	Red Rubber	B/B	160	163.2								2,700	
	CRJB-150	Heat-resistance	B/B	200	204.0								2,740	
	■ Steel Rim · Urethane Rubber Wheel													
	SUIJB-150	Urethane	B/B	300	306.0	38	20	198	120/120	90/90	11	45	2,890	
	SUIEJB-150	Anti-Static	B/B										2,890	
	■ Nylon Rim · Rubber Wheel													
	PNJB-150	Rubber	B/B	175	178.5	38	20	198	120/120	90/90	11	45	2,410	
	PNDJB-150	Rubber	SUS										2,410	
	PNAJB-150	Rubber											140	142.8
	■ Nylon Rim · Urethane Rubber Wheel													
	PNUJB-150	Urethane	B/B	250	255.0	38	20	198	120/120	90/90	11	45	2,370	
	PNUDJB-150	Urethane	SUS										2,370	
	PNUAJB-150	Urethane											150	153.0
	■ Nylon													
	PJB-150	Nylon		300	306.0	45	20	198	120/120	90/90	11	45	2,150	
	PBJB-150	Nylon	B/B										2,390	
	PBDJB-150	Nylon	SUS										2,390	
	■ Monomer Cast Nylon													
	UWBJB-150	MC Nylon	B/B	300	306.0	40	20	198	120/120	90/90	11	45	2,830	
UWBDJB-150	MC Nylon	SUS	2,830											
UWAJB-150	MC Nylon		2,680											
UWBSJB-150	MC Nylon	B/B	2,430											
UWBSDJB-150	MC Nylon	SUS	30			2,430								

● The stopper pedal for left foot is available (JB-150 → JBL-150).

Bearing: No mark -- Spindle sleeve, B/B -- Steel bearing, SUS -- Stainless steel bearing

 Build-to-order manufacturing

The JB Type bracket can lock or unlock the wheel and frame at the same time just by stepping the pedal.

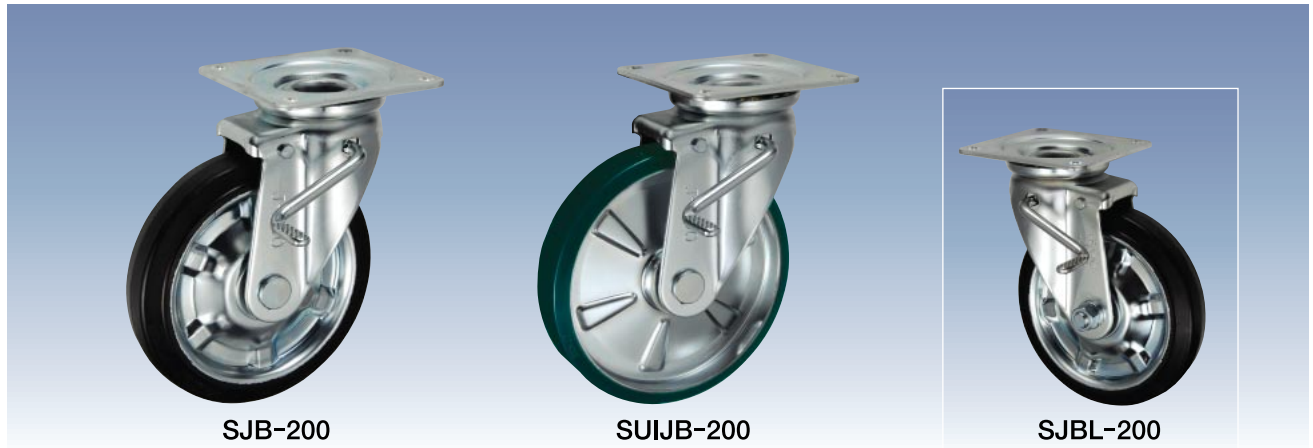

Unit: mm

Size A	Model Number	Wheel	Bearing	Load Capacity		Tire Width R	Shaft Diameter D	Overall Height H1	Plate Size F1/F2	Mounting Hole Spacing P1/P2	Plate Hole d	Offset E	Weight (g)
				(daN)	(kgf)								
200	■ Steel Rim - Rubber Wheel												
	SJB-200	Rubber	B/B	250	255.0	45	20	250	140/140	112/112	11	58	4,240
	SRJB-200	Red Rubber	B/B	200	204.0								4,240
	SHJB-200	High-Rebound	B/B	250	255.0								4,240
	CRJB-200	Heat-resistance	B/B	250	255.0								4,320
	■ Steel Rim - Urethane Rubber Wheel												
	SUIJB-200	Urethane	B/B	400	408.0	42	20	250	140/140	112/112	11	58	4,410
	SUIEJB-200	Anti-Static	B/B										4,410
	■ Nylon Rim - Rubber Wheel												
	PNJB-200	Rubber	B/B	220	224.4	42	20	250	140/140	112/112	11	58	3,590
	PNDJB-200	Rubber	SUS										3,590
	PNAJB-200	Rubber											160
	■ Nylon Rim - Urethane Rubber Wheel												
	PNUJB-200	Urethane	B/B	350	357.0	42	20	250	140/140	112/112	11	58	3,460
	PNUDJB-200	Urethane	SUS										3,460
	PNUAJB-200	Urethane											250
	■ Nylon												
	PJB-200	Nylon		250	255.0	45	20	250	140/140	112/112	11	58	3,310
	PBJB-200	Nylon	B/B	400	408.0								3,520
	PBDJB-200	Nylon	SUS										3,520
■ Monomer Cast Nylon													
UWBJB-200	MC Nylon	B/B	420	428.4	42	20	250	140/140	112/112	11	58	4,470	
UWBDB-200	MC Nylon	SUS										4,470	
UWAJB-200	MC Nylon											4,320	
UWBSJB-200	MC Nylon	B/B										3,930	
UWBSDJB-200	MC Nylon	SUS			34							3,930	

●The stopper pedal for left foot is available (JB-200 → JBL-200).

Bearing: No mark -- Spindle sleeve, B/B -- Steel bearing, SUS -- Stainless steel bearing

Build-to-order manufacturing

The JB Type bracket can lock or unlock the wheel and frame at the same time just by stepping the pedal.



JB Type

Size: 250mm

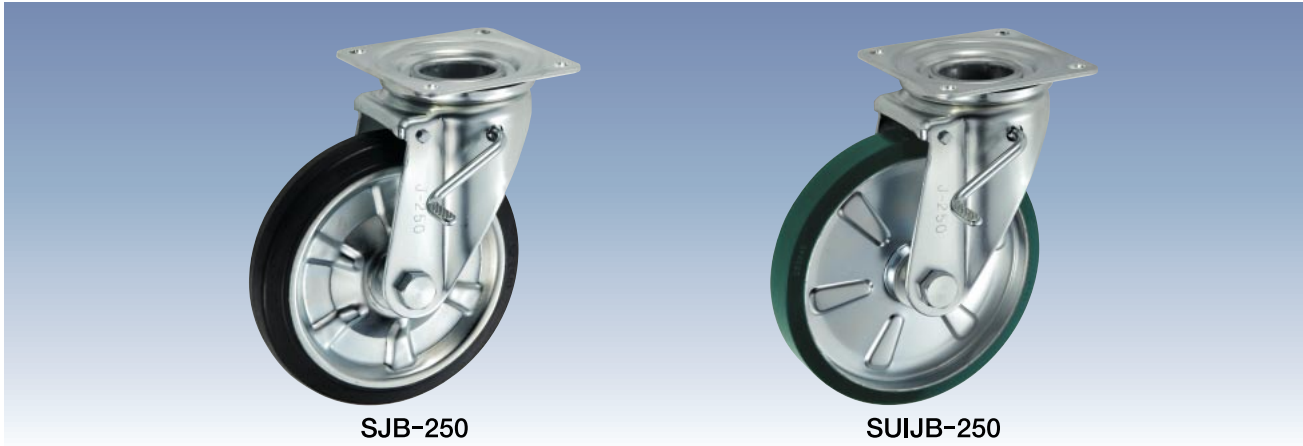
Medium Weight Swivel Bracket with Stopper

SJB-250
SUIJB-250

Medium Weight Caster Series

Size 	Model Number	Wheel	Bearing	Load Capacity		Tire Width R	Shaft Diameter D	Overall Height H1	Plate Size F1/F2	Mounting Hole Spacing P1/P2	Plate Hole d	Offset E	Weight (g)
				(daN)	(kgf)								
250 	■ Steel Rim - Rubber Wheel												
	SJB-250	Rubber	B/B	330	336.6	50	25	305	160/160	125/125	14	71	6,370
	SRJB-250	Red Rubber	B/B	260	265.2								6,370
	CRJB-250	Heat-resistance	B/B	330	336.6								6,590
	■ Steel Rim - Urethane Rubber Wheel												
	SUIJB-250	Urethane	B/B	500	510.0	45	25	305	160/160	125/125	14	71	6,930
■ Monomer Cast Nylon													
UWBSJB-250	MC Nylon	B/B	550	561.0	36	25	305	160/160	125/125	14	71	6,090	

Unit: mm

 ● The stopper pedal for left foot is not available.

Bearing: B/B -- Steel bearing

 Build-to-order manufacturing

The JB Type bracket can lock or unlock the wheel and frame at the same time just by stepping the pedal.

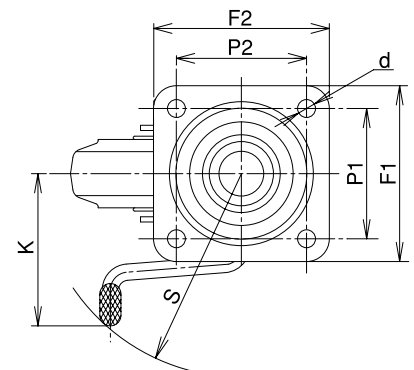

[Bracket Dimensions]

Unit: mm

Size 	Load Capacity		Bracket Height H	Bracket Width B	Weight (g)
	(daN)	(kgf)			
75	120	122.4	63	40	420
100	180	183.6	94	43	870
130	250	255.0	112	53	1,260
150	300	306.0	123	56	1,740
200	420	428.4	150	56	2,570
250	550	561.0	180	90	3,850

[Pedal Dimensions]

Unit: mm

Size 	Pedal Rod K	Radius of Gyration S
75	65	82
100	92	112
130	105	135
150	108	140
200	120	148
250	135	160

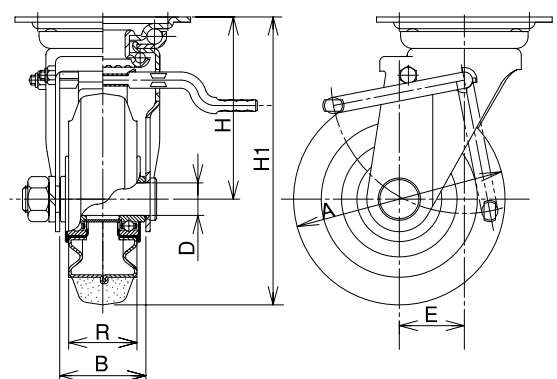

* The shaft set is included in the bracket.

KBZ Type

Size: 75mm

Medium Weight Rigid Bracket with Stopper



SKBZ-75

SUIKBZ-75

SKBZL-75

Unit: mm

Size 	Model Number	Wheel	Bearing	Load Capacity		Tire Width R	Shaft Diameter D	Overall Height H1	Plate Size F1/F2	Mounting Hole Spacing P1/P2	Plate Hole d	Weight (g)	
				(daN)	(kgf)								
75	■ Steel Rim · Rubber Wheel												
	SKBZ-75	Rubber	B/B	80	81.6	32	10	101	91/68	63/40	9.5	480	
	SRKBZ-75	Red Rubber	B/B	60	61.2							480	
	CRKBZ-75	Heat-resistance	B/B	80	81.6							500	
	■ Steel Rim · Urethane Rubber Wheel												
	SUIKBZ-75	Urethane	B/B	120	122.4	32	10	101	91/68	63/40	9.5	560	
	SUIEKBZ-75	Anti-Static	B/B									560	
	■ Nylon Rim · Rubber Wheel												
	PNKBZ-75	Rubber	B/B	70	71.4	32	10	101	91/68	63/40	9.5	460	
	PNDKBZ-75	Rubber	SUS									460	
	PNAKBZ-75	Rubber										420	
	■ Nylon Rim · Urethane Rubber Wheel												
	PNUKBZ-75	Urethane	B/B	100	102.0	32	10	101	91/68	63/40	9.5	450	
	PNUDKBZ-75	Urethane	SUS									450	
	PNUAKBZ-75	Urethane		70	71.4							400	
	■ Nylon												
	PKBZ-75	Nylon		100	102.0	32	10	101	91/68	63/40	9.5	370	
	PBKBZ-75	Nylon	B/B	120	122.4							430	
	PBDKBZ-75	Nylon	SUS									430	
	■ Monomer Cast Nylon												
	UWBKBZ-75	MC Nylon	B/B	120	122.4	24	10	101	91/68	63/40	9.5	470	
UWBDBKBZ-75	MC Nylon	SUS	470										
UWAKBZ-75	MC Nylon		430										
UWBSKBZ-75	MC Nylon	B/B	450										
UWBSDKBZ-75	MC Nylon	SUS	26			450							

● The stopper pedal for left foot is available (KBZ-75 → KBZL-75).

Bearing: No mark -- Spindle sleeve, B/B -- Steel bearing, SUS -- Stainless steel bearing

Build-to-order manufacturing

The stopper of the KBZ Type bracket can lock the wheel to stop the caster.

KBZ Type

Size: 100mm

Medium Weight Rigid Bracket with Stopper



Medium Weight Caster Series

Unit: mm

Size 	Model Number	Wheel	Bearing	Load Capacity		Tire Width R 	Shaft Diameter D 	Overall Height H1 	Plate Size F1/F2 	Mounting Hole Spacing P1/P2 	Plate Hole d 	Weight (g) 	
				(daN)	(kgf)								
100	■ Steel Rim-Rubber Wheel												
	SKBZ-100	Rubber	B/B	130	132.6	35	12	144	115/80	80/45	11	920	
	SRKBZ-100	Red Rubber	B/B	100	102.0							920	
	CRKBZ-100	Heat-resistance	B/B	130	132.6							950	
	■ Steel Rim-Urethane Rubber Wheel												
	SUIKBZ-100	Urethane	B/B	180	183.6	32	12	144	115/80	80/45	11	990	
	SUIEBZ-100	Anti-Static	B/B									990	
	■ Nylon Rim-Rubber Wheel												
	PNKBZ-100	Rubber	B/B	100	102.0	32	12	144	115/80	80/45	11	820	
	PNDKBZ-100	Rubber	SUS									820	
	PNAKBZ-100	Rubber										760	
	■ Nylon Rim-Urethane Rubber Wheel												
	PNUKBZ-100	Urethane	B/B	150	153.0	32	12	144	115/80	80/45	11	800	
	PNUDKBZ-100	Urethane	SUS									800	
	PNUAKBZ-100	Urethane		100	102.0							740	
	■ Nylon												
	PKBZ-100	Nylon		120	122.4	35	12	144	115/80	80/45	11	720	
	PBKBZ-100	Nylon	B/B	180	183.6							780	
	PBDKBZ-100	Nylon	SUS									780	
	■ Monomer Cast Nylon												
UWBKBZ-100	MC Nylon	B/B	180	183.6	29	12	144	115/80	80/45	11	930		
UWBDBZ-100	MC Nylon	SUS									930		
UWAKBZ-100	MC Nylon				880								
UWBSKBZ-100	MC Nylon	B/B			880								
UWBSDKBZ-100	MC Nylon	SUS			30						880		

● The stopper pedal for left foot is available (KBZ-100 → KBZL-100).

Bearing: No mark -- Spindle sleeve, B/B -- Steel bearing, SUS -- Stainless steel bearing

 Build-to-order manufacturing

The stopper of the KBZ Type bracket can lock the wheel to stop the caster.

KBZ Type

Size: 130mm

Medium Weight Rigid Bracket with Stopper



SKBZ-130

SUIKBZ-130

SKBZL-130

Unit: mm

Size 	Model Number	Wheel	Bearing	Load Capacity		Tire Width R	Shaft Diameter D	Overall Height H1	Plate Size F1/F2	Mounting Hole Spacing P1/P2 (P2')	Plate Hole d	Weight (g)	
				(daN)	(kgf)								
130	■ Steel Rim · Rubber Wheel												
	SKBZ-130	Rubber	B/B	180	183.6	42	20	177	137/93	※100/56 (50)	11	1,750	
	SRKBZ-130	Red Rubber	B/B	140	142.8							1,750	
	CRKBZ-130	Heat-resistance	B/B	180	183.6							1,780	
	■ Steel Rim · Urethane Rubber Wheel												
	SUIKBZ-130	Urethane	B/B	250	255.0	35	20	177	137/93	※100/56 (50)	11	1,880	
	SUIEKBZ-130	Anti-Static	B/B									1,880	
	■ Nylon Rim · Rubber Wheel												
	PNKBZ-130	Rubber	B/B	145	147.9	38	20	177	137/93	※100/56 (50)	11	1,550	
	PNDKBZ-130	Rubber	SUS									1,550	
	PNAKBZ-130	Rubber										120	122.4
	■ Nylon Rim · Urethane Rubber Wheel												
	PNUKBZ-130	Urethane	B/B	200	204.0	35	20	177	137/93	※100/56 (50)	11	1,490	
	PNUDKBZ-130	Urethane	SUS									1,490	
	PNUAKBZ-130	Urethane										120	122.4
	■ Nylon												
	PKBZ-130	Nylon		250	255.0	42	20	177	137/93	※100/56 (50)	11	1,290	
	PBKBZ-130	Nylon	B/B									1,490	
	PBDKBZ-130	Nylon	SUS									1,490	
	■ Monomer Cast Nylon												
	UWBKBZ-130	MC Nylon	B/B	250	255.0	36	20	177	137/93	※100/56 (50)	11	1,770	
UWBDBZ-130	MC Nylon	SUS	1,770										
UWAKBZ-130	MC Nylon		1,620										
UWBSKBZ-130	MC Nylon	B/B	1,510										
UWBSDKBZ-130	MC Nylon	SUS	30			1,510							

● The stopper pedal for left foot is available (KBZ-130 → KBZL-130).

※ Oval-shaped screw holes

Bearing: No mark -- Spindle sleeve, B/B -- Steel bearing, SUS -- Stainless steel bearing

Build-to-order manufacturing

The stopper of the KBZ Type bracket can lock the wheel to stop the caster.

KBZ Type

Size: 150mm

Medium Weight Rigid Bracket with Stopper



SKBZ-150

SUIKBZ-150

SKBZL-150

Medium Weight Caster Series

Unit: mm

Size 	Model Number	Wheel	Bearing	Load Capacity		Tire Width R	Shaft Diameter D	Overall Height H1	Plate Size F1/F2	Mounting Hole Spacing P1/P2 (P2')	Plate Hole d	Weight (g)	
				(daN)	(kgf)								
150	■ Steel Rim · Rubber Wheel												
	SKBZ-150	Rubber	B/B	200	204.0	45	20	198	137/93	※100/56 (50)	11	2,140	
	SRKBZ-150	Red Rubber	B/B	160	163.2							2,140	
	CRKBZ-150	Heat-resistance	B/B	200	204.0							2,180	
	■ Steel Rim · Urethane Rubber Wheel												
	SUIKBZ-150	Urethane	B/B	300	306.0	38	20	198	137/93	※100/56 (50)	11	2,330	
	SUIEBZ-150	Anti-Static	B/B									2,330	
	■ Nylon Rim · Rubber Wheel												
	PNKBZ-150	Rubber	B/B	175	178.5	38	20	198	137/93	※100/56 (50)	11	1,850	
	PNDKBZ-150	Rubber	SUS									1,850	
	PNAKBZ-150	Rubber										140	142.8
	■ Nylon Rim · Urethane Rubber Wheel												
	PNUKBZ-150	Urethane	B/B	250	255.0	38	20	198	137/93	※100/56 (50)	11	1,810	
	PNUDKBZ-150	Urethane	SUS									1,810	
	PNUAKBZ-150	Urethane		150	153.0							1,620	
	■ Nylon												
	PKBZ-150	Nylon		180	183.6	45	20	198	137/93	※100/56 (50)	11	1,590	
	PBKBZ-150	Nylon	B/B	300	306.0							1,830	
	PBDKBZ-150	Nylon	SUS									1,830	
	■ Monomer Cast Nylon												
UWBKBZ-150	MC Nylon	B/B	300	306.0	40	20	198	137/93	※100/56 (50)	11	2,270		
UWBDBZ-150	MC Nylon	SUS									2,270		
UWAKBZ-150	MC Nylon										2,120		
UWBSKBZ-150	MC Nylon	B/B									1,870		
UWBSDKBZ-150	MC Nylon	SUS			30						1,870		

● The stopper pedal for left foot is available (KBZ-150 → KBZL-150).

※ Oval-shaped screw holes

Bearing: No mark -- Spindle sleeve, B/B -- Steel bearing, SUS -- Stainless steel bearing

 Build-to-order manufacturing

The stopper of the KBZ Type bracket can lock the wheel to stop the caster.

KBZ Type

Size: 200mm

Medium Weight Rigid Bracket with Stopper





SKBZ-200

SUIKBZ-200

SKBZL-200

Unit: mm

Size 	Model Number	Wheel	Bearing	Load Capacity		Tire Width R	Shaft Diameter D	Overall Height H1	Plate Size F1/F2	Mounting Hole Spacing P1/P2	Plate Hole d	Weight (g)	
				 (daN)	(kgf)								
200	■ Steel Rim · Rubber Wheel												
	SKBZ-200	Rubber	B/B	250	255.0	45	20	250	151/102	112/63	11	3,600	
	SRKBZ-200	Red Rubber	B/B	200	204.0							3,600	
	SHKBZ-200	High-Rebound	B/B	250	255.0							3,600	
	CRKBZ-200	Heat-resistance	B/B									3,680	
	■ Steel Rim · Urethane Rubber Wheel												
	SUIKBZ-200	Urethane	B/B	400	408.0	42	20	250	151/102	112/63	11	3,770	
	SUIEKBZ-200	Anti-Static	B/B									3,770	
	■ Nylon Rim · Rubber Wheel												
	PNKBZ-200	Rubber	B/B	220	224.4	42	20	250	151/102	112/63	11	2,950	
	PNDKBZ-200	Rubber	SUS									2,950	
	PNAKBZ-200	Rubber										160	163.2
	■ Nylon Rim · Urethane Rubber Wheel												
	PNUKBZ-200	Urethane	B/B	350	357.0	42	20	250	151/102	112/63	11	2,820	
	PNUDKBZ-200	Urethane	SUS	250	255.0							2,820	
	PNUAKBZ-200	Urethane										2,650	
	■ Nylon												
	PKBZ-200	Nylon		250	255.0	45	20	250	151/102	112/63	11	2,670	
	PBKBZ-200	Nylon	B/B	400	408.0							2,880	
	PBDKBZ-200	Nylon	SUS									2,880	
■ Monomer Cast Nylon													
UWBKBZ-200	MC Nylon	B/B	420	428.4	42	20	250	151/102	112/63	11	3,830		
UWBDBZ-200	MC Nylon	SUS									3,830		
UWAKBZ-200	MC Nylon										3,680		
UWBSKBZ-200	MC Nylon	B/B									3,290		
UWBSDKBZ-200	MC Nylon	SUS			34	3,290							

●The stopper pedal for left foot is available (KBZ-200 → KBZL-200).

Bearing: No mark -- Spindle sleeve, B/B -- Steel bearing, SUS -- Stainless steel bearing

 Build-to-order manufacturing

The stopper of the KBZ Type bracket can lock the wheel to stop the caster.

KBZ_{Type}



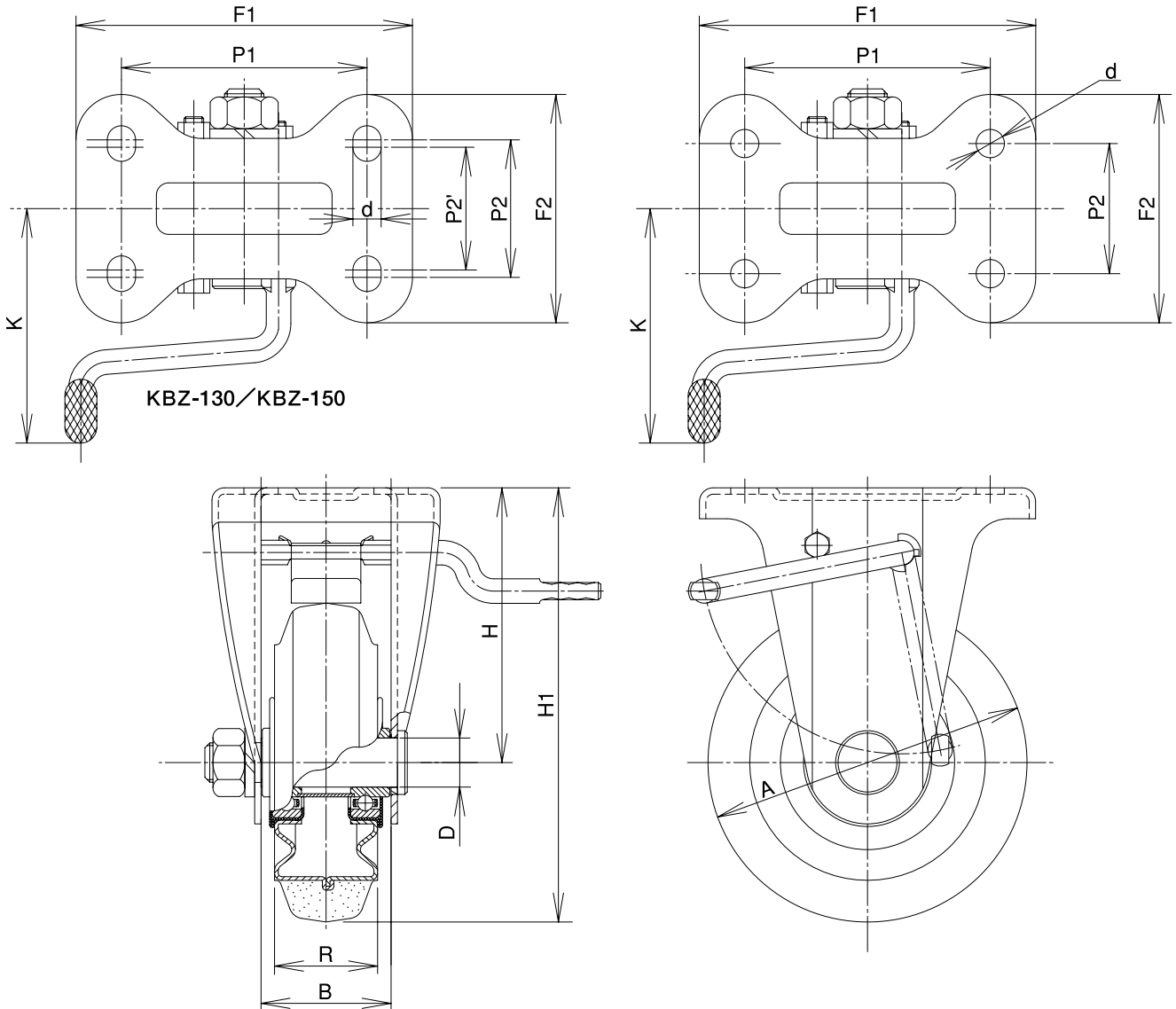

Medium Weight Rigid Bracket with Stopper

Medium Weight Caster Series



[Bracket Dimensions]

Unit: mm

Size 	Load Capacity 		Bracket Height H 	Bracket Width B 	Weight (g) 
	(daN)	(kgf)			
75	120	122.4	63	40	280
100	180	183.6	94	43	560
130	250	255.0	112	53	970
150	300	306.0	123	56	1,180
200	420	428.4	150	56	1,930

[Pedal Dimensions]



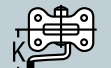



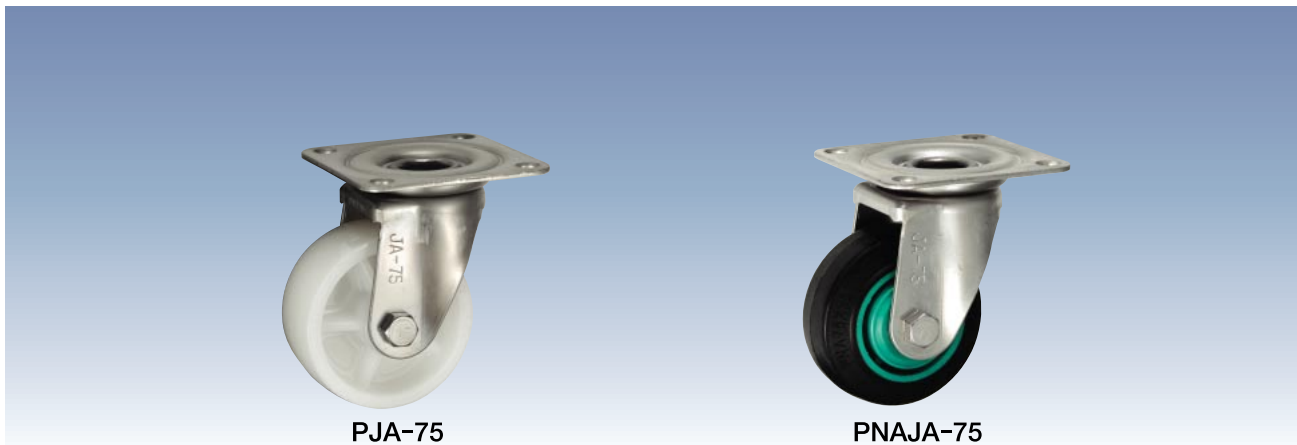

Unit: mm

Size 	Pedal Rod K 
75	72
100	100
130	112
150	112
200	112

* The shaft set is included in the bracket.



Unit: mm

Size 	Model Number	Wheel	Bearing	Load Capacity		Tire Width R 	Shaft Diameter D 	Overall Height H1 	Plate Size F1/F2 	Mounting Hole Spacing P1/P2 	Plate Hole d 	Offset E 	Weight (g) 	
				(daN)	(kgf)									
75	■Nylon													
	PJA-75	Nylon		100	102.0	32	10	101	82/82	63/63	9.5	22	420	
	PBJA-75	Nylon	B/B	120	122.4								480	
	PBDJA-75	Nylon	SUS										480	
	■Nylon Rim·Rubber Wheel													
	PNJA-75	Rubber	B/B	70	71.4	32	10	101	82/82	63/63	9.5	22	510	
	PNDJA-75	Rubber	SUS										510	
	PNAJA-75	Rubber											470	
	■Nylon Rim·Urethane Rubber Wheel													
	PNUJA-75	Urethane	B/B	100	102.0	32	10	101	82/82	63/63	9.5	22	500	
	PNUDJA-75	Urethane	SUS										500	
	PNUAJA-75	Urethane											450	
	■Monomer Cast Nylon													
	UWBJA-75	MC Nylon	B/B	150	153.0	24	10	101	82/82	63/63	9.5	22	520	
	UWBDJA-75	MC Nylon	SUS										520	
	UWAJA-75	MC Nylon											480	
	UWBSJA-75	MC Nylon	B/B			26							500	
	UWBSDJA-75	MC Nylon	SUS										500	
	■Steel Rim·Rubber Wheel <i>Wheel rim is not stainless steel.</i>													
	SJA-75	Rubber	B/B	80	81.6	32	10	101	82/82	63/63	9.5	22	530	
	SRJA-75	Red Rubber	B/B	60	61.2								530	
CRJA-75	Heat-resistance	B/B	80	81.6	550									
■Steel Rim·Urethane Rubber Wheel <i>Wheel rim is not stainless steel.</i>														
SUIJA-75	Urethane	B/B	120	122.4	32	10	101	82/82	63/63	9.5	22	610		
SUIEJA-75	Anti-Static	B/B										610		

Bearing: No mark -- Spindle sleeve, B/B -- Steel bearing, SUS -- Stainless steel bearing

 Build-to-order manufacturing

●The materials of JA Type bracket are all stainless steel (SUS 304 / 18-8 stainless).

JA Type

Size: 100mm

Stainless Steel Swivel Bracket



PJA-100

PNAJA-100

Stainless Steel Caster Series

Unit: mm

Size 	Model Number	Wheel	Bearing	Load Capacity		Tire Width R	Shaft Diameter D	Overall Height H1	Plate Size F1/F2	Mounting Hole Spacing P1/P2	Plate Hole d	Offset E	Weight (g)	
				(daN)	(kgf)									
100	■ Nylon													
	PJA-100	Nylon		120	122.4									870
	PBJA-100	Nylon	B/B	180	183.6	35	12	144	95/95	71/71	11	35	930	
	PBDJA-100	Nylon	SUS										930	
	■ Nylon Rim · Rubber Wheel													
	PNJA-100	Rubber	B/B											970
	PNDJA-100	Rubber	SUS	100	102.0	32	12	144	95/95	71/71	11	35	970	
	PNAJA-100	Rubber												910
	■ Nylon Rim · Urethane Rubber Wheel													
	PNUJA-100	Urethane	B/B											950
	PNUDJA-100	Urethane	SUS	150	153.0	32	12	144	95/95	71/71	11	35	950	
	PNUAJA-100	Urethane		100	102.0									890
	■ Monomer Cast Nylon													
	UWBJA-100	MC Nylon	B/B											1,080
	UWBDA-100	MC Nylon	SUS			29								1,080
	UWAJA-100	MC Nylon		200	204.0		12	144	95/95	71/71	11	35	1,030	
	UWBSJA-100	MC Nylon	B/B			30								1,030
	UWBSDJA-100	MC Nylon	SUS											1,030
	■ Steel Rim · Rubber Wheel Wheel rim is not stainless steel.													
	SJA-100	Rubber	B/B		130	132.6								1,070
SRJA-100	Red Rubber	B/B		100	102.0	35	12	144	95/95	71/71	11	35	1,070	
CRJA-100	Heat-resistance	B/B		130	132.6								1,100	
■ Steel Rim · Urethane Rubber Wheel Wheel rim is not stainless steel.														
SUIJA-100	Urethane	B/B											1,140	
SUIEJA-100	Anti-Static	B/B		180	183.6	32	12	144	95/95	71/71	11	35	1,140	

Bearing: No mark -- Spindle sleeve, B/B -- Steel bearing, SUS -- Stainless steel bearing

Build-to-order manufacturing

● The materials of JA Type bracket are all stainless steel (SUS 304 / 18-8 stainless).

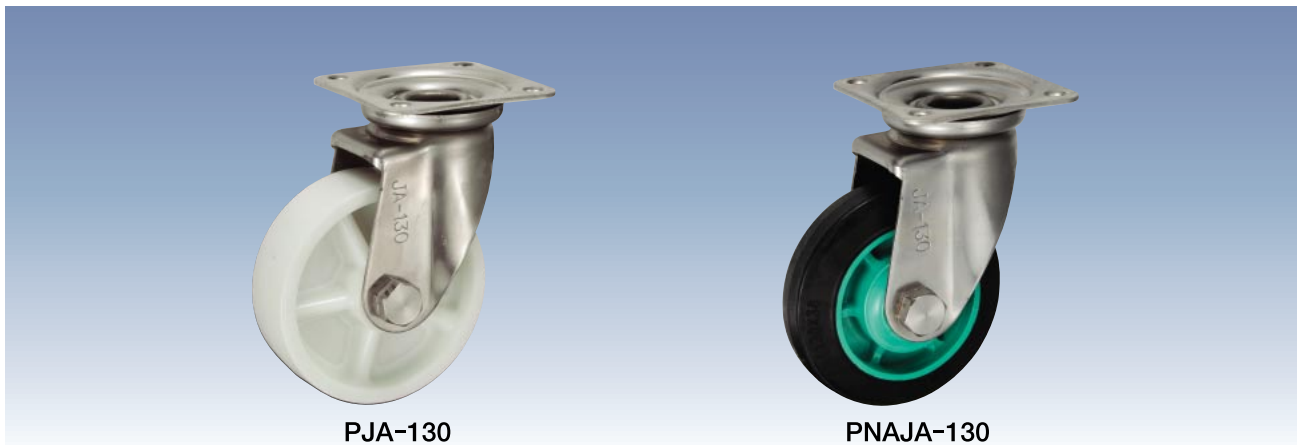

PJA-130

PNAJA-130

Size 	Model Number	Wheel	Bearing	Load Capacity		Tire Width R	Shaft Diameter D	Overall Height H1	Plate Size F1/F2	Mounting Hole Spacing P1/P2	Plate Hole d	Offset E	Weight (g)	
				(daN)	(kgf)									
130	■ Nylon													
	PJA-130	Nylon		150	153.0	42	20	177	108/108	80/80	11	40	1,400	
	PBJA-130	Nylon	B/B	250	255.0								1,600	
	PBDJA-130	Nylon	SUS										1,600	
	■ Nylon Rim · Rubber Wheel													
	PNJA-130	Rubber	B/B	145	147.9	38	20	177	108/108	80/80	11	40	1,660	
	PNDJA-130	Rubber	SUS										1,660	
	PNAJA-130	Rubber											120	122.4
	■ Nylon Rim · Urethane Rubber Wheel													
	PNUJA-130	Urethane	B/B	200	204.0	35	20	177	108/108	80/80	11	40	1,600	
	PNUDJA-130	Urethane	SUS										1,600	
	PNUAJA-130	Urethane											120	122.4
	■ Monomer Cast Nylon													
	UWBJA-130	MC Nylon	B/B	300	306.0	36	20	177	108/108	80/80	11	40	1,880	
	UWBDJA-130	MC Nylon	SUS										1,880	
	UWAJA-130	MC Nylon											1,730	
	UWBSJA-130	MC Nylon	B/B			30							1,620	
	UWBSDJA-130	MC Nylon	SUS										1,620	
	■ Steel Rim · Rubber Wheel Wheel rim is not stainless steel.													
	SJA-130	Rubber	B/B	180	183.6	42	20	177	108/108	80/80	11	40	1,860	
SRJA-130	Red Rubber	B/B	140	142.8	1,860									
CRJA-130	Heat-resistance	B/B	180	183.6	1,890									
■ Steel Rim · Urethane Rubber Wheel Wheel rim is not stainless steel.														
SUIJA-130	Urethane	B/B	250	255.0	35	20	177	108/108	80/80	11	40	1,990		
SUIEJA-130	Anti-Static	B/B										1,990		

Unit: mm

Bearing: No mark -- Spindle sleeve, B/B -- Steel bearing, SUS -- Stainless steel bearing

Build-to-order manufacturing

● The materials of JA Type bracket are all stainless steel (SUS 304 / 18-8 stainless).

JA Type

Size: 150mm

Stainless Steel Swivel Bracket



PJA-150



PNAJA-150

Stainless Steel Caster Series

Unit: mm

Size 	Model Number	Wheel	Bearing	Load Capacity		Tire Width R	Shaft Diameter D	Overall Height H1	Plate Size F1/F2	Mounting Hole Spacing P1/P2	Plate Hole d	Offset E	Weight (g)	
				(daN)	(kgf)									
150	■ Nylon													
	PJA-150	Nylon		180	183.6									1,880
	PBJA-150	Nylon	B/B	300	306.0	45	20	198	120/120	90/90	11	45	2,120	
	PBDJA-150	Nylon	SUS										2,120	
	■ Nylon Rim Rubber Wheel													
	PNJA-150	Rubber	B/B											2,140
	PNDJA-150	Rubber	SUS			38	20	198	120/120	90/90	11	45	2,140	
	PNAJA-150	Rubber		140	142.8									1,980
	■ Nylon Rim Urethane Rubber Wheel													
	PNUJA-150	Urethane	B/B											2,100
	PNUDJA-150	Urethane	SUS	250	255.0	38	20	198	120/120	90/90	11	45	2,100	
	PNUAJA-150	Urethane		150	153.0									1,910
	■ Monomer Cast Nylon													
	UWBJA-150	MC Nylon	B/B											2,560
	UWBDJA-150	MC Nylon	SUS			40								2,560
	UWAJA-150	MC Nylon		350	357.0		20	198	120/120	90/90	11	45	2,410	
	UWBSJA-150	MC Nylon	B/B			30								2,160
	UWBSDJA-150	MC Nylon	SUS											2,160
	■ Steel Rim Rubber Wheel Wheel rim is not stainless steel.													
	SJA-150	Rubber	B/B	200	204.0									2,430
	SRJA-150	Red Rubber	B/B	160	163.2	45	20	198	120/120	90/90	11	45	2,430	
CRJA-150	Heat-resistance	B/B	200	204.0									2,470	
■ Steel Rim Urethane Rubber Wheel Wheel rim is not stainless steel.														
SUIJA-150	Urethane	B/B											2,620	
SUIEJA-150	Anti-Static	B/B	300	306.0	38	20	198	120/120	90/90	11	45	2,620		

Bearing: No mark -- Spindle sleeve, B/B -- Steel bearing, SUS -- Stainless steel bearing









Build-to-order manufacturing

● The materials of JA Type bracket are all stainless steel (SUS 304 / 18-8 stainless).



PJA-200

PNAJA-200

Size 	Model Number	Wheel	Bearing	Load Capacity		Tire Width R 	Shaft Diameter D 	Overall Height H1 	Plate Size F1/F2 	Mounting Hole Spacing P1/P2 	Plate Hole d 	Offset E 	Weight (g) 	
				(daN)	(kgf)									
200	■ Nylon													
	PJA-200	Nylon		250	255.0	45	20	250	140/140	112/112	11	58	2,910	
	PBJA-200	Nylon	B/B	400	408.0								3,120	
	PBDJA-200	Nylon	SUS										3,120	
	■ Nylon Rim · Rubber Wheel													
	PNJA-200	Rubber	B/B	220	224.4	42	20	250	140/140	112/112	11	58	3,190	
	PNDJA-200	Rubber	SUS										3,190	
	PNAJA-200	Rubber											160	163.2
	■ Nylon Rim · Urethane Rubber Wheel													
	PNUJA-200	Urethane	B/B	350	357.0	42	20	250	140/140	112/112	11	58	3,060	
	PNUDJA-200	Urethane	SUS										3,060	
	PNUAJA-200	Urethane											250	255.0
	■ Monomer Cast Nylon													
	UWBJA-200	MC Nylon	B/B	500	510.0	42	20	250	140/140	112/112	11	58	4,070	
	UWBDA-200	MC Nylon	SUS										4,070	
	UWAJA-200	MC Nylon											3,920	
	UWBSJA-200	MC Nylon	B/B										3,530	
	UWBSDJA-200	MC Nylon	SUS			34	3,530							
	■ Steel Rim · Rubber Wheel <i>Wheel rim is not stainless steel.</i>													
	SJA-200	Rubber	B/B	250	255.0	45	20	250	140/140	112/112	11	58	3,840	
SRJA-200	Red Rubber	B/B	200	204.0	3,840									
SHJA-200	High-Rebound	B/B	250	255.0	3,840									
CRJA-200	Heat-resistance	B/B			3,920									
■ Steel Rim · Urethane Rubber Wheel <i>Wheel rim is not stainless steel.</i>														
SUIJA-200	Urethane	B/B	400	408.0	42	20	250	140/140	112/112	11	58	4,010		
SUIEJA-200	Anti-Static	B/B										4,010		

Unit: mm

Bearing: No mark -- Spindle sleeve, B/B -- Steel bearing, SUS -- Stainless steel bearing

 Build-to-order manufacturing

● The materials of JA Type bracket are all stainless steel (SUS 304 / 18-8 stainless).



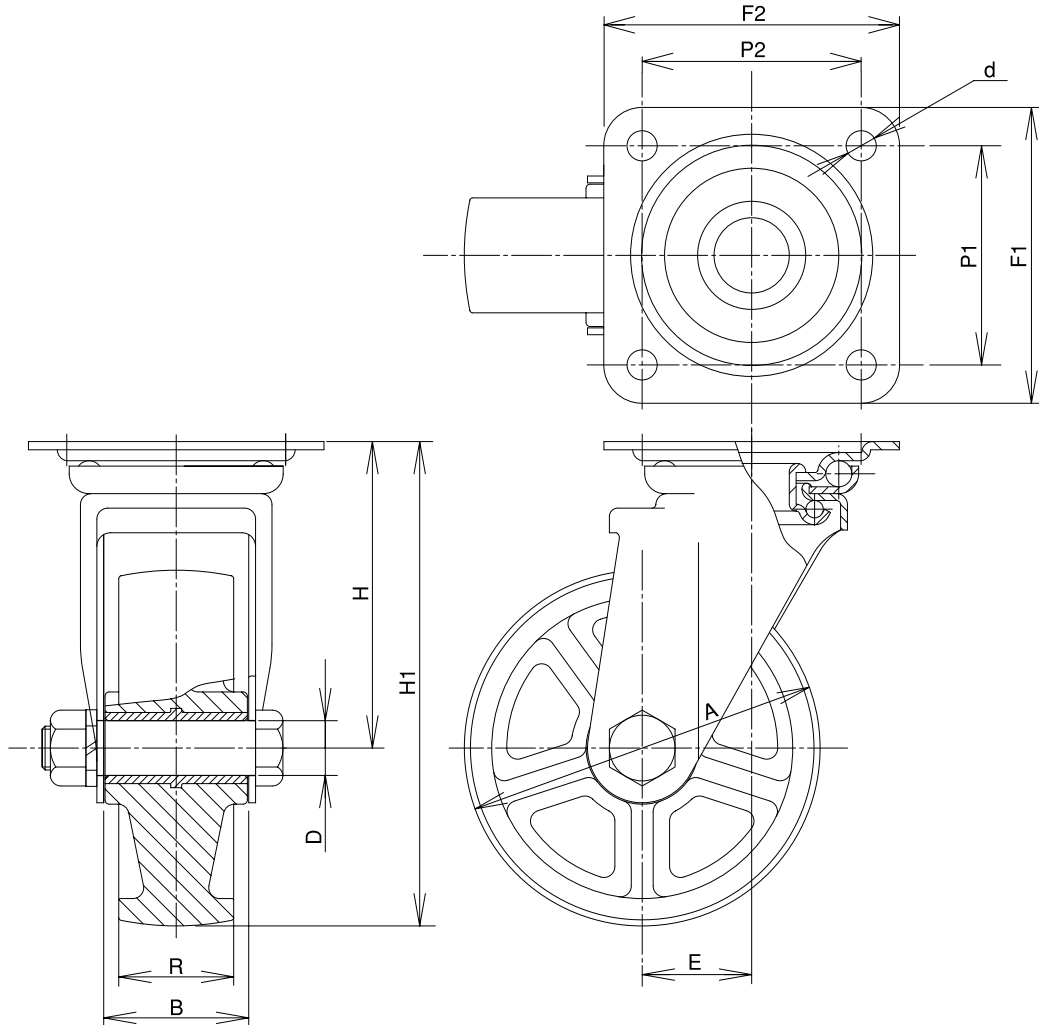

JA Type

Stainless Steel Swivel Bracket



【Bracket Dimensions】

Unit: mm

Size 	Load Capacity 		Bracket Height H 	Bracket Width B 	Weight (g) 
	(daN)	(kgf)			
75	150	153.0	63	40	330
100	200	204.0	94	43	710
130	300	306.0	112	53	1,080
150	350	357.0	123	56	1,470
200	500	510.0	150	56	2,170

* The shaft set is included in the bracket.

Notice

The materials of JA Type bracket are all stainless steel, but the following wheels are not stainless steel. In addition, stainless steel bearings cannot be set.

Please be careful when selecting a caster.

Steel Rim • Rubber Wheel (S, SR, SH, CR Type)

Steel Rim • Urethane Wheel (SUI, SUIE Type)

KA Type

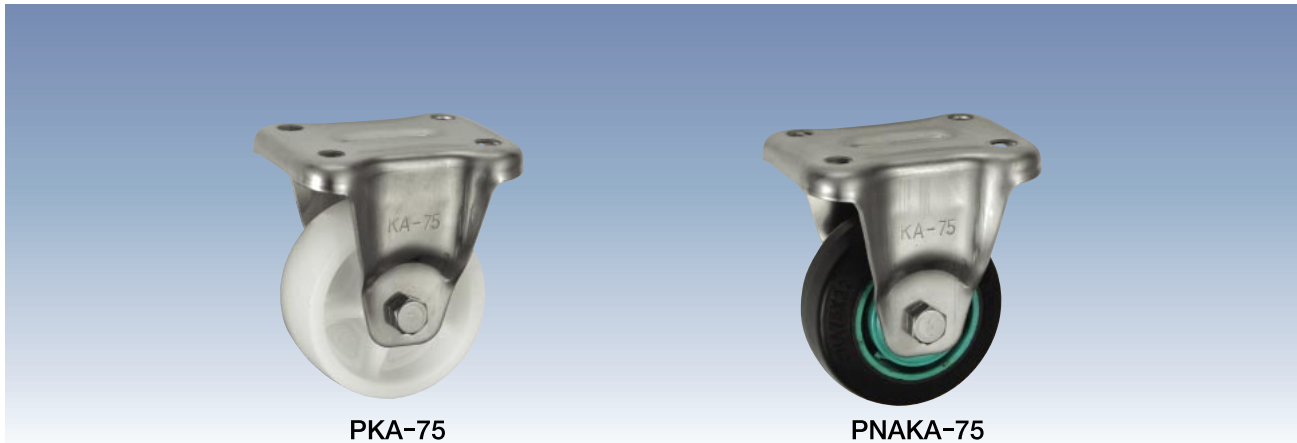

Size: 75mm

Stainless Steel Rigid Bracket



PKA-75

PNAKA-75

Size 	Model Number	Wheel	Bearing	Load Capacity		Tire Width R	Shaft Diameter D	Overall Height H1	Plate Size F1/F2	Mounting Hole Spacing P1/P2	Plate Hole d	Weight (g)
				 (daN)	(kgf)							
75	■ Nylon											
	PKA-75	Nylon		100	102.0	32	10	101	91/68	63/40	9.5	310
	PBKA-75	Nylon	B/B	120	122.4							370
	PBDKA-75	Nylon	SUS									370
	■ Nylon Rim · Rubber Wheel											
	PNKA-75	Rubber	B/B	70	71.4	32	10	101	91/68	63/40	9.5	400
	PNDKA-75	Rubber	SUS									400
	PNAKA-75	Rubber										360
	■ Nylon Rim · Urethane Rubber Wheel											
	PNUKA-75	Urethane	B/B	100	102.0	32	10	101	91/68	63/40	9.5	390
	PNUDKA-75	Urethane	SUS									390
	PNUAKA-75	Urethane										340
	■ Monomer Cast Nylon											
	UWBKA-75	MC Nylon	B/B	150	153.0	24	10	101	91/68	63/40	9.5	410
	UWBDKA-75	MC Nylon	SUS									410
	UWAKA-75	MC Nylon										370
	UWBSKA-75	MC Nylon	B/B			390						
	UWBSDKA-75	MC Nylon	SUS			390						
	■ Steel Rim · Rubber Wheel Wheel rim is not stainless steel.											
	SKA-75	Rubber	B/B	80	81.6	32	10	101	91/68	63/40	9.5	420
	SRKA-75	Red Rubber	B/B	60	61.2							420
CRKA-75	Heat-resistance	B/B	80	81.6	440							
■ Steel Rim · Urethane Rubber Wheel Wheel rim is not stainless steel.												
SUIKA-75	Urethane	B/B	120	122.4	32	10	101	91/68	63/40	9.5	500	
SUIEKA-75	Anti-Static	B/B									500	

Unit: mm

Bearing: No mark -- Spindle sleeve, B/B -- Steel bearing, SUS -- Stainless steel bearing

Build-to-order manufacturing

● The materials of KA Type bracket are all stainless steel (SUS 304 / 18-8 stainless).

KA Type

Size: 100mm



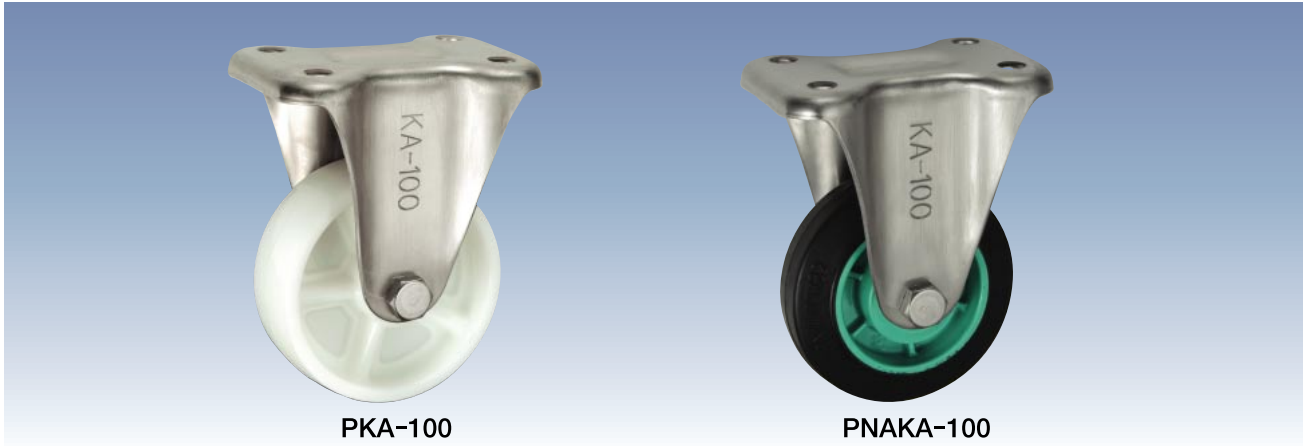





Stainless Steel Rigid Bracket



PKA-100

PNAKA-100

Unit: mm

Size 	Model Number	Wheel	Bearing	Load Capacity 		Tire Width R 	Shaft Diameter D 	Overall Height H1 	Plate Size F1/F2 	Mounting Hole Spacing P1/P2 	Plate Hole d 	Weight (g) 
				(daN)	(kgf)							
100	■Nylon											
	PKA-100	Nylon		120	122.4	35	12	144	115/80	80/45	11	580
	PBKA-100	Nylon	B/B	180	183.6							640
	PBDKA-100	Nylon	SUS									640
	■Nylon Rim·Rubber Wheel											
	PNKA-100	Rubber	B/B	100	102.0	32	12	144	115/80	80/45	11	680
	PNDKA-100	Rubber	SUS									680
	PNAKA-100	Rubber										620
	■Nylon Rim·Urethane Rubber Wheel											
	PNUKA-100	Urethane	B/B	150	153.0	32	12	144	115/80	80/45	11	660
	PNUDKA-100	Urethane	SUS									660
	PNUAKA-100	Urethane										600
	■Monomer Cast Nylon											
	UWBKA-100	MC Nylon	B/B	200	204.0	29	12	144	115/80	80/45	11	790
	UWBKA-100	MC Nylon	SUS									790
	UWAKA-100	MC Nylon										740
	UWBSKA-100	MC Nylon	B/B									740
	UWBSDKA-100	MC Nylon	SUS			30	740					
	■Steel Rim·Rubber Wheel <i>Wheel rim is not stainless steel.</i>											
	SKA-100	Rubber	B/B	130	132.6	35	12	144	115/80	80/45	11	780
	SRKA-100	Red Rubber	B/B	100	102.0							780
CRKA-100	Heat-resistance	B/B	130	132.6	810							
■Steel Rim·Urethane Rubber Wheel <i>Wheel rim is not stainless steel.</i>												
SUIKA-100	Urethane	B/B	180	183.6	32	12	144	115/80	80/45	11	850	
SUIEKA-100	Anti-Static	B/B									850	

Bearing: No mark -- Spindle sleeve, B/B -- Steel bearing, SUS -- Stainless steel bearing

 Build-to-order manufacturing

●The materials of KA Type bracket are all stainless steel (SUS 304 / 18-8 stainless).

KA Type

Size: 130mm

Stainless Steel Rigid Bracket

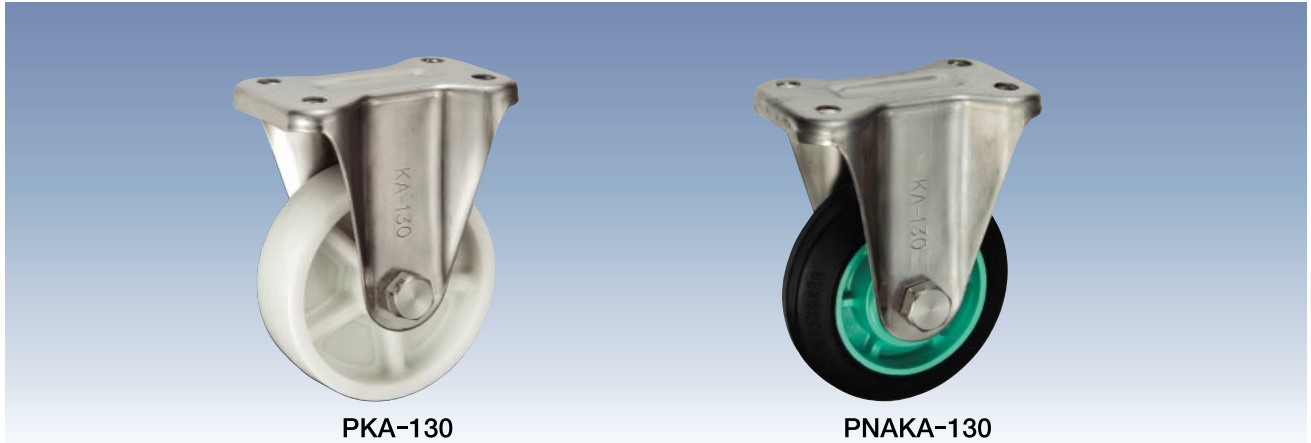

Unit: mm

Size 	Model Number	Wheel	Bearing	Load Capacity		Tire Width R	Shaft Diameter D	Overall Height H1	Plate Size F1/F2	Mounting Hole Spacing P1/P2	Plate Hole d	Weight (g)	
				(daN)	(kgf)								
130	■ Nylon												
	PKA-130	Nylon		150	153.0	42	20	177	137/93	100/56	11	1,130	
	PBKA-130	Nylon	B/B	250	255.0							1,330	
	PBDKA-130	Nylon	SUS									1,330	
	■ Nylon Rim · Rubber Wheel												
	PNKA-130	Rubber	B/B	145	147.9	38	20	177	137/93	100/56	11	1,390	
	PNDKA-130	Rubber	SUS									1,390	
	PNAKA-130	Rubber										1,200	
	■ Nylon Rim · Urethane Rubber Wheel												
	PNUKA-130	Urethane	B/B	200	204.0	35	20	177	137/93	100/56	11	1,330	
	PNUDKA-130	Urethane	SUS									1,330	
	PNUAKA-130	Urethane										1,140	
	■ Monomer Cast Nylon												
	UWBKA-130	MC Nylon	B/B	300	306.0	36	20	177	137/93	100/56	11	1,610	
	UWBDKA-130	MC Nylon	SUS									1,610	
	UWAKA-130	MC Nylon										1,460	
	UWBSKA-130	MC Nylon	B/B									1,350	
	UWBSDKA-130	MC Nylon	SUS			30	1,350						
	■ Steel Rim · Rubber Wheel <i>Wheel rim is not stainless steel.</i>												
	SKA-130	Rubber	B/B	180	183.6	42	20	177	137/93	100/56	11	1,590	
	SRKA-130	Red Rubber	B/B	140	142.8							1,590	
CRKA-130	Heat-resistance	B/B	180	183.6	1,620								
■ Steel Rim · Urethane Rubber Wheel <i>Wheel rim is not stainless steel.</i>													
SUIKA-130	Urethane	B/B	250	255.0	35	20	177	137/93	100/56	11	1,720		
SUIEKA-130	Anti-Static	B/B									1,720		

Bearing: No mark -- Spindle sleeve, B/B -- Steel bearing, SUS -- Stainless steel bearing

 Build-to-order manufacturing

● The materials of KA Type bracket are all stainless steel (SUS 304 / 18-8 stainless).

KA Type

Size: 150mm

Stainless Steel Rigid Bracket



PKA-150

PNAKA-150

Unit: mm

Size 	Model Number	Wheel	Bearing	Load Capacity		Tire Width R 	Shaft Diameter D 	Overall Height H1 	Plate Size F1/F2 	Mounting Hole Spacing P1/P2 	Plate Hole d 	Weight (g) 	
				(daN)	(kgf)								
150	■ Nylon												
	PKA-150	Nylon		180	183.6	45	20	198	137/93	100/56	11	1,370	
	PBKA-150	Nylon	B/B	300	306.0							1,610	
	PBDKA-150	Nylon	SUS									1,610	
	■ Nylon Rim · Rubber Wheel												
	PNKA-150	Rubber	B/B	175	178.5	38	20	198	137/93	100/56	11	1,630	
	PNDKA-150	Rubber	SUS									1,630	
	PNAKA-150	Rubber										140	142.8
	■ Nylon Rim · Urethane Rubber Wheel												
	PNUKA-150	Urethane	B/B	250	255.0	38	20	198	137/93	100/56	11	1,590	
	PNUDKA-150	Urethane	SUS									1,590	
	PNUAKA-150	Urethane										150	153.0
	■ Monomer Cast Nylon												
	UWBKA-150	MC Nylon	B/B	350	357.0	40	20	198	137/93	100/56	11	2,050	
	UWBDKA-150	MC Nylon	SUS									2,050	
	UWAKA-150	MC Nylon										1,900	
	UWBSKA-150	MC Nylon	B/B									1,650	
	UWBSDKA-150	MC Nylon	SUS			30	1,650						
	■ Steel Rim · Rubber Wheel Wheel rim is not stainless steel.												
	SKA-150	Rubber	B/B	200	204.0	45	20	198	137/93	100/56	11	1,920	
	SRKA-150	Red Rubber	B/B	160	163.2							1,920	
CRKA-150	Heat-resistance	B/B	200	204.0	1,960								
■ Steel Rim · Urethane Rubber Wheel Wheel rim is not stainless steel.													
SUIKA-150	Urethane	B/B	300	306.0	38	20	198	137/93	100/56	11	2,110		
SUIEKA-150	Anti-Static	B/B									2,110		

Bearing: No mark -- Spindle sleeve, B/B -- Steel bearing, SUS -- Stainless steel bearing

Build-to-order manufacturing

● The materials of KA Type bracket are all stainless steel (SUS 304 / 18-8 stainless).

KA Type

Size: 200mm

Stainless Steel Rigid Bracket

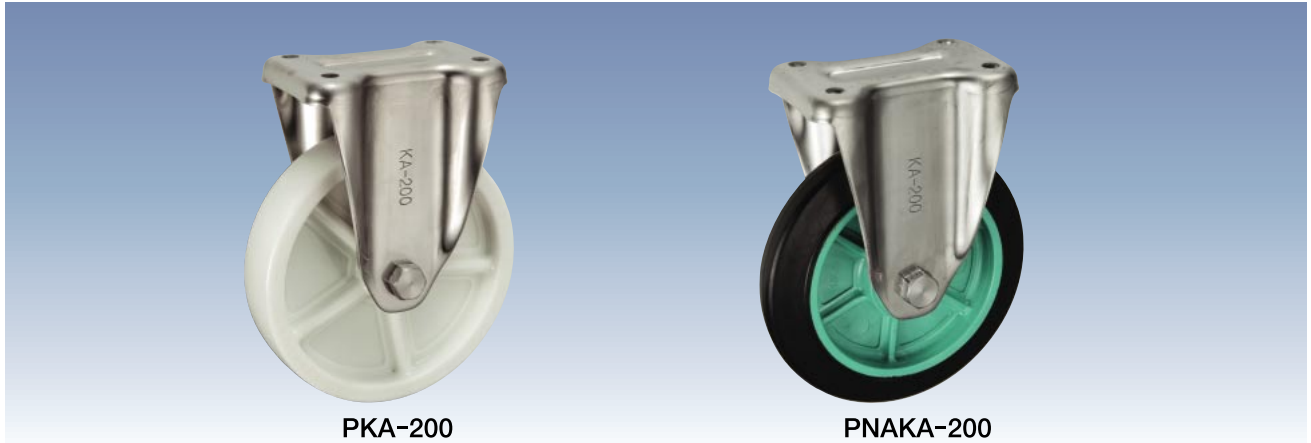

PKA-200

PNAKA-200

Size 	Model Number	Wheel	Bearing	Load Capacity		Tire Width R	Shaft Diameter D	Overall Height H1	Plate Size F1/F2	Mounting Hole Spacing P1/P2	Plate Hole d	Weight (g)
				(daN)	(kgf)							
200	■Nylon											
	PKA-200	Nylon		250	255.0	45	20	250	151/102	112/63	11	2,310
	PBKA-200	Nylon	B/B	400	408.0							2,520
	PBDKA-200	Nylon	SUS									2,520
	■Nylon Rim·Rubber Wheel											
	PNKA-200	Rubber	B/B	220	224.4	42	20	250	151/102	112/63	11	2,590
	PNDKA-200	Rubber	SUS									2,590
	PNAKA-200	Rubber										160
	■Nylon Rim·Urethane Rubber Wheel											
	PNUKA-200	Urethane	B/B	350	357.0	42	20	250	151/102	112/63	11	2,460
	PNUDKA-200	Urethane	SUS									2,460
	PNUAKA-200	Urethane										250
	■Monomer Cast Nylon											
	UWBKA-200	MC Nylon	B/B	500	510.0	42	20	250	151/102	112/63	11	3,470
	UWBKA-200	MC Nylon	SUS									3,470
	UWAKA-200	MC Nylon										3,320
	UWBSKA-200	MC Nylon	B/B			34	2,930					
	UWBSDKA-200	MC Nylon	SUS				2,930					
	■Steel Rim·Rubber Wheel <i>Wheel rim is not stainless steel.</i>											
	SKA-200	Rubber	B/B	250	255.0	45	20	250	151/102	112/63	11	3,240
	SRKA-200	Red Rubber	B/B	200	204.0							3,240
	SHKA-200	High-Rebound	B/B	250	255.0							3,240
CRKA-200	Heat-resistance	B/B	3,320									
■Steel Rim·Urethane Rubber Wheel <i>Wheel rim is not stainless steel.</i>												
SUIKA-200	Urethane	B/B	400	408.0	42	20	250	151/102	112/63	11	3,410	
SUIEKA-200	Anti-Static	B/B									3,410	

Unit: mm

Bearing: No mark -- Spindle sleeve, B/B -- Steel bearing, SUS -- Stainless steel bearing

 Build-to-order manufacturing

●The materials of KA Type bracket are all stainless steel (SUS 304 / 18-8 stainless).

KA Type

Stainless Steel Rigid Bracket

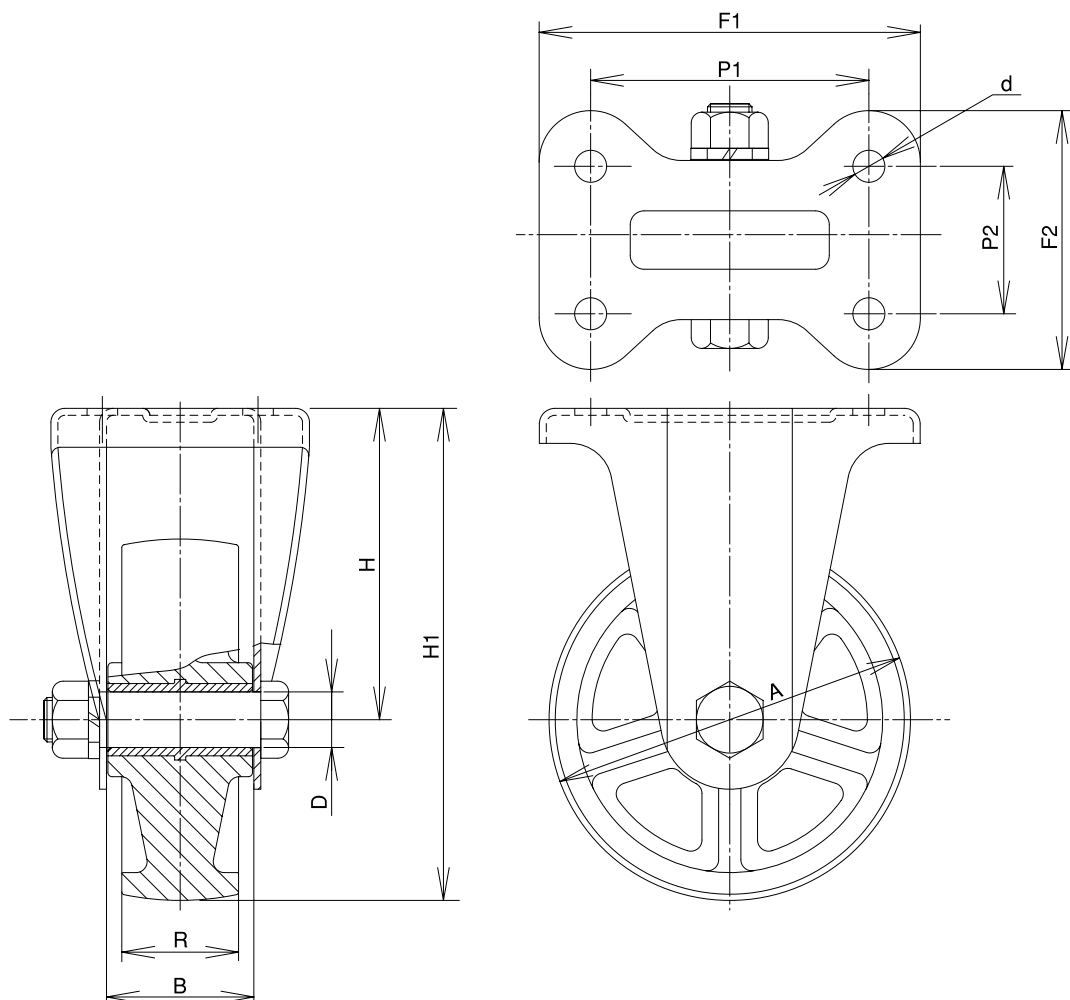

Stainless Steel Caster Series

【Bracket Dimensions】

Unit: mm

Size 	Load Capacity 		Bracket Height H 	Bracket Width B 	Weight (g)
	(daN)	(kgf)			
75	150	153.0	63	40	220
100	200	204.0	94	43	420
130	300	306.0	112	53	810
150	350	357.0	123	56	960
200	500	510.0	150	56	1,570

* The shaft set is included in the bracket.

Notice

The materials of KA Type bracket are all stainless steel, but the following wheels are not stainless steel. In addition, stainless steel bearings cannot be set.

Please be careful when selecting a caster.

Steel Rim • Rubber Wheel (S, SR, SH, CR Type)

Steel Rim • Urethane Wheel (SUI, SUIE Type)

JAB_{Type}

Size: 75mm

Stainless Steel Swivel Bracket with Stopper

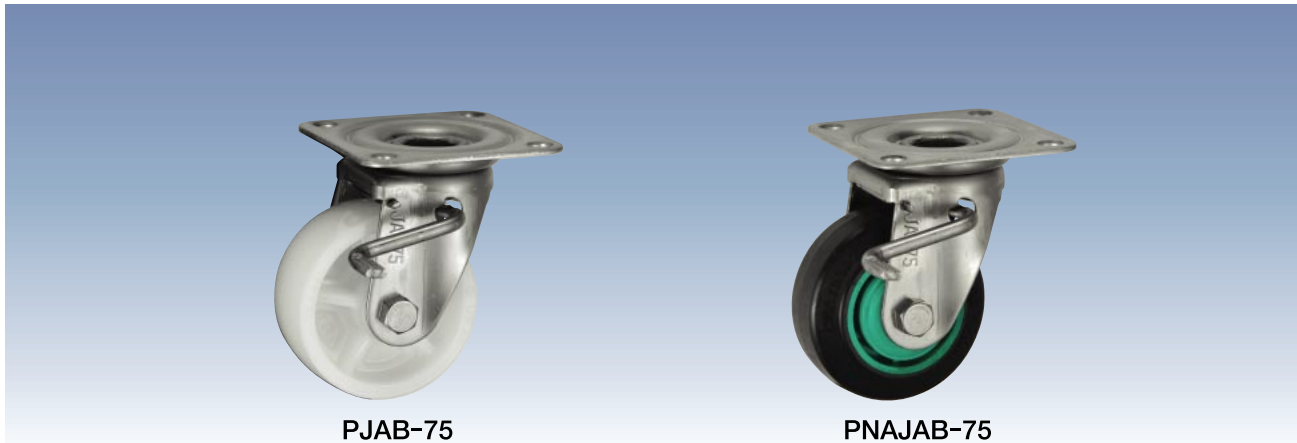

PJAB-75

PNAJAB-75

Size 	Model Number	Wheel	Bearing	Load Capacity		Tire Width R	Shaft Diameter D	Overall Height H1	Plate Size F1/F2	Mounting Hole Spacing P1/P2	Plate Hole d	Offset E	Weight (g)	
				(daN)	(kgf)									
75	■ Nylon													
	PJAB-75	Nylon		100	102.0	32	10	101	82/82	63/63	9.5	22	470	
	PBJAB-75	Nylon	B/B	120	122.4								530	
	PBDJAB-75	Nylon	SUS										530	
	■ Nylon Rim · Rubber Wheel													
	PNJAB-75	Rubber	B/B	70	71.4	32	10	101	82/82	63/63	9.5	22	560	
	PNDJAB-75	Rubber	SUS										560	
	PNAJAB-75	Rubber											520	
	■ Nylon Rim · Urethane Rubber Wheel													
	PNUJAB-75	Urethane	B/B	100	102.0	32	10	101	82/82	63/63	9.5	22	550	
	PNUDJAB-75	Urethane	SUS										550	
	PNUAJAB-75	Urethane											500	
	■ Monomer Cast Nylon													
	UWBJAB-75	MC Nylon	B/B	150	153.0	32	10	101	82/82	63/63	9.5	22	570	
	UWBDJAB-75	MC Nylon	SUS										570	
	UWAJAB-75	MC Nylon											530	
	UWBSJAB-75	MC Nylon	B/B										550	
	UWBSDJAB-75	MC Nylon	SUS										550	
	■ Steel Rim · Rubber Wheel Wheel rim is not stainless steel.													
	SJAB-75	Rubber	B/B	80	81.6	32	10	101	82/82	63/63	9.5	22	580	
	SRJAB-75	Red Rubber	B/B	60	61.2								580	
CRJAB-75	Heat-resistance	B/B	80	81.6	600									
■ Steel Rim · Urethane Rubber Wheel Wheel rim is not stainless steel.														
SUIJAB-75	Urethane	B/B	120	122.4	32	10	101	82/82	63/63	9.5	22	660		
SUIEJAB-75	Anti-Static	B/B										660		

Unit: mm

● The stopper pedal for left foot is not available.

Bearing: No mark -- Spindle sleeve, B/B -- Steel bearing, SUS -- Stainless steel bearing

Build-to-order manufacturing

The JAB Type bracket can lock or unlock the wheel and frame at the same time just by stepping the pedal.

● The materials of JAB Type bracket are all stainless steel (SUS 304 / 18-8 stainless), except plate springs.

For plate springs, SK5 (carbon tool steel) is used for maintaining spring performance, and the surface is plated with nickel chrome.

JAB_{Type}

Size: 100mm

Stainless Steel Swivel Bracket with Stopper



PJAB-100



PNAJAB-100

Stainless Steel Caster Series

Unit: mm

Size 	Model Number	Wheel	Bearing	Load Capacity		Tire Width R	Shaft Diameter D	Overall Height H1	Plate Size F1/F2	Mounting Hole Spacing P1/P2	Plate Hole d	Offset E	Weight (g)	
				(daN)	(kgf)									
100	■Nylon													
	PJAB-100	Nylon		120	122.4									990
	PBJAB-100	Nylon	B/B	180	183.6	35	12	144	95/95	71/71	11	35	1,050	
	PBDJAB-100	Nylon	SUS										1,050	
	■Nylon Rim·Rubber Wheel													
	PNJAB-100	Rubber	B/B											1,090
	PNDJAB-100	Rubber	SUS	100	102.0	32	12	144	95/95	71/71	11	35	1,090	
	PNAJAB-100	Rubber												1,030
	■Nylon Rim·Urethane Rubber Wheel													
	PNUJAB-100	Urethane	B/B	150	153.0	32	12	144	95/95	71/71	11	35	1,070	
	PNUDJAB-100	Urethane	SUS											1,070
	PNUAJAB-100	Urethane		100	102.0									1,010
	■Monomer Cast Nylon													
	UWBJAB-100	MC Nylon	B/B											1,200
	UWBDJAB-100	MC Nylon	SUS			29								1,200
	UWAJAB-100	MC Nylon		200	204.0		12	144	95/95	71/71	11	35		1,150
	UWBSJAB-100	MC Nylon	B/B											1,150
	UWBSDJAB-100	MC Nylon	SUS			30								1,150
	■Steel Rim·Rubber Wheel Wheel rim is not stainless steel.													
	SJAB-100	Rubber	B/B	130	132.6									1,190
	SRJAB-100	Red Rubber	B/B	100	102.0	35	12	144	95/95	71/71	11	35		1,190
CRJAB-100	Heat-resistance	B/B	130	132.6									1,220	
■Steel Rim·Urethane Rubber Wheel Wheel rim is not stainless steel.														
SUIJAB-100	Urethane	B/B											1,260	
SUIEJAB-100	Anti-Static	B/B	180	183.6	32	12	144	95/95	71/71	11	35		1,260	

●The stopper pedal for left foot is not available.

Bearing: No mark -- Spindle sleeve, B/B -- Steel bearing, SUS -- Stainless steel bearing

Build-to-order manufacturing

The JAB Type bracket can lock or unlock the wheel and frame at the same time just by stepping the pedal.

●The materials of JAB Type bracket are all stainless steel (SUS 304 / 18-8 stainless), except plate springs.

For plate springs, SK5 (carbon tool steel) is used for maintaining spring performance, and the surface is plated with nickel chrome.

JAB_{Type}

Size: 130mm

Stainless Steel Swivel Bracket with Stopper

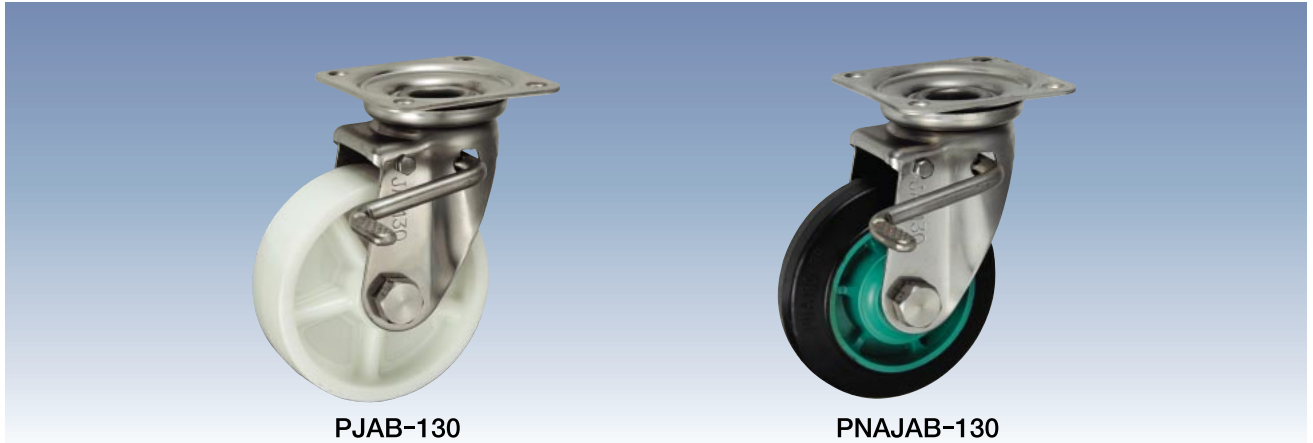

Unit: mm

Size 	Model Number	Wheel	Bearing	Load Capacity		Tire Width R	Shaft Diameter D	Overall Height H1	Plate Size F1/F2	Mounting Hole Spacing P1/P2	Plate Hole d	Offset E	Weight (g)
				(daN)	(kgf)								
130	■ Nylon												
	PJAB-130	Nylon		150	153.0	42	20	177	108/108	80/80	11	40	1,580
	PBJAB-130	Nylon	B/B	250	255.0								1,780
	PBDJAB-130	Nylon	SUS										1,780
	■ Nylon Rim-Rubber Wheel												
	PNJAB-130	Rubber	B/B	145	147.9	38	20	177	108/108	80/80	11	40	1,840
	PNDJAB-130	Rubber	SUS										1,840
	PNAJAB-130	Rubber											120
	■ Nylon Rim-Urethane Rubber Wheel												
	PNUJAB-130	Urethane	B/B	200	204.0	35	20	177	108/108	80/80	11	40	1,780
	PNUDJAB-130	Urethane	SUS										1,780
	PNUAJAB-130	Urethane											120
	■ Monomer Cast Nylon												
	UWBJAB-130	MC Nylon	B/B	300	306.0	36	20	177	108/108	80/80	11	40	2,060
	UWBDJAB-130	MC Nylon	SUS										2,060
	UWAJAB-130	MC Nylon											1,910
	UWBSJAB-130	MC Nylon	B/B			30							1,800
	UWBSDJAB-130	MC Nylon	SUS										1,800
	■ Steel Rim-Rubber Wheel Wheel rim is not stainless steel.												
	SJAB-130	Rubber	B/B	180	183.6	42	20	177	108/108	80/80	11	40	2,040
	SRJAB-130	Red Rubber	B/B	140	142.8								2,040
CRJAB-130	Heat-resistance	B/B	180	183.6	2,070								
■ Steel Rim-Urethane Rubber Wheel Wheel rim is not stainless steel.													
SUIJAB-130	Urethane	B/B	250	255.0	35	20	177	108/108	80/80	11	40	2,170	
SUIEJAB-130	Anti-Static	B/B										2,170	

●The stopper pedal for left foot is not available.

Bearing: No mark -- Spindle sleeve, B/B -- Steel bearing, SUS -- Stainless steel bearing

Build-to-order manufacturing

The JAB Type bracket can lock or unlock the wheel and frame at the same time just by stepping the pedal.

●The materials of JAB Type bracket are all stainless steel (SUS 304 / 18-8 stainless), except plate springs. For plate springs, SK5 (carbon tool steel) is used for maintaining spring performance, and the surface is plated with nickel chrome.

JAB_{Type}

Size: 150mm

Stainless Steel Swivel Bracket with Stopper



PJAB-150



PNAJAB-150

Stainless Steel Caster Series

Unit: mm

Size 	Model Number	Wheel	Bearing	Load Capacity		Tire Width R	Shaft Diameter D	Overall Height H1	Plate Size F1/F2	Mounting Hole Spacing P1/P2	Plate Hole d	Offset E	Weight (g)		
				(daN)	(kgf)										
150	■ Nylon														
	PJAB-150	Nylon		180	183.6									2,080	
	PBJAB-150	Nylon	B/B	300	306.0	45	20	198	120/120	90/90	11	45		2,320	
	PBDJAB-150	Nylon	SUS											2,320	
	■ Nylon Rim · Rubber Wheel														
	PNJAB-150	Rubber	B/B												2,340
	PNDJAB-150	Rubber	SUS			38	20	198	120/120	90/90	11	45		2,340	
	PNAJAB-150	Rubber				140	142.8								2,180
	■ Nylon Rim · Urethane Rubber Wheel														
	PNUJAB-150	Urethane	B/B												2,300
	PNUDJAB-150	Urethane	SUS		250	255.0	38	20	198	120/120	90/90	11	45		2,300
	PNUAJAB-150	Urethane			150	153.0									2,110
	■ Monomer Cast Nylon														
	UWBJAB-150	MC Nylon	B/B												2,760
	UWBDJAB-150	MC Nylon	SUS				40								2,760
	UWAJAB-150	MC Nylon			350	357.0		20	198	120/120	90/90	11	45		2,610
	UWBSJAB-150	MC Nylon	B/B					30							2,360
	UWBSDJAB-150	MC Nylon	SUS												2,360
	■ Steel Rim · Rubber Wheel Wheel rim is not stainless steel.														
	SJAB-150	Rubber	B/B		200	204.0									2,630
SRJAB-150	Red Rubber	B/B		160	163.2	45	20	198	120/120	90/90	11	45		2,630	
CRJAB-150	Heat-resistance	B/B		200	204.0									2,670	
■ Steel Rim · Urethane Rubber Wheel Wheel rim is not stainless steel.															
SUIJAB-150	Urethane	B/B		300	306.0	38	20	198	120/120	90/90	11	45		2,820	
SUIEJAB-150	Anti-Static	B/B												2,820	

● The stopper pedal for left foot is not available.

Bearing: No mark -- Spindle sleeve, B/B -- Steel bearing, SUS -- Stainless steel bearing

Build-to-order manufacturing

The JAB Type bracket can lock or unlock the wheel and frame at the same time just by stepping the pedal.

● The materials of JAB Type bracket are all stainless steel (SUS 304 / 18-8 stainless), except plate springs.

For plate springs, SK5 (carbon tool steel) is used for maintaining spring performance, and the surface is plated with nickel chrome.

JAB_{Type}





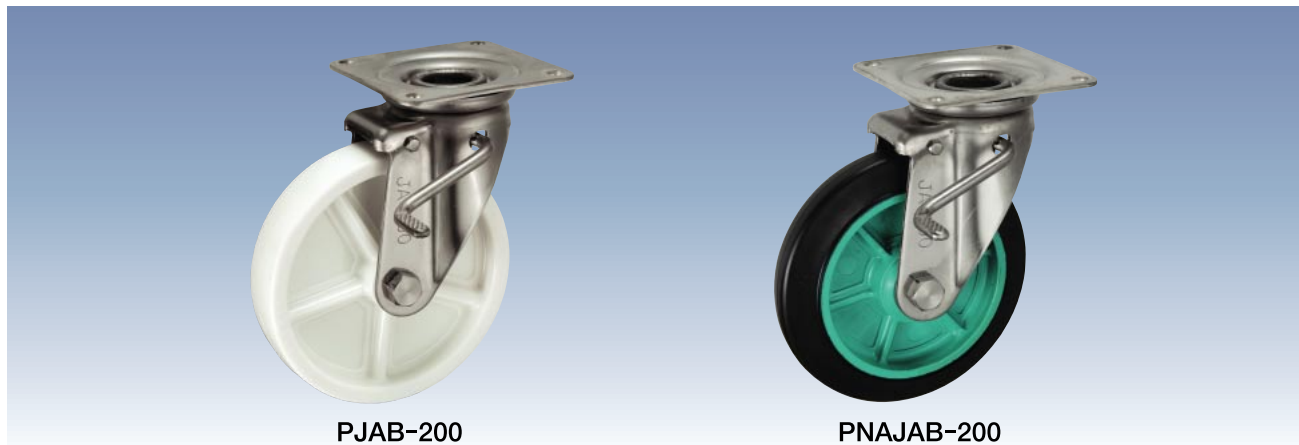



Size: 200mm

Stainless Steel Swivel Bracket with Stopper



PJAB-200

PNAJAB-200

Size 	Model Number	Wheel	Bearing	Load Capacity		Tire Width R 	Shaft Diameter D 	Overall Height H1 	Plate Size F1/F2 	Mounting Hole Spacing P1/P2 	Plate Hole d 	Offset E 	Weight (g) 	
				(daN)	(kgf)									
200	■ Nylon													
	PJAB-200	Nylon		250	255.0	45	20	250	140/140	112/112	11	58	3,120	
	PBJAB-200	Nylon	B/B	400	408.0								3,330	
	PBDJAB-200	Nylon	SUS										3,330	
	■ Nylon Rim · Rubber Wheel													
	PNJAB-200	Rubber	B/B	220	224.4	42	20	250	140/140	112/112	11	58	3,400	
	PNDJAB-200	Rubber	SUS										3,400	
	PNAJAB-200	Rubber											160	163.2
	■ Nylon Rim · Urethane Rubber Wheel													
	PNUJAB-200	Urethane	B/B	350	357.0	42	20	250	140/140	112/112	11	58	3,270	
	PNUDJAB-200	Urethane	SUS										3,270	
	PNUAJAB-200	Urethane											250	255.0
	■ Monomer Cast Nylon													
	UWBJAB-200	MC Nylon	B/B	500	510.0	42	20	250	140/140	112/112	11	58	4,280	
	UWBDJAB-200	MC Nylon	SUS										4,280	
	UWAJAB-200	MC Nylon											4,130	
	UWBSJAB-200	MC Nylon	B/B										3,740	
	UWBSDJAB-200	MC Nylon	SUS			34	3,740							
	■ Steel Rim · Rubber Wheel <i>Wheel rim is not stainless steel.</i>													
	SJAB-200	Rubber	B/B	250	255.0	45	20	250	140/140	112/112	11	58	4,050	
SRJAB-200	Red Rubber	B/B	200	204.0	4,050									
SHJAB-200	High-Rebound	B/B	250	255.0	4,050									
CRJAB-200	Heat-resistance	B/B			4,130									
■ Steel Rim · Urethane Rubber Wheel <i>Wheel rim is not stainless steel.</i>														
SUIJAB-200	Urethane	B/B	400	408.0	42	20	250	140/140	112/112	11	58	4,220		
SUIEJAB-200	Anti-Static	B/B										4,220		

Unit: mm

●The stopper pedal for left foot is not available.

Bearing: No mark -- Spindle sleeve, B/B -- Steel bearing, SUS -- Stainless steel bearing

 Build-to-order manufacturing

The JAB Type bracket can lock or unlock the wheel and frame at the same time just by stepping the pedal.

●The materials of JAB Type bracket are all stainless steel (SUS 304 / 18-8 stainless), except plate springs.

For plate springs, SK5 (carbon tool steel) is used for maintaining spring performance, and the surface is plated with nickel chrome.

JAB_{Type}



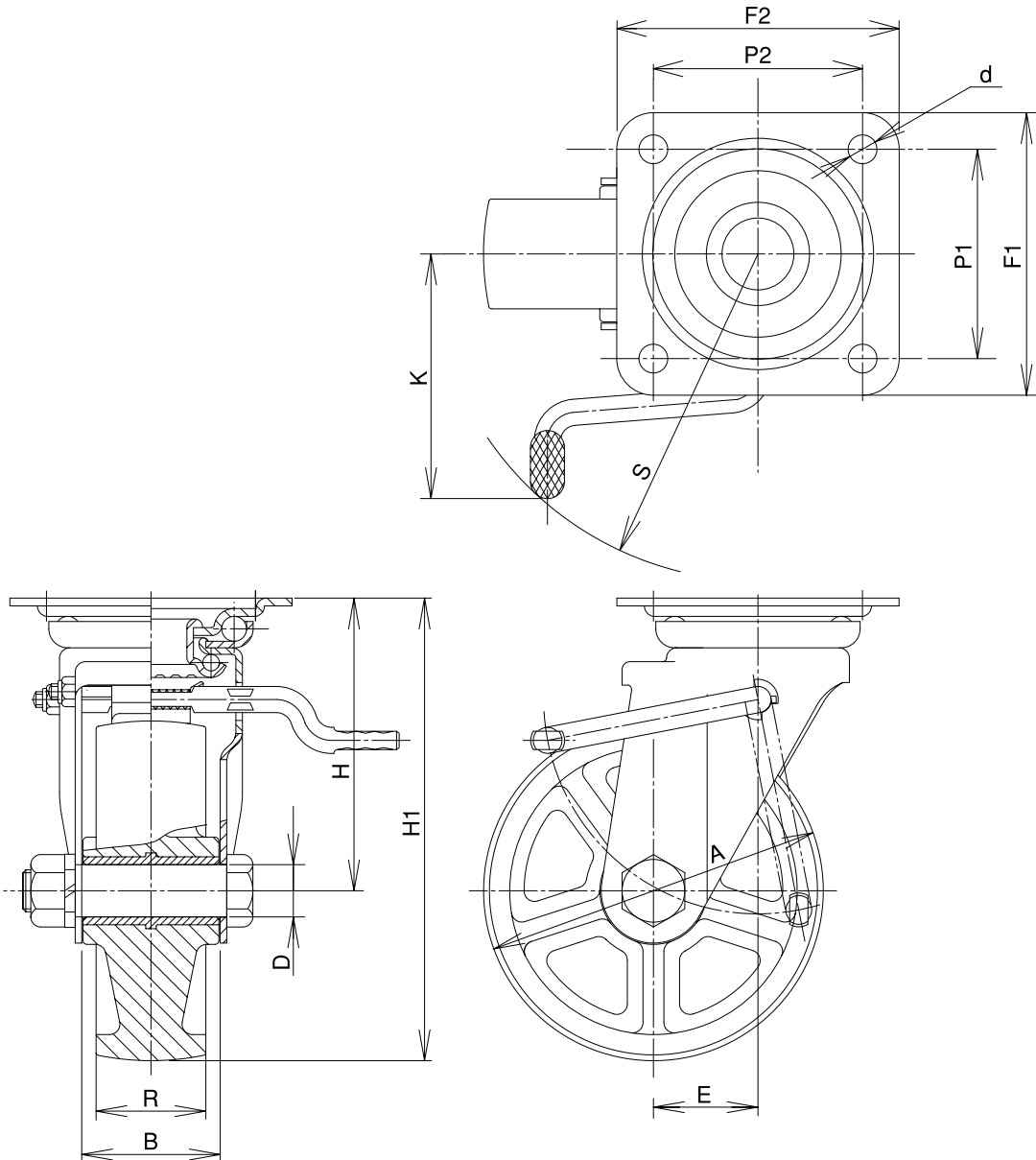

Stainless Steel Swivel Bracket with Stopper

Stainless Steel Caster Series





[Bracket Dimensions]

Unit: mm

Size 	Load Capacity		Bracket Height H 	Bracket Width B 	Weight (g) 
	(daN)	(kgf)			
75	150	153.0	63	40	380
100	200	204.0	94	43	830
130	300	306.0	112	53	1,260
150	350	357.0	123	56	1,670
200	500	510.0	150	56	2,380

[Pedal Dimensions]

Unit: mm

Size 	Pedal Rod K 	Radius of Gyration S 
75	65	82
100	92	112
130	105	135
150	108	140
200	120	148

Notice

The materials of JAB Type bracket are all stainless steel, but the following wheels are not stainless steel. In addition, stainless steel bearings cannot be set.
Please be careful when selecting a caster.

Steel Rim·Rubber Wheel (S, SR, SH, CR Type)
Steel Rim·Urethane Wheel (SUI, SUIE Type)

* The shaft set is included in the bracket.

KABZ_{Type}

Size: 75mm

Stainless Steel Rigid Bracket with Stopper

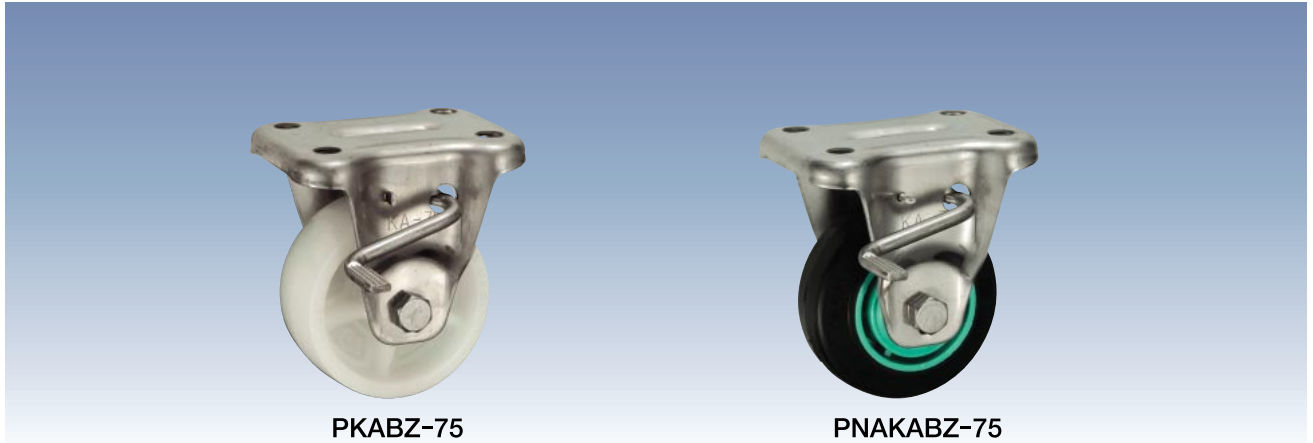

PKABZ-75

PNAKABZ-75

Size 	Model Number	Wheel	Bearing	Load Capacity		Tire Width R	Shaft Diameter D	Overall Height H1	Plate Size F1/F2	Mounting Hole Spacing P1/P2	Plate Hole d	Weight (g)
				(daN)	(kgf)							
75	■ Nylon											
	PKABZ-75	Nylon		100	102.0	32	10	101	91/68	63/40	9.5	360
	PBKABZ-75	Nylon	B/B	120	122.4							420
	PBDKABZ-75	Nylon	SUS									420
	■ Nylon Rim · Rubber Wheel											
	PNKABZ-75	Rubber	B/B	70	71.4	32	10	101	91/68	63/40	9.5	450
	PNDKABZ-75	Rubber	SUS									450
	PNAKABZ-75	Rubber										410
	■ Nylon Rim · Urethane Rubber Wheel											
	PNUKABZ-75	Urethane	B/B	100	102.0	32	10	101	91/68	63/40	9.5	440
	PNUDKABZ-75	Urethane	SUS									440
	PNUAKABZ-75	Urethane										390
	■ Monomer Cast Nylon											
	UWBKABZ-75	MC Nylon	B/B	150	153.0	24	10	101	91/68	63/40	9.5	460
	UWBDKABZ-75	MC Nylon	SUS									460
	UWAKABZ-75	MC Nylon										420
	UWBSKABZ-75	MC Nylon	B/B									440
	UWBSDKABZ-75	MC Nylon	SUS			26	440					
	■ Steel Rim · Rubber Wheel <i>Wheel rim is not stainless steel.</i>											
	SKABZ-75	Rubber	B/B	80	81.6	32	10	101	91/68	63/40	9.5	470
	SRKABZ-75	Red Rubber	B/B	60	61.2							470
CRKABZ-75	Heat-resistance	B/B	80	81.6	490							
■ Steel Rim · Urethane Rubber Wheel <i>Wheel rim is not stainless steel.</i>												
SUIKABZ-75	Urethane	B/B	120	122.4	32	10	101	91/68	63/40	9.5	550	
SUIEKABZ-75	Anti-Static	B/B									550	

Unit: mm

● The stopper pedal for left foot is available (KABZ-75 → KABZL-75).

Bearing: No mark -- Spindle sleeve, B/B -- Steel bearing, SUS -- Stainless steel bearing

 Build-to-order manufacturing

The stopper of the KABZ Type bracket can lock the wheel to stop the caster.

● The materials of KABZ Type bracket are all stainless steel (SUS 304 / 18-8 stainless), except plate springs. For plate springs, SK5 (carbon tool steel) is used for maintaining spring performance, and the surface is plated with nickel chrome.

KABZ_{Type}

Size: 100mm

Stainless Steel Rigid Bracket with Stopper



PKABZ-100

PNAKABZ-100

Unit: mm

Size 	Model Number	Wheel	Bearing	Load Capacity		Tire Width R	Shaft Diameter D	Overall Height H1	Plate Size F1/F2	Mounting Hole Spacing P1/P2	Plate Hole d	Weight (g)	
				(daN)	(kgf)								
100	■ Nylon												
	PKABZ-100	Nylon		120	122.4	35	12	144	115/80	80/45	11	690	
	PBKABZ-100	Nylon	B/B	180	183.6							750	
	PBDKABZ-100	Nylon	SUS									750	
	■ Nylon Rim · Rubber Wheel												
	PNKABZ-100	Rubber	B/B	100	102.0	32	12	144	115/80	80/45	11	790	
	PNDKABZ-100	Rubber	SUS									790	
	PNAKABZ-100	Rubber										730	
	■ Nylon Rim · Urethane Rubber Wheel												
	PNUKABZ-100	Urethane	B/B	150	153.0	32	12	144	115/80	80/45	11	770	
	PNUDKABZ-100	Urethane	SUS									770	
	PNUAKABZ-100	Urethane										710	
	■ Monomer Cast Nylon												
	UWBKABZ-100	MC Nylon	B/B	200	204.0	29	12	144	115/80	80/45	11	900	
	UWBDKABZ-100	MC Nylon	SUS									900	
	UWAKABZ-100	MC Nylon										850	
	UWBSKABZ-100	MC Nylon	B/B									850	
	UWBSDKABZ-100	MC Nylon	SUS			30	850						
	■ Steel Rim · Rubber Wheel Wheel rim is not stainless steel.												
	SKABZ-100	Rubber	B/B	130	132.6	35	12	144	115/80	80/45	11	890	
SRKABZ-100	Red Rubber	B/B	100	102.0	890								
CRKABZ-100	Heat-resistance	B/B	130	132.6	920								
■ Steel Rim · Urethane Rubber Wheel Wheel rim is not stainless steel.													
SUIKABZ-100	Urethane	B/B	180	183.6	32	12	144	115/80	80/45	11	960		
SUIEKABZ-100	Anti-Static	B/B									960		

● The stopper pedal for left foot is available (KABZ-100 → KABZL-100).

Bearing: No mark -- Spindle sleeve, B/B -- Steel bearing, SUS -- Stainless steel bearing

 Build-to-order manufacturing

The stopper of the KABZ Type bracket can lock the wheel to stop the caster.

● The materials of KABZ Type bracket are all stainless steel (SUS 304 / 18-8 stainless), except plate springs.

For plate springs, SK5 (carbon tool steel) is used for maintaining spring performance, and the surface is plated with nickel chrome.

KABZ_{Type}

Size: 130mm

Stainless Steel Rigid Bracket with Stopper

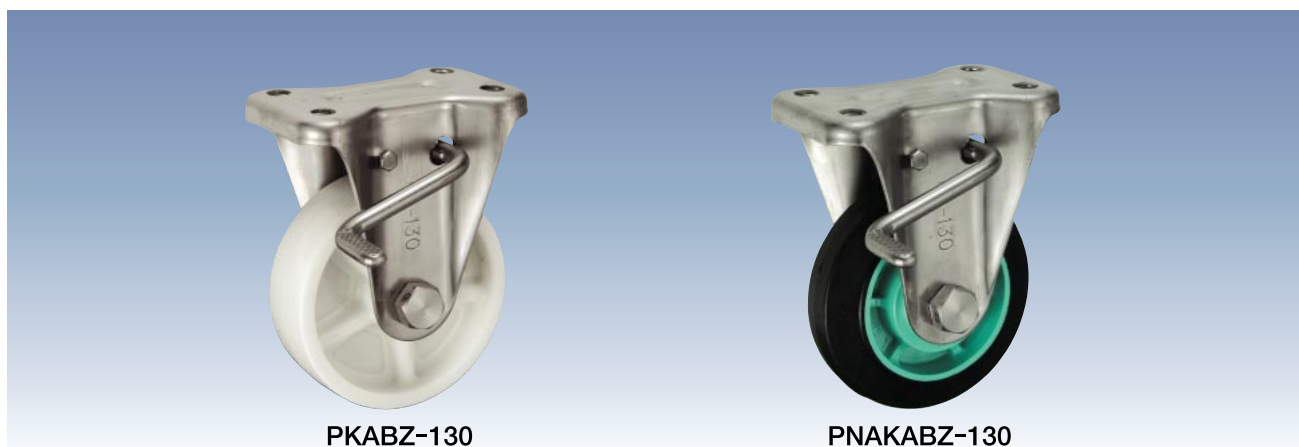

PKABZ-130

PNAKABZ-130

Size 	Model Number	Wheel	Bearing	Load Capacity		Tire Width R	Shaft Diameter D	Overall Height H1	Plate Size F1/F2	Mounting Hole Spacing P1/P2	Plate Hole d	Weight (g)	
				(daN)	(kgf)								
130	■ Nylon												
	PKABZ-130	Nylon		150	153.0	42	20	177	137/93	100/56	11	1,310	
	PBKABZ-130	Nylon	B/B	250	255.0							1,510	
	PBDKABZ-130	Nylon	SUS									1,510	
	■ Nylon Rim · Rubber Wheel												
	PNKABZ-130	Rubber	B/B	145	147.9	38	20	177	137/93	100/56	11	1,570	
	PNDKABZ-130	Rubber	SUS									1,570	
	PNAKABZ-130	Rubber										1,380	
	■ Nylon Rim · Urethane Rubber Wheel												
	PNUKABZ-130	Urethane	B/B	200	204.0	35	20	177	137/93	100/56	11	1,510	
	PNUDKABZ-130	Urethane	SUS									1,510	
	PNUAKABZ-130	Urethane										1,320	
	■ Monomer Cast Nylon												
	UWBKABZ-130	MC Nylon	B/B	300	306.0	36	20	177	137/93	100/56	11	1,790	
	UWBDKABZ-130	MC Nylon	SUS									1,790	
	UWAKABZ-130	MC Nylon										1,640	
	UWBSKABZ-130	MC Nylon	B/B									1,530	
	UWBSDKABZ-130	MC Nylon	SUS			30	1,530						
	■ Steel Rim · Rubber Wheel Wheel rim is not stainless steel.												
	SKABZ-130	Rubber	B/B	180	183.6	42	20	177	137/93	100/56	11	1,770	
SRKABZ-130	Red Rubber	B/B	140	142.8	1,770								
CRKABZ-130	Heat-resistance	B/B	180	183.6	1,800								
■ Steel Rim · Urethane Rubber Wheel Wheel rim is not stainless steel.													
SUIKABZ-130	Urethane	B/B	250	255.0	35	20	177	137/93	100/56	11	1,900		
SUIEKABZ-130	Anti-Static	B/B									1,900		

Unit: mm

● The stopper pedal for left foot is available (KABZ-130 → KABZL-130).

Bearing: No mark -- Spindle sleeve, B/B -- Steel bearing, SUS -- Stainless steel bearing

Build-to-order manufacturing

The stopper of the KABZ Type bracket can lock the wheel to stop the caster.

● The materials of KABZ Type bracket are all stainless steel (SUS 304 / 18-8 stainless), except plate springs.

For plate springs, SK5 (carbon tool steel) is used for maintaining spring performance, and the surface is plated with nickel chrome.

KABZ_{Type}

Size: 150mm

Stainless Steel Rigid Bracket with Stopper



PKABZ-150



PNAKABZ-150

Stainless Steel Caster Series

Unit: mm

Size 	Model Number	Wheel	Bearing	Load Capacity		Tire Width R 	Shaft Diameter D 	Overall Height H1 	Plate Size F1/F2 	Mounting Hole Spacing P1/P2 	Plate Hole d 	Weight (g) 	
				(daN)	(kgf)								
150	■ Nylon												
	PKABZ-150	Nylon		180	183.6	45	20	198	137/93	100/56	11	1,560	
	PBKABZ-150	Nylon	B/B	300	306.0							1,800	
	PBDKABZ-150	Nylon	SUS									1,800	
	■ Nylon Rim · Rubber Wheel												
	PNKABZ-150	Rubber	B/B	175	178.5	38	20	198	137/93	100/56	11	1,820	
	PNDKABZ-150	Rubber	SUS									1,820	
	PNAKABZ-150	Rubber										140	142.8
	■ Nylon Rim · Urethane Rubber Wheel												
	PNUKABZ-150	Urethane	B/B	250	255.0	38	20	198	137/93	100/56	11	1,780	
	PNUDKABZ-150	Urethane	SUS									1,780	
	PNUAKABZ-150	Urethane										150	153.0
	■ Monomer Cast Nylon												
	UWBKABZ-150	MC Nylon	B/B	350	357.0	40	20	198	137/93	100/56	11	2,240	
	UWBDKABZ-150	MC Nylon	SUS									2,240	
	UWAKABZ-150	MC Nylon										2,090	
	UWBSKABZ-150	MC Nylon	B/B									1,840	
	UWBSDKABZ-150	MC Nylon	SUS			30	1,840						
	■ Steel Rim · Rubber Wheel Wheel rim is not stainless steel.												
	SKABZ-150	Rubber	B/B	200	204.0	45	20	198	137/93	100/56	11	2,110	
SRKABZ-150	Red Rubber	B/B	160	163.2	2,110								
CRKABZ-150	Heat-resistance	B/B	200	204.0	2,150								
■ Steel Rim · Urethane Rubber Wheel Wheel rim is not stainless steel.													
SUIKABZ-150	Urethane	B/B	300	306.0	38	20	198	137/93	100/56	11	2,300		
SUIEKABZ-150	Anti-Static	B/B									2,300		

● The stopper pedal for left foot is available (KABZ-150 → KABZL-150).

Bearing: No mark -- Spindle sleeve, B/B -- Steel bearing, SUS -- Stainless steel bearing

 Build-to-order manufacturing

The stopper of the KABZ Type bracket can lock the wheel to stop the caster.

● The materials of KABZ Type bracket are all stainless steel (SUS 304 / 18-8 stainless), except plate springs.

For plate springs, SK5 (carbon tool steel) is used for maintaining spring performance, and the surface is plated with nickel chrome.

KABZ_{Type}

Size: 200mm

Stainless Steel Rigid Bracket with Stopper

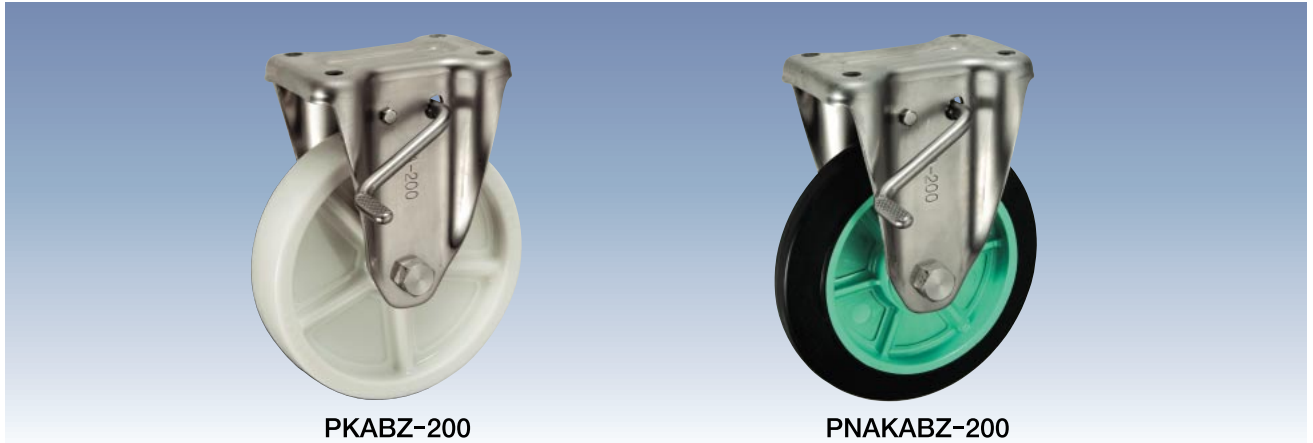

PKABZ-200

PNAKABZ-200

Size 	Model Number	Wheel	Bearing	Load Capacity		Tire Width R	Shaft Diameter D	Overall Height H1	Plate Size F1/F2	Mounting Hole Spacing P1/P2	Plate Hole d	Weight (g)	
				(daN)	(kgf)								
200	■ Nylon												
	PKABZ-200	Nylon		250	255.0	45	20	250	151/102	112/63	11	2,520	
	PBKABZ-200	Nylon	B/B	400	408.0							2,730	
	PBDKABZ-200	Nylon	SUS									2,730	
	■ Nylon Rim · Rubber Wheel												
	PNKABZ-200	Rubber	B/B	220	224.4	42	20	250	151/102	112/63	11	2,800	
	PNDKABZ-200	Rubber	SUS									2,800	
	PNAKABZ-200	Rubber										2,630	
	■ Nylon Rim · Urethane Rubber Wheel												
	PNUKABZ-200	Urethane	B/B	350	357.0	42	20	250	151/102	112/63	11	2,670	
	PNUDKABZ-200	Urethane	SUS									2,670	
	PNUAKABZ-200	Urethane										2,500	
	■ Monomer Cast Nylon												
	UWBKABZ-200	MC Nylon	B/B	500	510.0	42	20	250	151/102	112/63	11	3,680	
	UWBDKABZ-200	MC Nylon	SUS									3,680	
	UWAKABZ-200	MC Nylon										3,530	
	UWBSKABZ-200	MC Nylon	B/B			34						3,140	
	UWBSDKABZ-200	MC Nylon	SUS									3,140	
	■ Steel Rim · Rubber Wheel <i>Wheel rim is not stainless steel.</i>												
	SKABZ-200	Rubber	B/B	250	255.0	45	20	250	151/102	112/63	11	3,450	
	SRKABZ-200	Red Rubber	B/B	200	204.0							3,450	
	SHKABZ-200	High-Rebound	B/B	250	255.0							3,450	
CRKABZ-200	Heat-resistance	B/B	3,530										
■ Steel Rim · Urethane Rubber Wheel <i>Wheel rim is not stainless steel.</i>													
SUIKABZ-200	Urethane	B/B	400	408.0	42	20	250	151/102	112/63	11	3,620		
SUIEKABZ-200	Anti-Static	B/B									3,620		

Unit: mm

● The stopper pedal for left foot is available (KABZ-200 → KABZL-200).

Bearing: No mark -- Spindle sleeve, B/B -- Steel bearing, SUS -- Stainless steel bearing

 Build-to-order manufacturing

The stopper of the KABZ Type bracket can lock the wheel to stop the caster.

● The materials of KABZ Type bracket are all stainless steel (SUS 304 / 18-8 stainless), except plate springs.

For plate springs, SK5 (carbon tool steel) is used for maintaining spring performance, and the surface is plated with nickel chrome.

KABZ_{Type}

Stainless Steel Rigid Bracket with Stopper

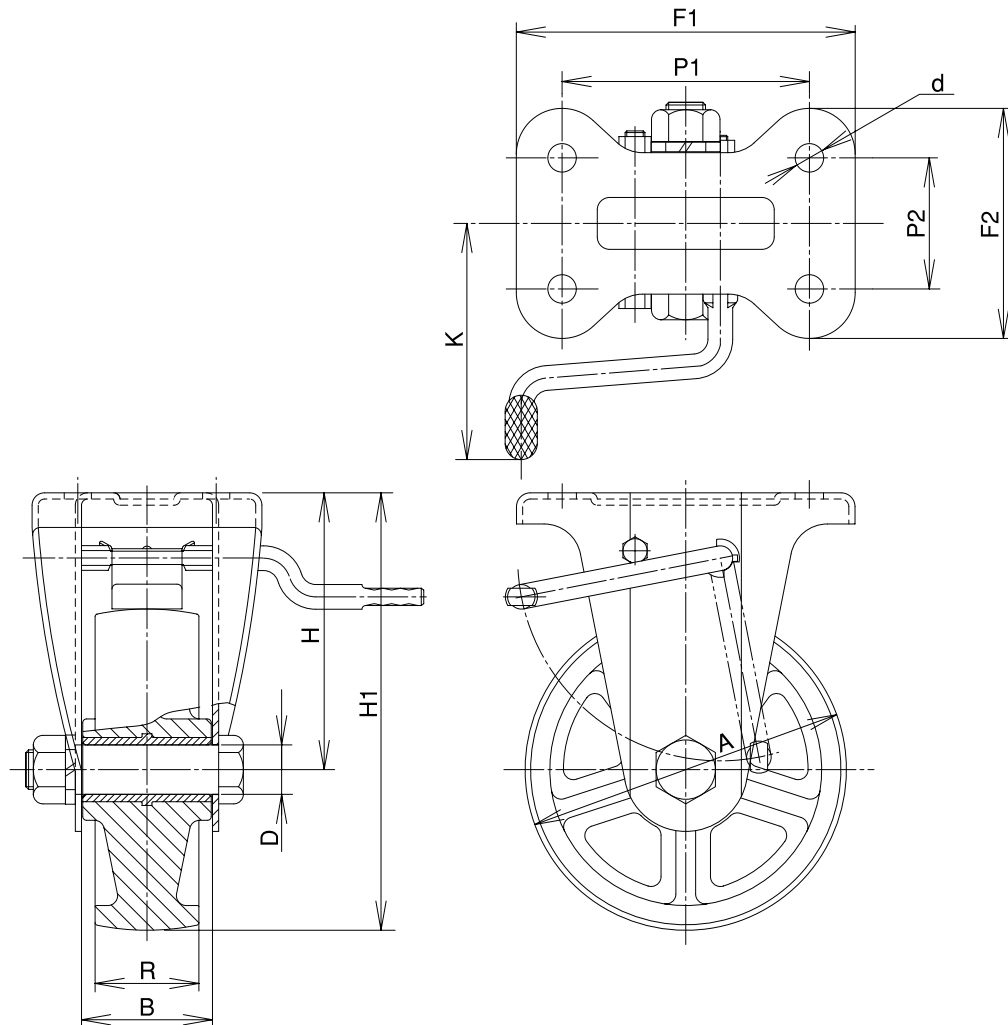

Stainless Steel Caster Series

[Bracket Dimensions]

Unit: mm

Size 	Load Capacity 		Bracket Height H 	Bracket Width B 	Weight (g)
	(daN)	(kgf)			
75	150	153.0	63	40	270
100	200	204.0	94	43	530
130	300	306.0	112	53	990
150	350	357.0	123	56	1,150
200	500	510.0	150	56	1,780

[Pedal Dimensions]

Unit: mm

Size 	Pedal Rod K
75	72
100	100
130	112
150	112
200	112

Notice

The materials of KABZ Type bracket are all stainless steel, but the following wheels are not stainless steel. In addition, stainless steel bearings cannot be set. Please be careful when selecting a caster.

Steel Rim • Rubber Wheel (S, SR, SH, CR Type)
Steel Rim • Urethane Wheel (SUI, SUIE Type)

* The shaft set is included in the bracket.

Heavy Duty (Small Type) Caster Series

JM Type

Size: 50mm~75mm

Heavy Duty Swivel Bracket (Small Type)



RGNJM-65 CP

RFJM-65 CP

RRJM-65 CP

Size A	Model Number	Wheel	Bearing	Load Capacity		Tire Width R	Shaft Diameter D	Overall Height H1	Plate Size F1/F2	Mounting Hole Spacing P1/P2	Plate Hole d	Offset E	Weight (g)
				(daN)	(kgf)								
50	RGNJM-50 CP	Reinforced Nylon	B/B	200	204.0	28	10	72	65/65	50/50	6.2	25	420
	RRJM-50 CP	MC Nylon	B/B			27							420
	SUIJM-50 CP	Urethane	B/B	80	81.6	20.5							450
	FJM-50 CP	Steel	B/B	100	102.0	27							630
	FAJM-50 CP	Steel		60	61.2								700
65 ※	RGNJM-65 CP	Reinforced Nylon	B/B	300	306.0	38	12	92	90/90	71/71	10.5	35	1,070
	RFJM-65 CP	Urethane	B/B	170	173.4	34							1,250
	RRJM-65 CP	MC Nylon	B/B	300	306.0								1,030
75 ※	RGNJM-75 CP	Reinforced Nylon	B/B	400	408.0	38	12	105	90/90	71/71	10.5	35	1,150
	RFJM-75 CP	Urethane	B/B	200	204.0								1,160
	RRJM-75 CP	MC Nylon	B/B	400	408.0	36							1,110

Unit: mm

※ It is possible to attach an AD-12 bracket-mounted adjuster to JM-65 and JM-75 brackets (Page 64).

Bearing: No mark -- Spindle sleeve, B/B -- Steel bearing

Bracket: White Plating (Written as "CP")

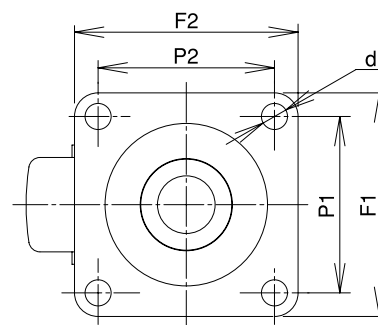

[Bracket Dimensions]

Size A	Load Capacity		Bracket Height H	Bracket Width B	Weight (g)
	(daN)	(kgf)			
50	200	204.0	47	32	310
65	300	306.0	60	40	850
75	400	408.0	68	40	880

Unit: mm

* The shaft set is included in the bracket.

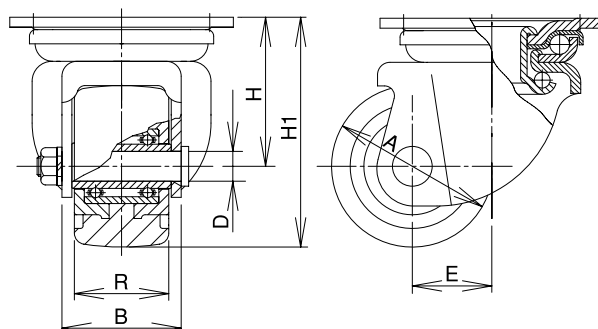

AD-12/AE-12_{Type}

Adjuster with the Bracket



AD-12 CP

Unit: mm

Model Number	Load Capacity		Max. Height Hmax	Min. Height Hmin	Adjustment a	Weight (g)	Compatible Caster
	(daN)	(kgf)					
AD-12 CP	400	408.0	115	83	32	350	JM-65/JM-75

White Plating (Written as "CP")

[Adjuster Dimensions]

Unit: mm

Model Number	Load Capacity		Bolt Diameter P	Bolt Length		Foot Diameter ϕN	Lock Nut		Weight (g)
	(daN)	(kgf)		L1	L2		s	m	
AE-12 CP	400	408.0	M12×P1.25	52	75	40	17	10	110

White Plating (Written as "CP")

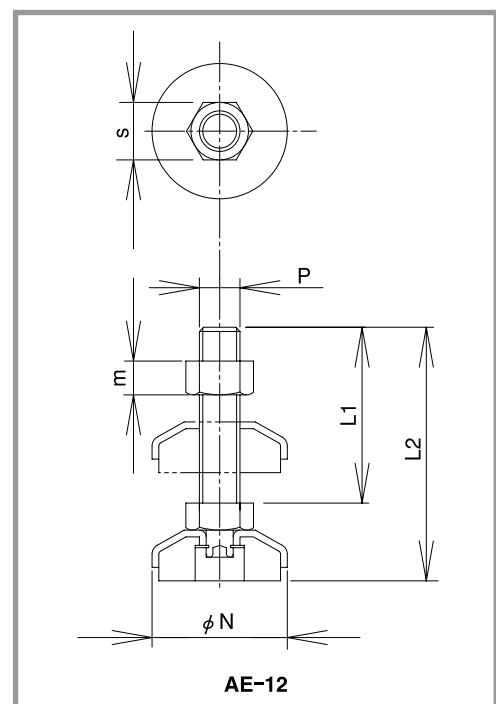
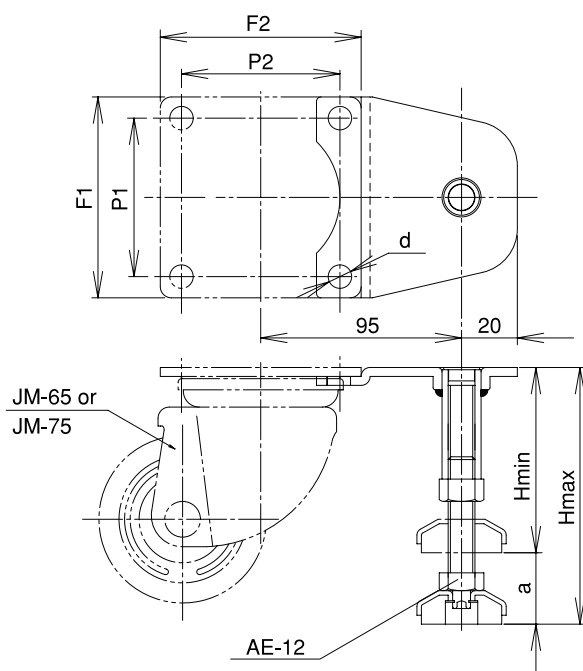

KH Type

Size: 50mm



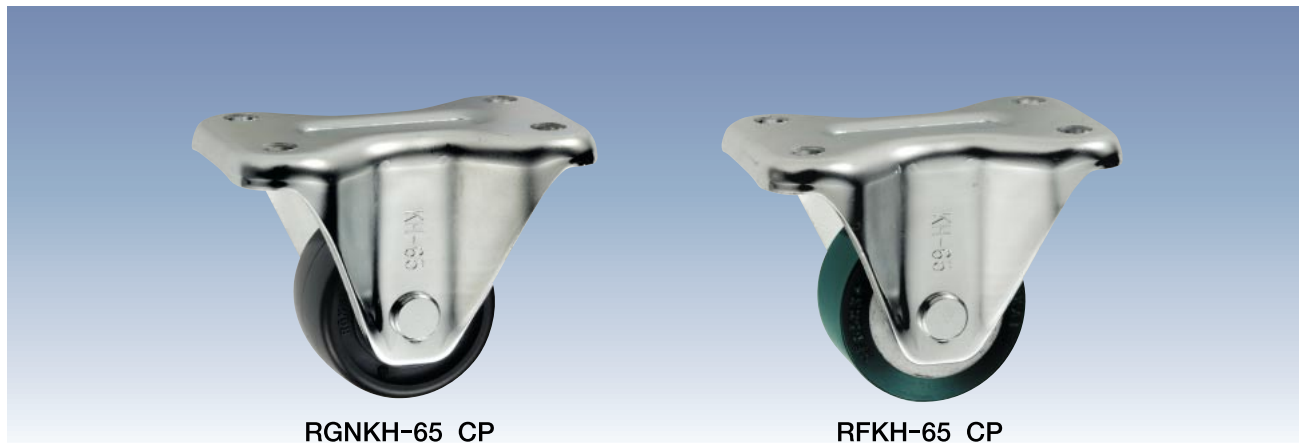





Heavy Duty Rigid Bracket (Small Type)



RGNKH-65 CP

RFKH-65 CP

Unit: mm





Size 	Model Number	Wheel	Bearing	Load Capacity		Tire Width R 	Shaft Diameter D 	Overall Height H1 	Plate Size F1/F2 	Mounting Hole Spacing P1/P2 	Plate Hole d 	Weight (g) 
				(daN)	(kgf)							
50	RGNKH-50 CP	Reinforced Nylon	B/B	200	204.0	28	10	72	82/52	66/36	6.2	290
	RRKH-50 CP	MC Nylon	B/B									290
	SUIKH-50 CP	Urethane	B/B	80	81.6	20.5						320
	FKH-50 CP	Steel	B/B	100	102.0	27						500
	FAKH-50 CP	Steel		60	61.2							570

Bearing: No mark -- Spindle sleeve, B/B -- Steel bearing

Bracket: White Plating (Written as "CP")

[Bracket Dimensions]

Unit: mm

Size 	Load Capacity		Bracket Height H 	Bracket Width B 	Weight (g) 
	(daN)	(kgf)			
50	200	204.0	47	32	180
65	300	306.0	60	40	450
75	400	408.0	68	40	540

* The shaft set is included in the bracket.

KH Type

Size: 65mm~75mm

Heavy Duty Rigid Bracket (Small Type)



RRKH-65 CP

Unit: mm

Size 	Model Number	Wheel	Bearing	Load Capacity		Tire Width R 	Shaft Diameter D 	Overall Height H1 	Plate Size F1/F2 	Mounting Hole Spacing P1/P2 	Plate Hole d 	Weight (g)
				(daN)	(kgf)							
65	RG NKH-65 CP	Reinforced Nylon	B/B	300	306.0	38	12	92	124/80	91/47	10.5	670
	RF KH-65 CP	Urethane	B/B	170	173.4	34						850
	RR KH-65 CP	MC Nylon	B/B	300	306.0	34						630
75	RG NKH-75 CP	Reinforced Nylon	B/B	400	408.0	38	12	105	136/85	103/52	10.5	810
	RF KH-75 CP	Urethane	B/B	200	204.0	36						820
	RR KH-75 CP	MC Nylon	B/B	400	408.0	36						770

Bearing: No mark -- Spindle sleeve, B/B -- Steel bearing

Bracket: White Plating (Written as "CP")

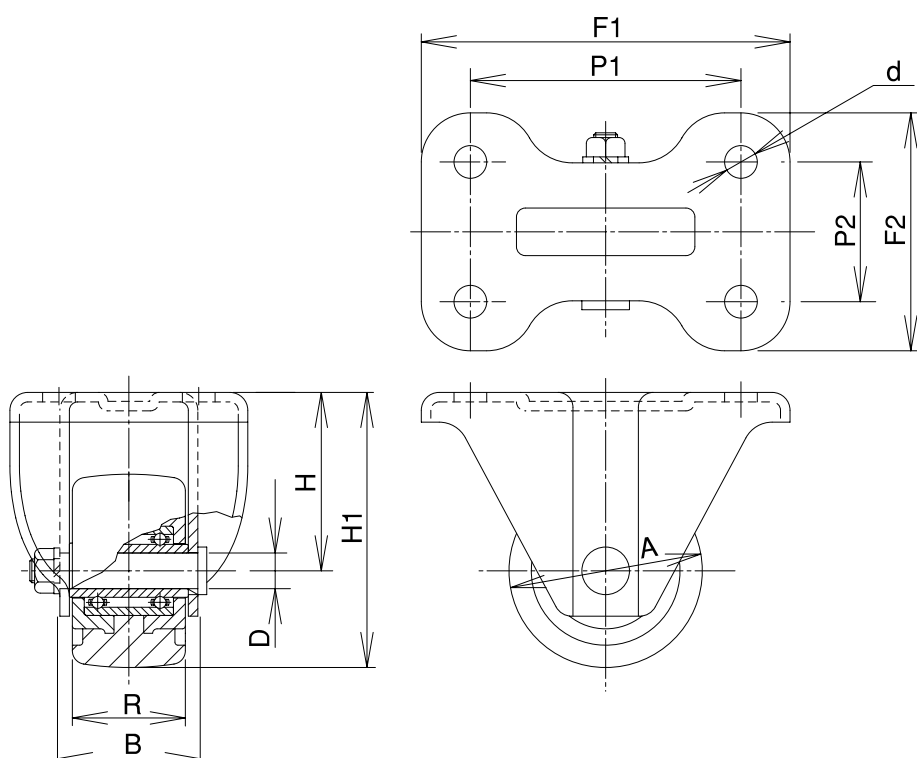

JM Type

Size: 100mm~130mm

Heavy Duty Swivel Bracket

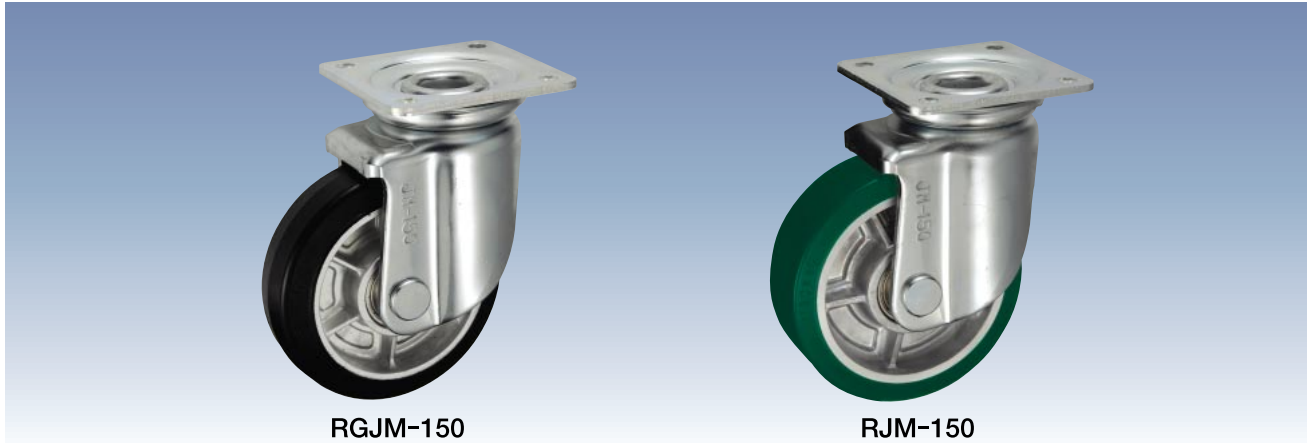

RGJM-150

RJM-150

Unit: mm

Size 	Model Number	Wheel	Bearing	Load Capacity		Tire Width R 	Shaft Diameter D 	Overall Height H1 	Plate Size F1/F2 	Mounting Hole Spacing P1/P2 	Plate Hole d 	Offset E 	Weight (g)
				(daN)	(kgf)								
100	RGNJM-100	Reinforced Nylon	B/B	460	469.2	45	12	144	108/108	80/80	11	37	1,940
	RGJM-100	Aluminum Rim·Rubber	B/B	200	204.0								1,970
	RJM-100	Aluminum Rim·Urethane	B/B	300	306.0	50							1,970
	RFJM-100	Steel Rim·Urethane	B/B			45							1,980
	RRJM-100	MC Nylon	B/B	460	469.2	29							1,880
	UWBJM-100	MC Nylon	B/B			29							1,820
130	RGJM-130	Aluminum Rim·Rubber	B/B	240	244.8	50	20	177	108/108	80/80	11	40	2,830
	RJM-130	Aluminum Rim·Urethane	B/B	450	459.0								36
	RFJM-130	Steel Rim·Urethane	B/B			500							510.0
	RRJM-130	Aluminum Rim·MC Nylon	B/B	500	510.0								
	UWBJM-130	MC Nylon	B/B			500							510.0

Bearing: B/B -- Steel bearing

[Bracket Dimensions]

Unit: mm

Size 	Load Capacity		Bracket Height H 	Bracket Width B 	Weight (g)
	(daN)	(kgf)			
100	460	469.2	94	57	1,440
130	500	510.0	112	60	1,920
150	550	561.0	123	60	2,490
200	660	673.2	150	71	3,860

* The shaft set is included in the bracket.

JM Type

Size: 150mm~200mm

Heavy Duty Swivel Bracket



RFJM-150



RRJM-150

Unit: mm

Size 	Model Number	Wheel	Bearing	Load Capacity		Tire Width R	Shaft Diameter D	Overall Height H1	Plate Size F1/F2	Mounting Hole Spacing P1/P2	Plate Hole d	Offset E	Weight (g)
				(daN)	(kgf)								
150	RGJM-150	Aluminum Rim·Rubber	B/B	300	306.0	50	20	198	120/120	90/90	11	45	3,620
	RJM-150	Aluminum Rim·Urethane	B/B	500	510.0								3,730
	RFJM-150	Steel Rim·Urethane	B/B	500	510.0								3,790
	RRJM-150	Aluminum Rim·MC Nylon	B/B	550	561.0								3,730
	UWBJM-150	MC Nylon	B/B	40	550								561.0
200	RGJM-200	Steel Rim·Rubber	B/B	410	418.2	63	25	250	140/140	112/112	14	58	6,420
	RFJM-200	Steel Rim·Urethane	B/B	600	612.0								6,430
	RRJM-200	Aluminum Rim·MC Nylon	B/B	660	673.2								6,270
	UWBJM-200	MC Nylon	B/B	42	660								673.2

Bearing: B/B -- Steel bearing

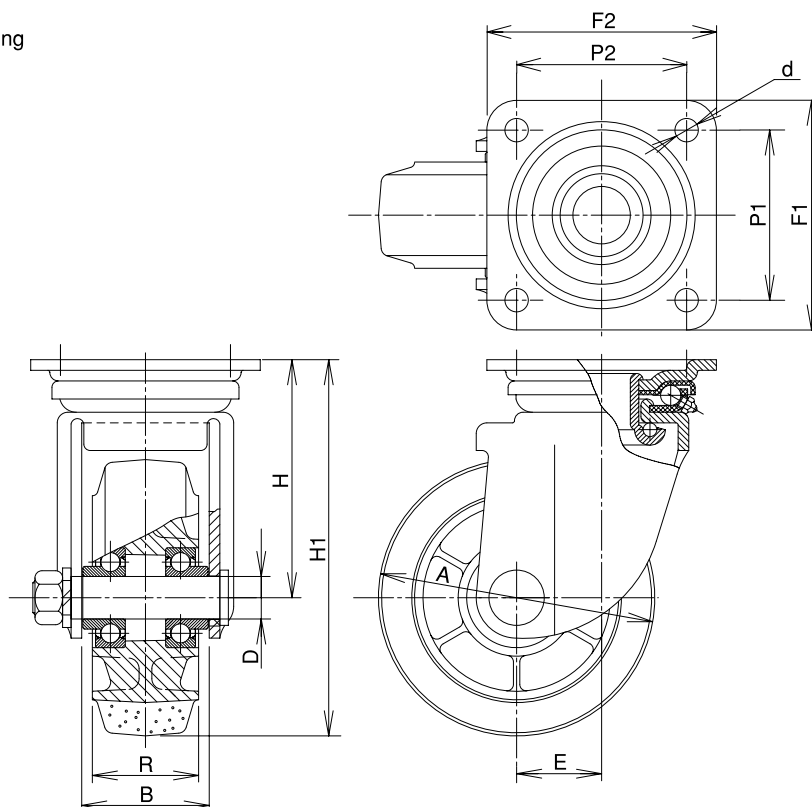







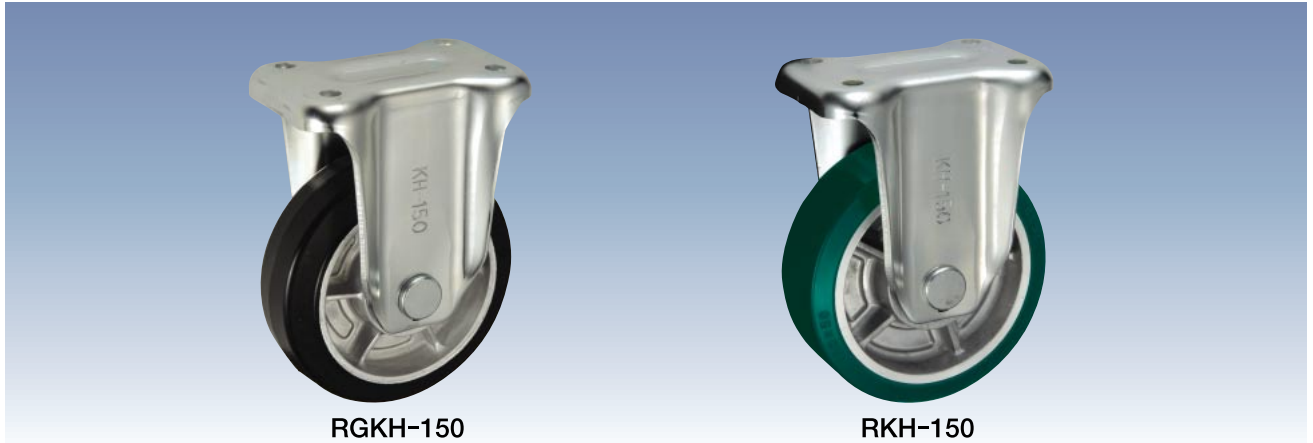

KH Type

Size: 100mm~130mm

Heavy Duty Rigid Bracket







Size 	Model Number	Wheel	Bearing	Load Capacity 		Tire Width R 	Shaft Diameter D 	Overall Height H1 	Plate Size F1/F2 	Mounting Hole Spacing P1/P2 	Plate Hole d 	Weight (g) 
				(daN)	(kgf)							
100	RGKHX-100	Reinforced Nylon	B/B	460	469.2	45	12	144	139/88	103/52	11	1,450
	RGKH-100	Aluminum Rim·Rubber	B/B	200	204.0	45						1,480
	RKH-100	Aluminum Rim·Urethane	B/B	300	306.0	50						1,480
	RFKH-100	Steel Rim·Urethane	B/B	460	469.2	45						1,490
	RRKH-100	MC Nylon	B/B	460	469.2	29						1,390
	UWBKH-100	MC Nylon	B/B	460	469.2	29						1,330
130	RGKH-130	Aluminum Rim·Rubber	B/B	240	244.8	50	20	177	140/96	100/56	11	2,400
	RKH-130	Aluminum Rim·Urethane	B/B	450	459.0	50						2,540
	RFKH-130	Steel Rim·Urethane	B/B	500	510.0	36						2,570
	RRKH-130	Aluminum Rim·MC Nylon	B/B	500	510.0	36						2,550
	UWBKH-130	MC Nylon	B/B	500	510.0	36						2,300

Unit: mm

Bearing: B/B -- Steel bearing

[Bracket Dimensions]

Unit: mm

Size 	Load Capacity 		Bracket Height H 	Bracket Width B 	Weight (g) 
	(daN)	(kgf)			
100	460	469.2	94	57	950
130	500	510.0	112	60	1,490
150	550	561.0	123	60	1,520
200	660	673.2	150	71	2,260

* The shaft set is included in the bracket.

KH Type

Size: 150mm~200mm

Heavy Duty Rigid Bracket



RFKH-150



RRKH-150

Unit: mm

Size 	Model Number	Wheel	Bearing	Load Capacity 		Tire Width R 	Shaft Diameter D 	Overall Height H1 	Plate Size F1/F2 	Mounting Hole Spacing P1/P2 	Plate Hole d 	Weight (g)
				(daN)	(kgf)							
150	RGKH-150	Aluminum Rim·Rubber	B/B	300	306.0	50	20	198	140/96	100/56	11	2,650
	RKH-150	Aluminum Rim·Urethane	B/B	500	510.0							2,760
	RFKH-150	Steel Rim·Urethane	B/B									2,820
	RRKH-150	Aluminum Rim·MC Nylon	B/B	550	561.0							2,760
	UWBKH-150	MC Nylon	B/B									2,620
200	RGKH-200	Steel Rim·Rubber	B/B	410	418.2	63	25	250	151/102	112/63	14	4,820
	RFKH-200	Steel Rim·Urethane	B/B	600	612.0							4,830
	RRKH-200	Aluminum Rim·MC Nylon	B/B									660
	UWBKH-200	MC Nylon	B/B	4,200								
												42

Bearing: B/B -- Steel bearing

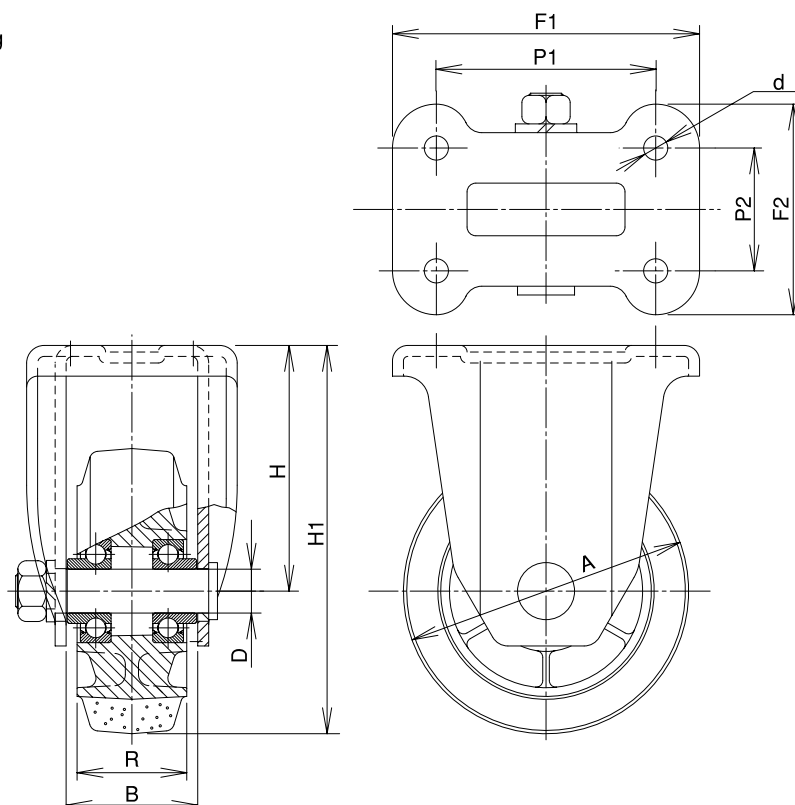

JMB Type

Size: 100mm~130mm

Heavy Duty Swivel Bracket with Stopper

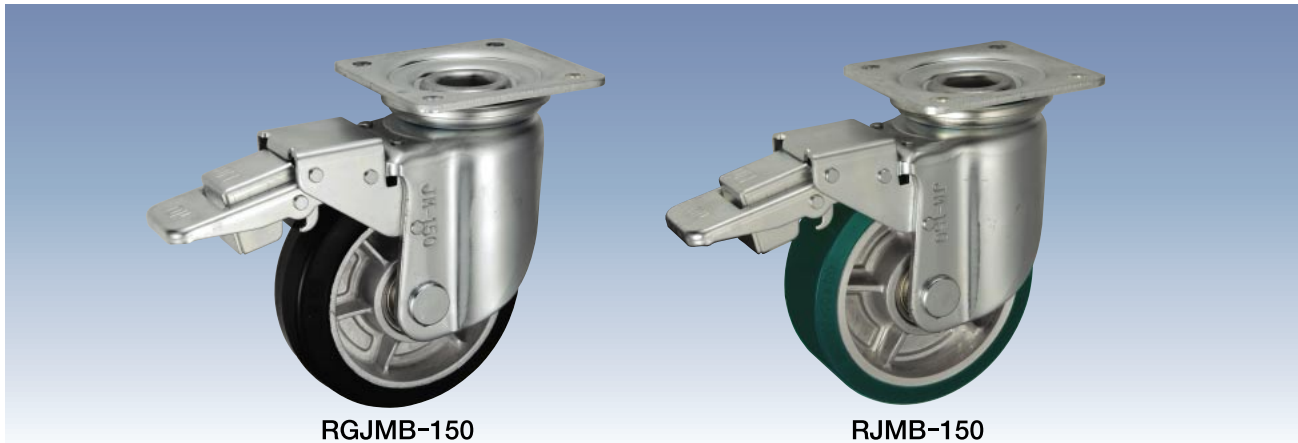

RGJMB-150

RJMB-150

Unit: mm

Size 	Model Number	Wheel	Bearing	Load Capacity		Tire Width R 	Shaft Diameter D 	Overall Height H1 	Plate Size F1/F2 	Mounting Hole Spacing P1/P2 	Plate Hole d 	Offset E 	Weight (g) 	
				(daN)	(kgf)									
100	RGNJMB-100	Reinforced Nylon	B/B	460	469.2	45	12	144	108/108	80/80	11	37	2,250	
	RGJMB-100	Aluminum Rim·Rubber	B/B	200	204.0	2,280								
	RJMB-100	Aluminum Rim·Urethane	B/B	300	306.0	50							2,280	
	RFJMB-100	Steel Rim·Urethane	B/B	460	469.2	45							2,290	
	RRJMB-100	MC Nylon	B/B	460	469.2	29							2,190	
	UWBJMB-100	MC Nylon	B/B	460	469.2	29							2,130	
130	RGJMB-130	Aluminum Rim·Rubber	B/B	240	244.8	50	20	177	108/108	80/80	11	40	3,310	
	RJMB-130	Aluminum Rim·Urethane	B/B	450	459.0								3,450	
	RFJMB-130	Steel Rim·Urethane	B/B	450	459.0								3,480	
	RRJMB-130	Aluminum Rim·MC Nylon	B/B	500	510.0								3,460	
	UWBJMB-130	MC Nylon	B/B	500	510.0								36	3,210

Bearing: B/B -- Steel bearing

The stopper of the JMB Type bracket can lock the wheel to stop the caster.

[Bracket Dimensions]

Unit: mm

Size 	Load Capacity		Bracket Height H 	Bracket Width B 	Weight (g)
	(daN)	(kgf)			
100	460	469.2	94	57	1,750
130	500	510.0	112	60	2,400
150	550	561.0	123	60	2,980
200	660	673.2	150	71	4,690

[Pedal Dimensions]

Unit: mm

Size 	Pedal Rod K 	Stop Torque (kg-cm)
100	150	130
130	180	200
150	190	250
200	250	300

* The shaft set is included in the bracket.

JMB Type

Size: 150mm~200mm
Heavy Duty Swivel Bracket with Stopper

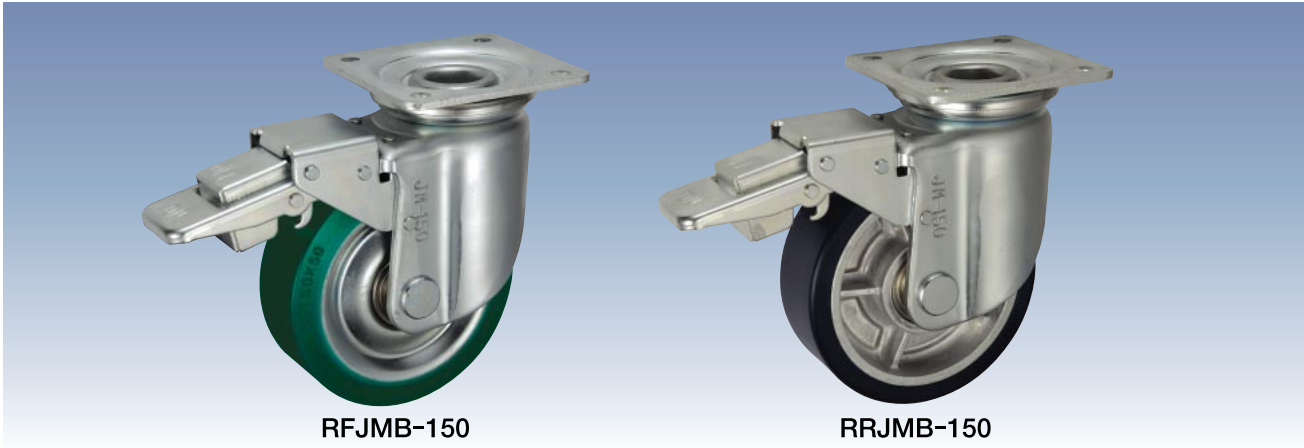

RFJMB-150

RRJMB-150

Unit: mm

Size 	Model Number	Wheel	Bearing	Load Capacity		Tire Width R	Shaft Diameter D	Overall Height H1	Plate Size F1/F2	Mounting Hole Spacing P1/P2	Plate Hole d	Offset E	Weight (g)
				(daN)	(kgf)								
150	RGJMB-150	Aluminum Rim·Rubber	B/B	300	306.0	50	20	198	120/120	90/90	11	45	4,110
	RJMB-150	Aluminum Rim·Urethane	B/B	500	510.0								4,220
	RFJMB-150	Steel Rim·Urethane	B/B	500	510.0								4,280
	RRJMB-150	Aluminum Rim·MC Nylon	B/B	550	561.0								4,220
	UWBJMB-150	MC Nylon	B/B	550	561.0								4,080
200	RGJMB-200	Steel Rim·Rubber	B/B	410	418.2	63	25	250	140/140	112/112	14	58	7,250
	RFJMB-200	Steel Rim·Urethane	B/B	600	612.0								7,260
	RRJMB-200	Aluminum Rim·MC Nylon	B/B	660	673.2								7,100
	UWBJMB-200	MC Nylon	B/B	660	673.2								6,630

Bearing: B/B -- Steel bearing

The stopper of the JMB Type bracket can lock the wheel to stop the caster.

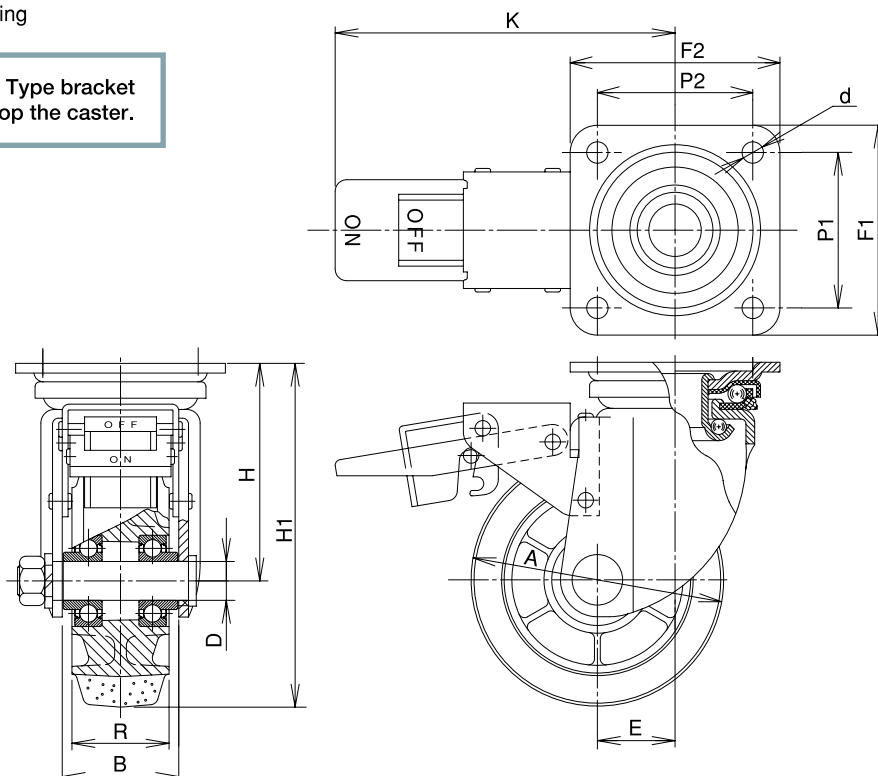

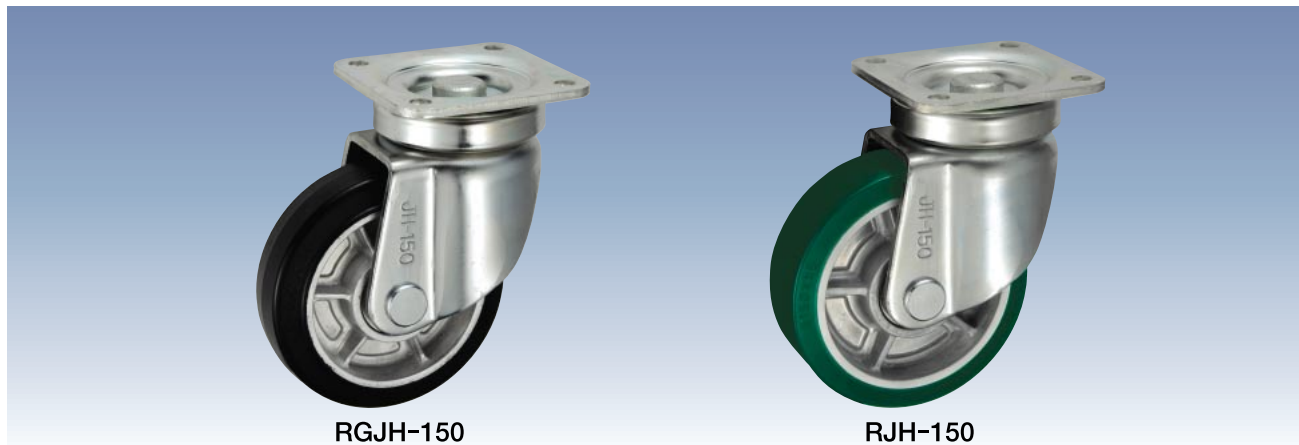

RGJH-150

RJH-150

Unit: mm

Size 	Model Number	Wheel	Bearing	Load Capacity		Tire Width R 	Shaft Diameter D 	Overall Height H1 	Plate Size F1/F2 	Mounting Hole Spacing P1/P2 	Plate Hole d 	Offset E 	Weight (g)
				(daN)	(kgf)								
130	RGJH-130	Aluminum Rim·Rubber	B/B	240	244.8	50	20	177	108/108	80/80	11	45	3,300
	RJH-130	Aluminum Rim·Urethane	B/B	450	459.0								3,440
	RFJH-130	Steel Rim·Urethane	B/B	500	510.0								3,470
	RRJH-130	Aluminum Rim·MC Nylon	B/B	550	561.0								3,450
	UWBJH-130	MC Nylon	B/B	600	612.0								3,200
150	RGJH-150	Aluminum Rim·Rubber	B/B	300	306.0	50	20	198	120/120	90/90	11	50	4,070
	RJH-150	Aluminum Rim·Urethane	B/B	500	510.0								4,180
	RFJH-150	Steel Rim·Urethane	B/B	550	561.0								4,240
	RRJH-150	Aluminum Rim·MC Nylon	B/B	600	612.0								4,180
	UWBJH-150	MC Nylon	B/B	600	612.0								4,040

Bearing: B/B -- Steel bearing

Include Thrust ball and Taper roller bearing!

[Bracket Dimensions]

Unit: mm

Size 	Load Capacity		Bracket Height H 	Bracket Width B 	Weight (g)
	(daN)	(kgf)			
130	550	561.0	112	60	2,390
150	600	612.0	123	60	2,940
200	■ JH-200 Shaft Diameter 25				
	800	816.0	150	71	3,460
	■ JH-200 Shaft Diameter 20				
	800	816.0	150	56	3,270

* The shaft set is included in the bracket.

Distinctive Features

The swivel part includes a thrust ball bearing in the upper part and a taper roller bearing in the lower part. This design was embodied, for stabilizing the smooth swivel function and abrasion resistance under heavy loading for a long period of time.

JH Type

Size: 200mm

Super Heavy Duty Swivel Bracket



RFJH-150

RRJH-150

Size 	Model Number	Wheel	Bearing	Load Capacity		Tire Width R	Shaft Diameter D	Overall Height H1	Plate Size F1/F2	Mounting Hole Spacing P1/P2	Plate Hole d	Offset E	Weight (g)
				(daN)	(kgf)								
200	■ JH-200 Shaft Diameter 25												
	RGJH-200	Steel Rim · Rubber	B/B	410	418.2	63	25	250	140/140	112/112	14	70	6,020
	RFJH-200	Steel Rim · Urethane	B/B	600	612.0								6,030
	RRJH-200	Aluminum Rim · MC Nylon	B/B	660	673.2								5,870
	UWBJH-200	MC Nylon	B/B	800	816.0	42	5,400						
	■ JH-200 Shaft Diameter 20												
SVJH-200	Rubber	B/B	250	255.0	45	20	250	140/140	112/112	14	70	5,020	
SHVJH-200	High-Rebound	B/B	250	255.0								5,020	

Unit: mm

Bearing: B/B -- Steel bearing

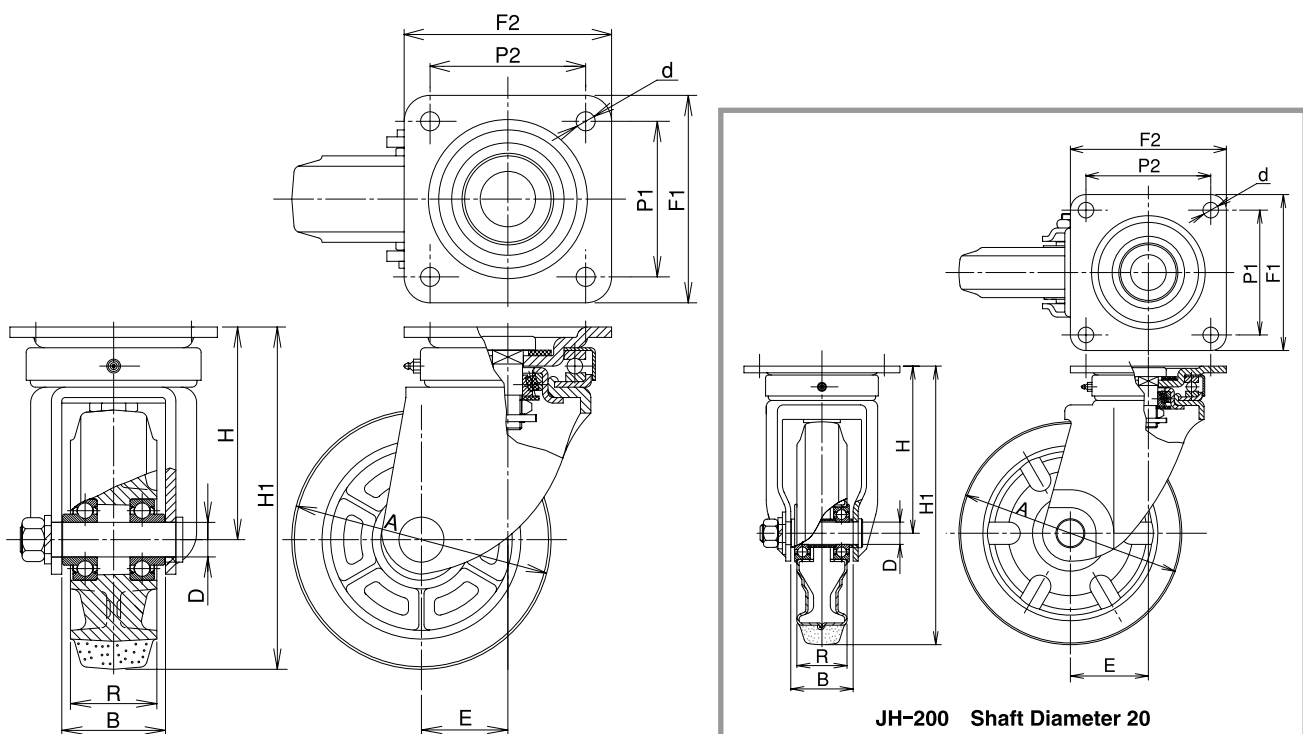

JH-200 Shaft Diameter 20

JHB Type

Size: 150mm

Super Heavy Duty Swivel Bracket with Stopper

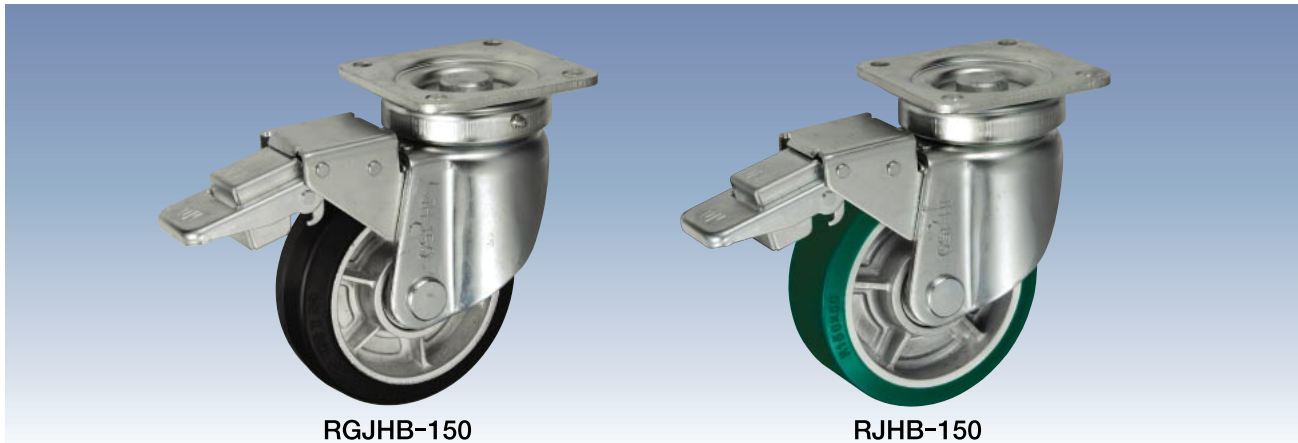

RGJHB-150

RJHB-150

Unit: mm

Size A	Model Number	Wheel	Bearing	Load Capacity		Tire Width R	Shaft Diameter D	Overall Height H1	Plate Size F1/F2	Mounting Hole Spacing P1/P2	Plate Hole d	Offset E	Weight (g)
				(daN)	(kgf)								
150	RGJHB-150	Aluminum Rim · Rubber	B/B	300	306.0	50	20	198	120/120	90/90	11	50	4,610
	RJHB-150	Aluminum Rim · Urethane	B/B	500	510.0								4,720
	RFJHB-150	Steel Rim · Urethane	B/B	550	561.0								4,780
	RRJHB-150	Aluminum Rim · MC Nylon	B/B	550	561.0								4,720
	UWBJHB-150	MC Nylon	B/B	600	612.0	40	4,580						

Bearing: B/B -- Steel bearing

Include Thrust ball and Taper roller bearing!

Distinctive Features

The swivel part includes a thrust ball bearing in the upper part and a taper roller bearing in the lower part. This design was embodied, for stabilizing the smooth swivel function and abrasion resistance under heavy loading for a long period of time.

The stopper of the JHB Type bracket can lock the wheel to stop the caster.

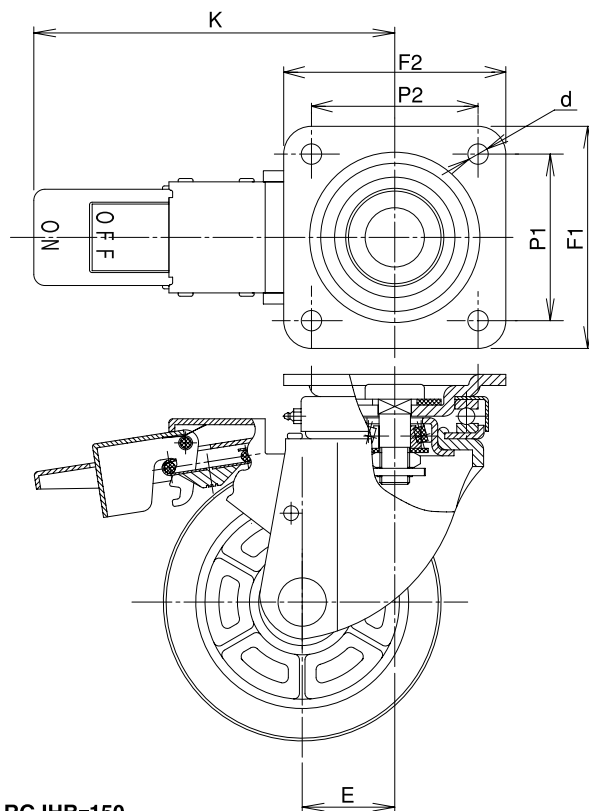
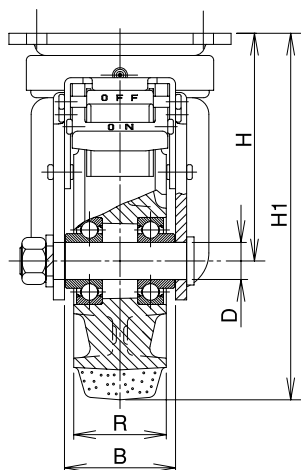

RGJHB-150

JHB Type

Size: 150mm

Super Heavy Duty Swivel Bracket with Stopper

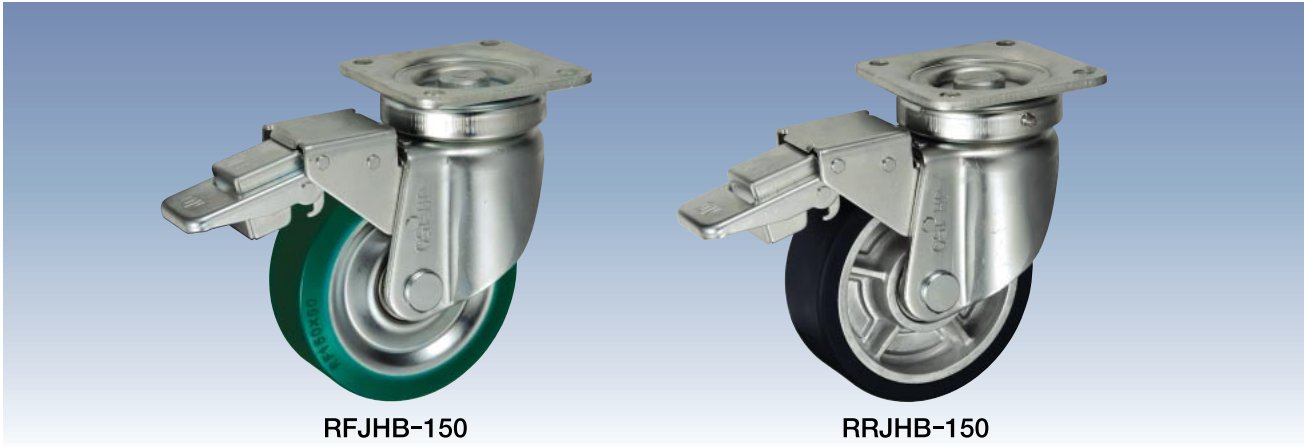

RFJHB-150

RRJHB-150

[Bracket Dimensions]

Unit: mm

Size	Load Capacity		Bracket Height H	Bracket Width B	Weight (g)
	(daN)	(kgf)			
150	600	612.0	123	60	3,480

[Pedal Dimensions]

Unit: mm

Size	Pedal Rod K	Stop Torque (kg-cm)
150	195	250

* The shaft set is included in the bracket.

Heavy Duty Caster Series

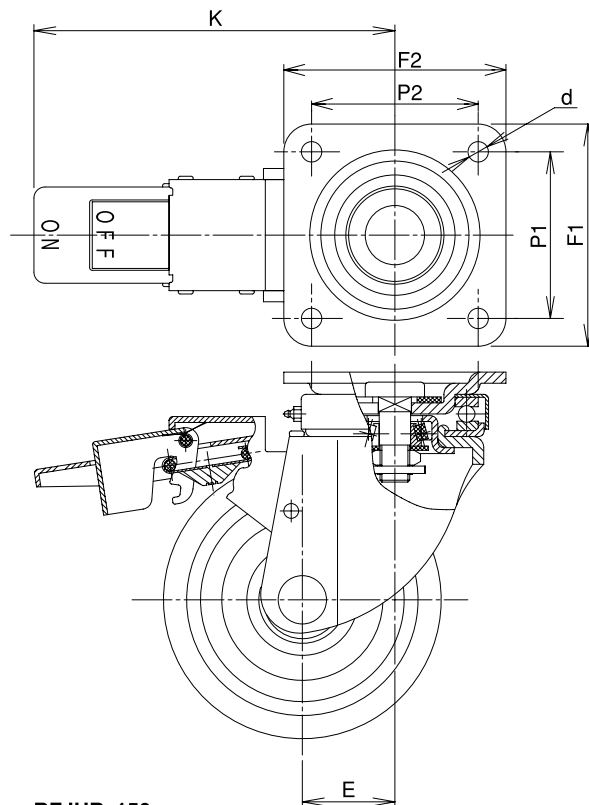
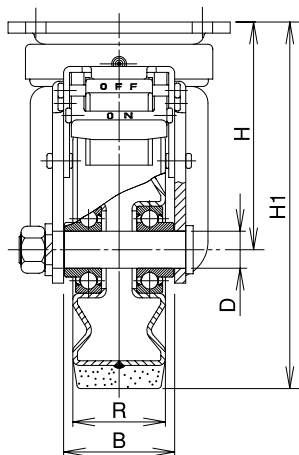

RFJHB-150

JHW Type

Size: 150mm~200mm

Towing Swivel Bracket

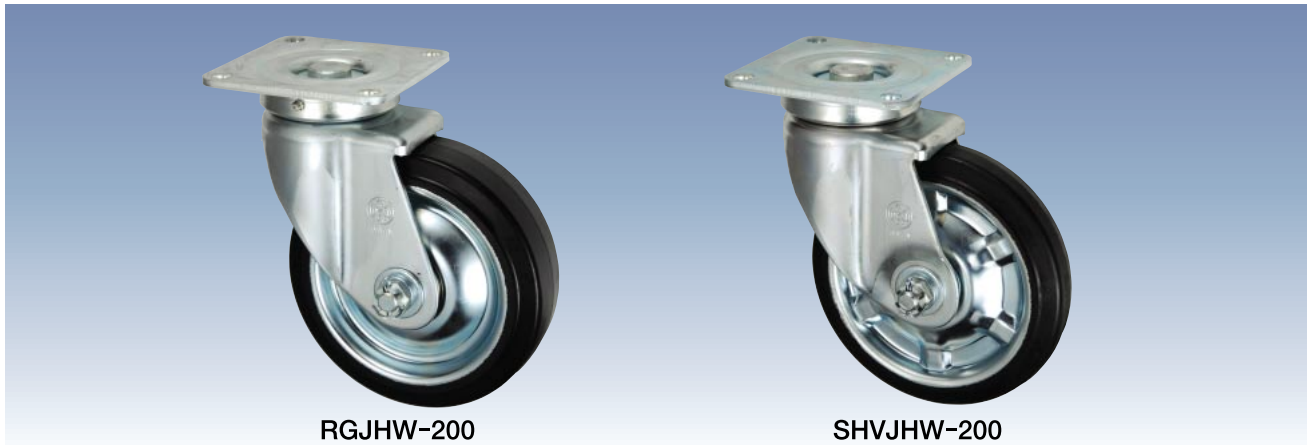

RGJHW-200

SHVJHW-200

Unit: mm

Size 	Model Number	Wheel	Bearing	Load Capacity		Tire Width R	Shaft Diameter D	Overall Height H1	Plate Size F1/F2	Mounting Hole Spacing P1/P2	Plate Hole d	Offset E	Weight (g)
				(daN)	(kgf)								
150	RGJHW-150	Aluminum Rim·Rubber	B/B	300	306.0	50	20	198	120/120	90/90	11	50	4,070
	RJHW-150	Aluminum Rim·Urethane	B/B	500	510.0								4,180
	RFJHW-150	Steel Rim·Urethane	B/B										4,240
200	■JHW-200 Shaft Diameter 25												
	RGJHW-200	Steel Rim·Rubber	B/B	410	418.2	63	25	250	140/140	112/112	14	70	6,010
	RFJHW-200	Steel Rim·Urethane	B/B	600	612.0								6,020
	■JHW-200 Shaft Diameter 20												
	SVJHW-200	Rubber	B/B	250	255.0	45	20	250	140/140	112/112	14	70	5,020
	SHVJHW-200	High-Rebound	B/B										5,020

Bearing: B/B -- Steel bearing

The shaft includes a split pin for preventing loosening.

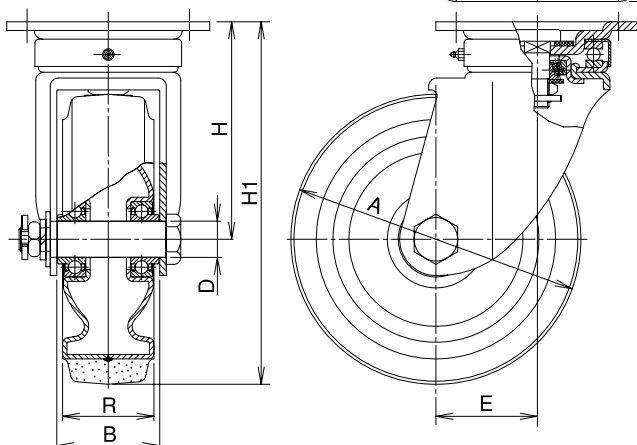
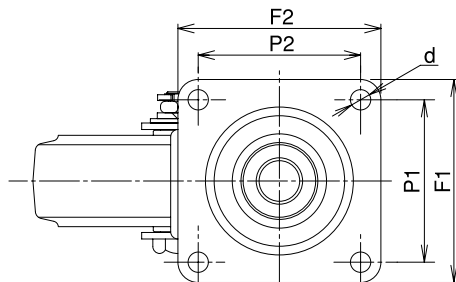

[Bracket Dimensions]

Unit: mm

Size 	Load Capacity		Bracket Height H	Bracket Width B	Weight (g)
	(daN)	(kgf)			
150	600	612.0	123	60	2,940
200	■JHW-200 Shaft Diameter 25				
	800	816.0	150	71	3,450
	■JHW-200 Shaft Diameter 20				
	800	816.0	150	56	3,270

* The shaft set is included in the bracket.

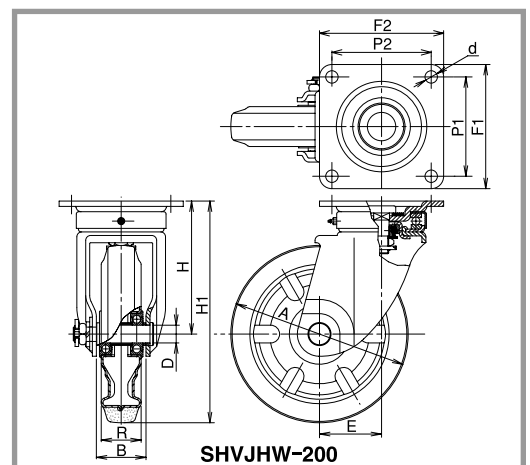

SHVJHW-200

KHW/KW Type

Size: 150mm~200mm

Towing Rigid Bracket

RGKHW-200

SHVKW-200

Unit: mm

Size 	Model Number	Wheel	Bearing	Load Capacity		Tire Width R	Shaft Diameter D	Overall Height H1	Plate Size F1/F2	Mounting Hole Spacing P1/P2	Plate Hole d	Weight (g)	
				(daN)	(kgf)								
150	RGKHW-150	Aluminum Rim · Rubber	B/B	300	306.0	50	20	198	140/96	100/56	11	2,650	
	RKHW-150	Aluminum Rim · Urethane	B/B	500	510.0							2,760	
	RFKHW-150	Steel Rim · Urethane	B/B									2,820	
200	■ KHW-200 Shaft Diameter 25												
	RGKHW-200	Steel Rim · Rubber	B/B	410	418.2	63	25	250	151/102	112/63	14	4,810	
	RFKHW-200	Steel Rim · Urethane	B/B	600	612.0							4,820	
	■ KW-200 Shaft Diameter 20												
	SVKW-200	Rubber	B/B	250	255.0	45	20	250	151/102	112/63	11	3,500	
	SHVKW-200	High-Rebound	B/B									3,500	

Bearing: B/B -- Steel bearing

The shaft includes a split pin for preventing loosening.

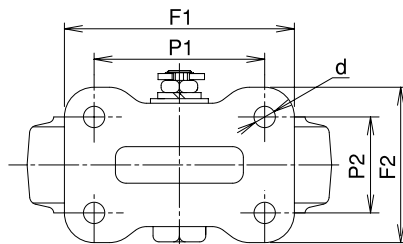
【Bracket Dimensions】

Unit: mm

Size 	Load Capacity		Bracket Height H	Bracket Width B	Weight (g)
	(daN)	(kgf)			
150	550	561.0	123	60	1,520
200	■ KHW-200 Shaft Diameter 25				
	660	673.2	150	71	2,250
	■ KW-200 Shaft Diameter 20				
	420	428.4	150	56	1,750

* The shaft set is included in the bracket.

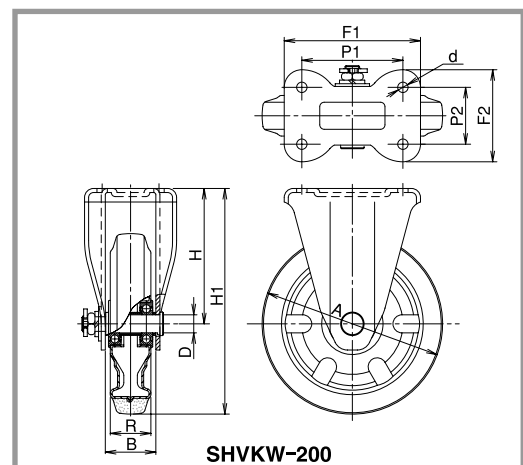
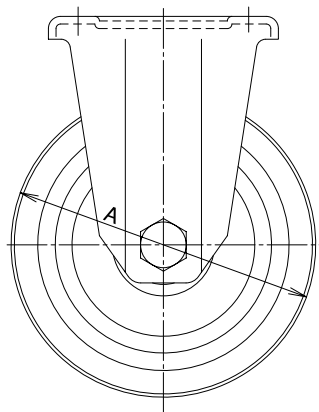
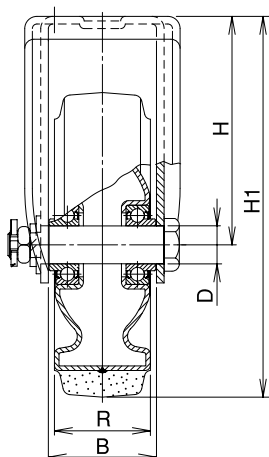

SHVKW-200

Low Height Caster Series

T Type

Size: 50mm

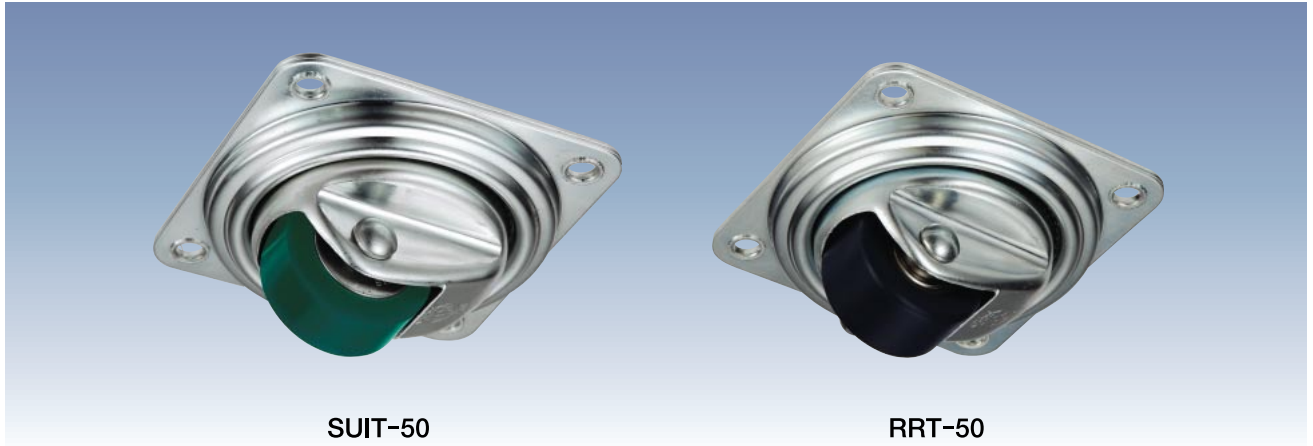







Low Height Swivel Bracket



SUIT-50

RRT-50





Unit: mm

Size 	Model Number	Wheel	Bearing	Load Capacity		Tire Width R 	Shaft Diameter D 	Overall Height H1 	Plate Size F1/F2 	Mounting Hole Spacing P1/P2 	Plate Hole d 	Offset E 	Weight (g) 
				(daN)	(kgf)								
50	SUIT-50	Urethane	B/B	80	81.6	24	10	57	118/118	94/94	8.5	12	800
	RRT-50	MC Nylon	B/B	100	102.0	27							780
	FT-50	Steel	B/B	60	61.2								990
	FAT-50	Steel											1,060

Bearing: No mark -- Spindle sleeve, B/B -- Steel bearing

[Bracket Dimensions]

Unit: mm

Size 	Load Capacity		Bracket Height H 	Bracket Width B 	Weight (g) 
	(daN)	(kgf)			
50	100	102.0	32	32	670

* The shaft set is included in the bracket.

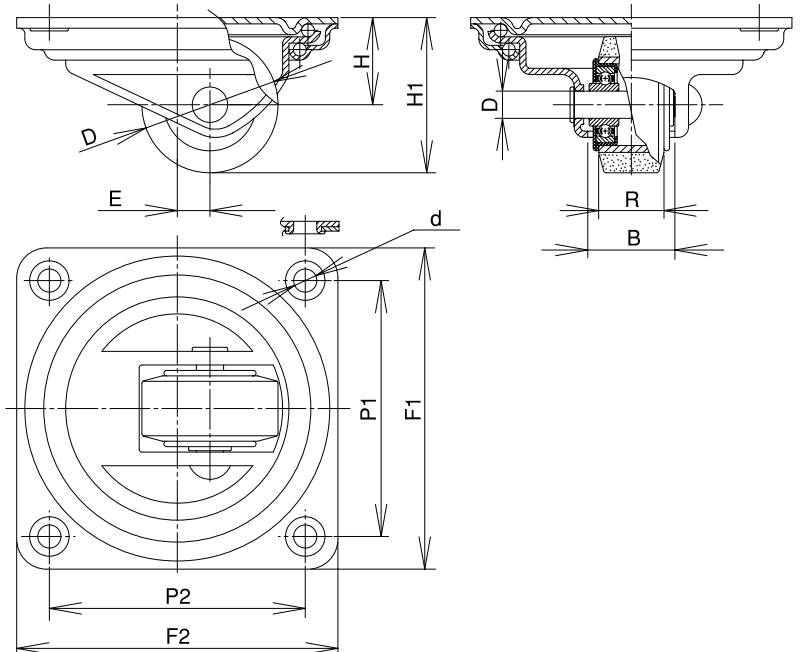

TN Type

Size: 50mm

Dust-Proof Low Height Swivel Bracket

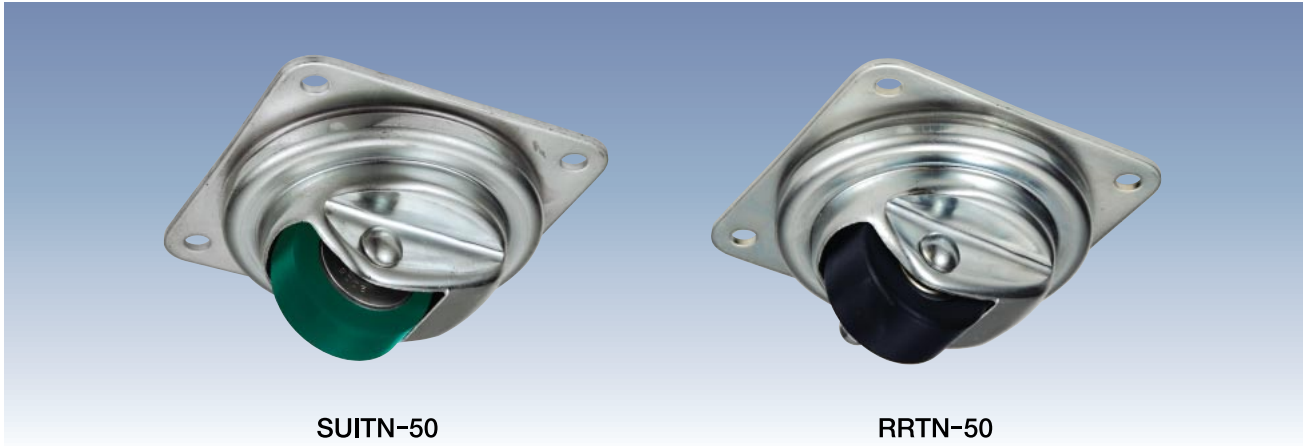

SUTN-50

RRTN-50

Size 	Model Number	Wheel	Bearing	Load Capacity		Tire Width R	Shaft Diameter D	Overall Height H1	Plate Size F1/F2	Mounting Hole Spacing P1/P2	Plate Hole d	Offset E	Weight (g)
				(daN)	(kgf)								
50 	SUTN-50	Urethane	B/B	80	81.6	24	10	63	118/118	94/94	8.5	13	850
	RRTN-50	MC Nylon	B/B	100	102.0	27							830
	FTN-50	Steel	B/B										1,040
	FATN-50	Steel		60	61.2								1,110

Unit: mm

Bearing: No mark -- Spindle sleeve, B/B -- Steel bearing

[Bracket Dimensions]

Unit: mm

Size 	Load Capacity		Bracket Height H	Bracket Width B	Weight (g)
	(daN)	(kgf)			
50 	100	102.0	38	32	720

* The shaft set is included in the bracket.

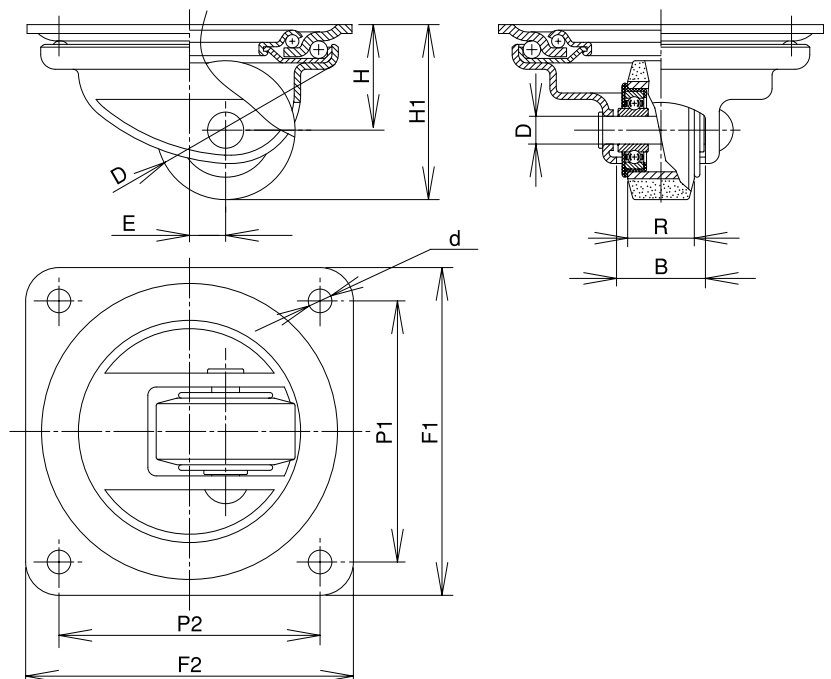

Low Height Caster Series

TH Type

Size: 50mm~65mm

Heavy Duty Low Height Swivel Bracket

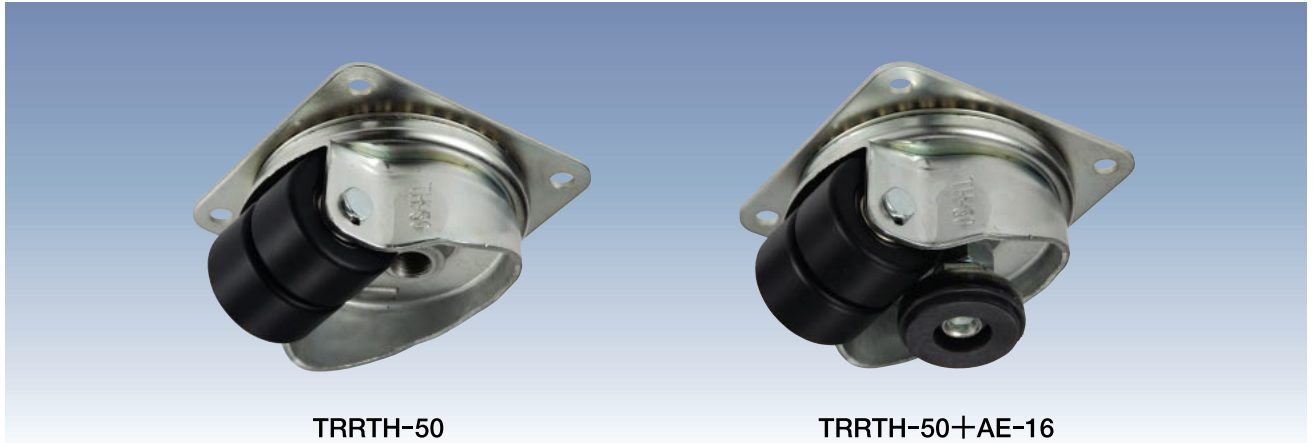

TRRTH-50

TRRTH-50+AE-16

Size 	Model Number	Wheel	Bearing	Load Capacity		Tire Width R	Shaft Diameter D	Overall Height H1	Plate Size F1/F2	Mounting Hole Spacing P1/P2	Plate Hole d	Offset E	Adjuster ※	Weight (g)	
				(daN)	(kgf)										
50	TSUITH-50	Urethane	B/B	150	153.0	20.5	10	70	118/118	94/94	8.5	40	AE-16	1,330	
	TRRTH-50	MC Nylon	B/B	350	357.0	27								1,270	
	TFTH-50	Steel	B/B											1,690	
65	TSUITH-65	Urethane	B/B	250	255.0	25	12	87	118/118	94/94	8.5	45	AE-20	1,760	
	TRRTH-65	MC Nylon	B/B	450	459.0										1,440
	TFTH-65	Steel	B/B												2,240

Unit: mm

Bearing: B/B -- Steel bearing

The wheel is used in two wheels.

※The adjuster is optional (Page 82).

[Bracket Dimensions]

Size 	Load Capacity		Bracket Height H	Bracket Width B	Weight (g)
	(daN)	(kgf)			
50	400	408.0	45	60	1,050
65	500	510.0	54	60	1,140

Unit: mm

* The shaft set is included in the bracket.

[Adjuster Dimensions]

Compatible Adjuster	Adjustment a		
	Max. Height Hmax	Min. Height Hmin	Adjustment a
AE-16	80	65	15
AE-20	94	79	15

Unit: mm

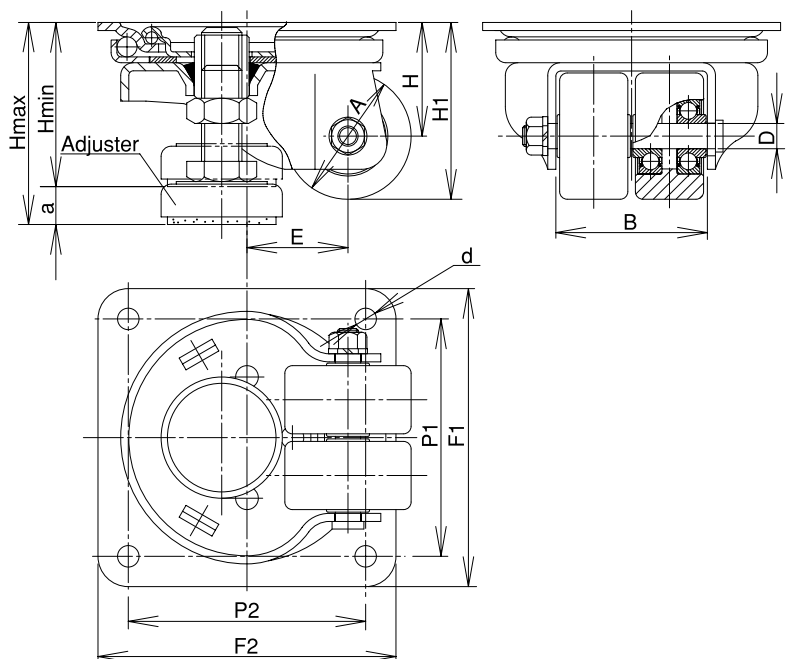

AE Type

Adjuster



Unit: mm

Model Number	Load Capacity		Bolt Diameter P	Bolt Length		Foot Diameter ϕN	Lock Nut		Weight (g)	Compatible Caster
	(daN)	(kgf)		L1	L2		s	m		
AE-16	500	510.0	M16×P2	38	63	48	24	10	190	TH-50
AE-20	600	612.0	M20×P2.5	45	72	48	30	12	270	TH-65

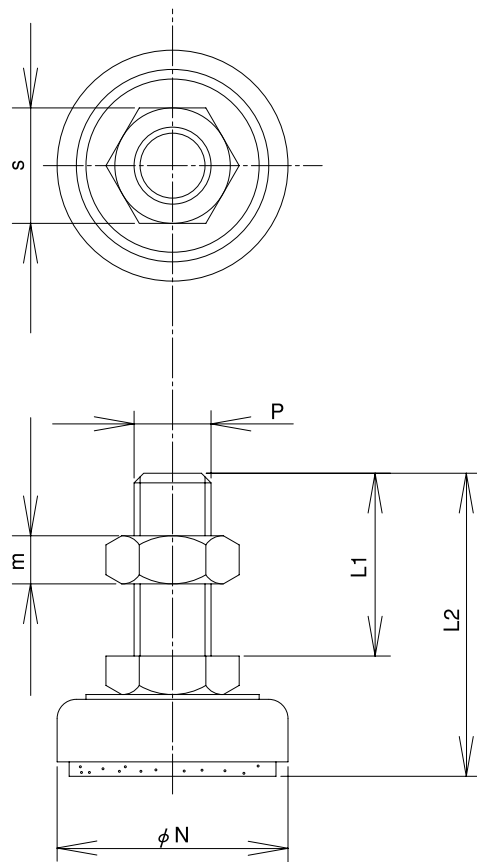



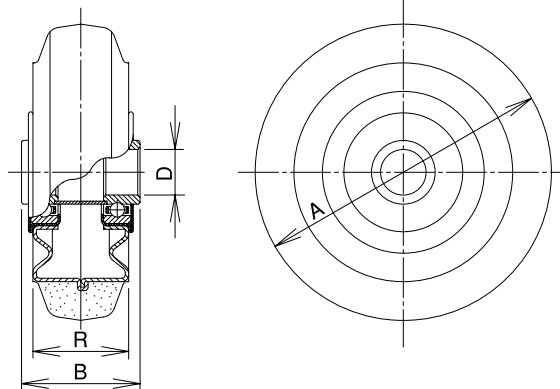

S/SR_{Type}

Wheel

S Type Steel Rim · Polybutadiene Rubber Wheel



Unit: mm



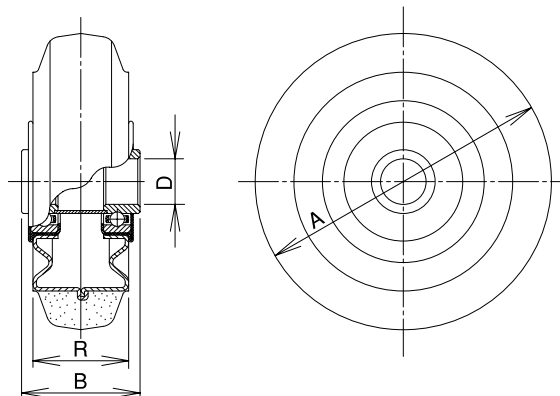
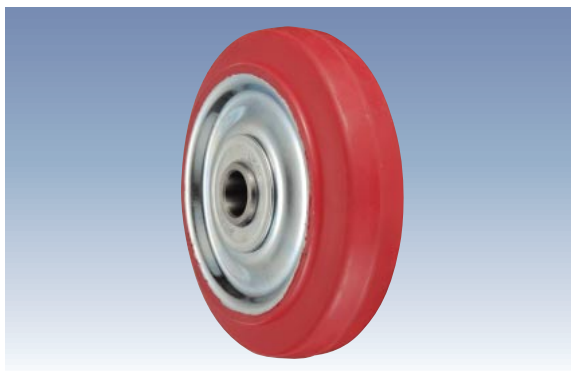

Size 	Model Number	Load Capacity		Boss Width B 	Tire Width R 	Shaft Diameter D 	Steel Ball Bearing	Weight (g) 	Compatible Caster Bracket
		(daN)	(kgf)						
75	S-75	80	81.6	39	32	10	200B	200	J, JA K, KA JB, JAB KBZ, KABZ
100	S-100	130	132.6	42	35	12	201B	360	
130	S-130	180	183.6	52	42	20	204B	780	
150	S-150	200	204.0	55	45	20	204B	960	
200	S-200	250	255.0	55	45	20	204B	1,670	
250	S-250	330	336.6	64	50	25	205B	2,520	J, K, JB
300	S-300	350	357.0	71	50	25	205B	4,770	J, K

Wheel Rim: Steel

SR Type Steel Rim · Polybutadiene Red Rubber Wheel



Unit: mm

Size 	Model Number	Load Capacity		Boss Width B 	Tire Width R 	Shaft Diameter D 	Steel Ball Bearing	Weight (g) 	Compatible Caster Bracket
		(daN)	(kgf)						
75	SR-75	60	61.2	39	32	10	200B	200	J, JA K, KA JB, JAB KBZ, KABZ
100	SR-100	100	102.0	42	35	12	201B	360	
130	SR-130	140	142.8	52	42	20	204B	780	
150	SR-150	160	163.2	55	45	20	204B	960	
200	SR-200	200	204.0	55	45	20	204B	1,670	
250	SR-250	260	265.2	64	50	25	205B	2,250	J, K, JB

Wheel Rim: Steel

SH/CR_{Type}

Wheel

SH Type Steel Rim · Polybutadiene High-Rebound Rubber Wheel

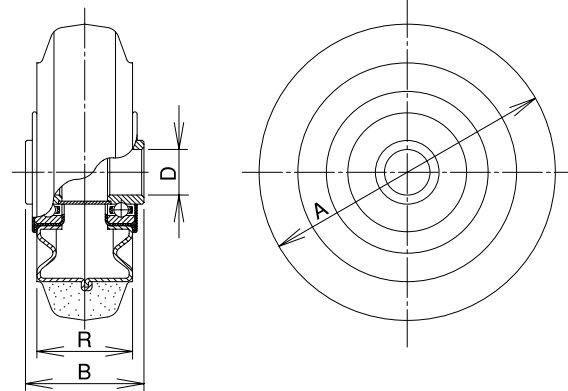

Unit: mm

Size 	Model Number	Load Capacity		Boss Width B 	Tire Width R 	Shaft Diameter D 	Steel Ball Bearing	Weight (g) 	Compatible Caster Bracket
		(daN)	(kgf)						
200	SH-200	250	255.0	55	45	20	204B	1,670	J, JA K, KA JB, JAB KBZ, KABZ

Wheel Rim: Steel

CR Type Steel Rim · Chloroprene Heat-resistance Rubber Wheel

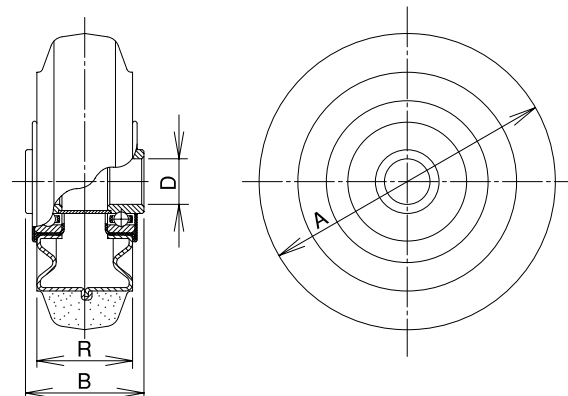

Unit: mm

Size 	Model Number	Load Capacity		Boss Width B 	Tire Width R 	Shaft Diameter D 	Steel Ball Bearing	Weight (g) 	Compatible Caster Bracket
		(daN)	(kgf)						
75	CR-75	80	81.6	39	32	10	200B	220	J, JA K, KA JB, JAB KBZ, KABZ
100	CR-100	130	132.6	42	35	12	201B	390	
130	CR-130	180	183.6	52	42	20	204B	810	
150	CR-150	200	204.0	55	45	20	204B	1,000	
200	CR-200	250	255.0	55	45	20	204B	1,750	
250	CR-250	330	336.6	64	50	25	205B	2,740	J, K, JB

Wheel Rim: Steel



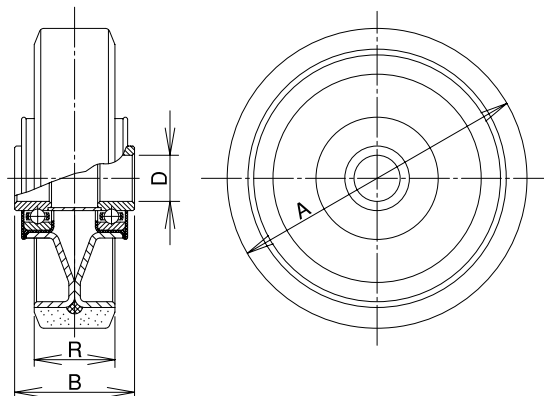
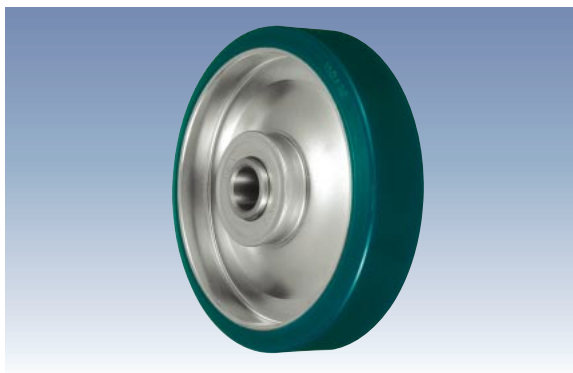

SUI/SUIE Type

Wheel

SUI Type Steel Rim · Urethane Rubber Wheel



Unit: mm

Size 	Model Number	Load Capacity		Boss Width B 	Tire Width R 	Shaft Diameter D 	Steel Ball Bearing	Weight (g) 	Compatible Caster Bracket
		(daN)	(kgf)						
50	SUI-50	80	81.6	28	20.5	10	200B	140	TH, JM, KH
65	TSUI-65	100	102.0	30	25	12	6201ZZY	310	TH
75	SUI-75	120	122.4	39	32	10	200B	280	J, JA K, KA JB, JAB KBZ, KABZ
100	SUI-100	180	183.6	42	32	12	201B	430	
130	SUI-130	250	255.0	52	35	20	204B	910	
150	SUI-150	300	306.0	55	38	20	204B	1,150	
200	SUI-200	400	408.0	55	42	20	204B	1,840	
250	SUI-250	500	510.0	64	45	25	205B	3,080	J, K, JB
300	SUI-300	600	612.0	71	50	25	205B	4,440	J, K

Wheel Rim: Steel

SUIE Type Steel Rim · Anti-Static Urethane Rubber Wheel



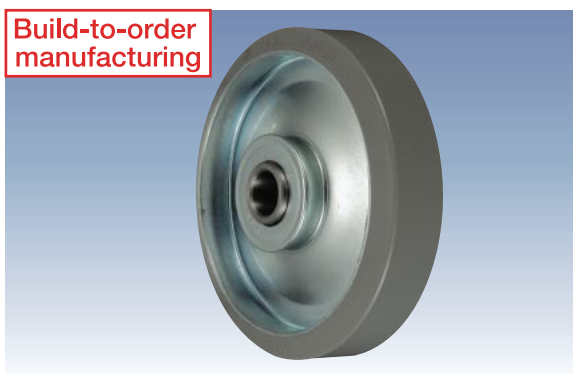

Build-to-order manufacturing

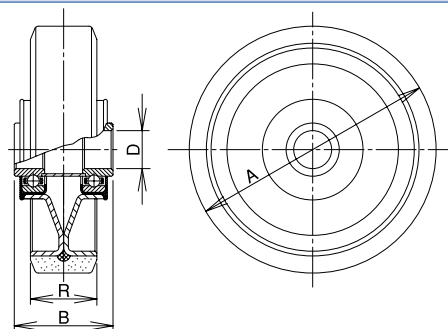

By adding semi-conducting property to urethane rubber, it became possible to prevent the accumulation of static electricity and remove static electricity gently without generating a shock.



Unit: mm

Size 	Model Number	Load Capacity		Boss Width B 	Tire Width R 	Shaft Diameter D 	Steel Ball Bearing	Weight (g) 	Compatible Caster Bracket
		(daN)	(kgf)						
75	SUIE-75	120	122.4	39	32	10	200B	280	J, JA K, KA JB, JAB KBZ, KABZ
100	SUIE-100	180	183.6	42	32	12	201B	430	
130	SUIE-130	250	255.0	52	35	20	204B	910	
150	SUIE-150	300	306.0	55	38	20	204B	1,150	
200	SUIE-200	400	408.0	55	42	20	204B	1,840	

Wheel Rim: Steel

Volume Resistivity Value: $6 \times 10^8 \Omega \cdot \text{cm}$ (Measured by insulation resistance tester)

 Build-to-order manufacturing

PN/PND Type

Wheel

PN Type Nylon Rim · Polybutadiene Rubber Wheel

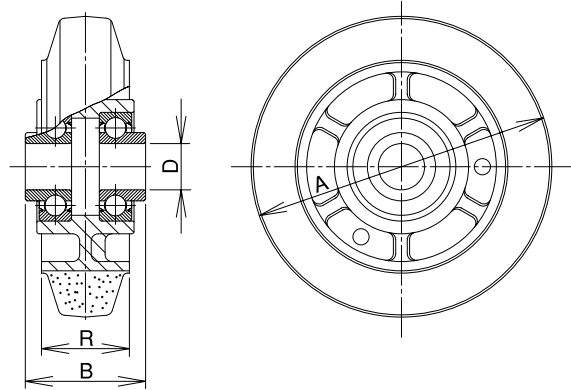

Unit: mm

Size 	Model Number	Load Capacity		Boss Width B 	Tire Width R 	Shaft Diameter D 	Steel Radial Bearing	Weight (g) 	Compatible Caster Bracket
		(daN) 	(kgf) 						
75	PN-75	70	71.4	39	32	10	6200ZZY	180	J, JA K, KA JB, JAB KBZ, KABZ
100	PN-100	100	102.0	42	32	12	6201ZZY	260	
130	PN-130	145	147.9	52	38	20	6204ZZY	580	
150	PN-150	175	178.5	55	38	20	6204ZZY	670	
200	PN-200	220	224.4	55	42	20	6204ZZY	1,020	

Wheel Rim: Nylon6

PND Type Nylon Rim · Polybutadiene Rubber Wheel (Including Stainless Steel Bearings)

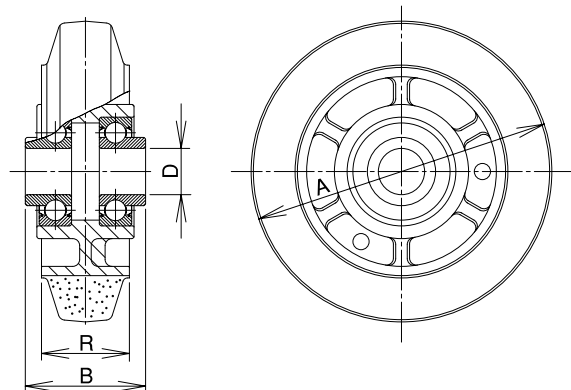

Unit: mm

Size 	Model Number	Load Capacity		Boss Width B 	Tire Width R 	Shaft Diameter D 	Stainless Steel Radial Bearing	Weight (g) 	Compatible Caster Bracket
		(daN) 	(kgf) 						
75	PND-75	70	71.4	39	32	10	SUS 6200ZZ	180	J, JA K, KA JB, JAB KBZ, KABZ
100	PND-100	100	102.0	42	32	12	SUS 6201ZZY	260	
130	PND-130	145	147.9	52	38	20	SUS 6204ZZY	580	
150	PND-150	175	178.5	55	38	20	SUS 6204ZZY	670	
200	PND-200	220	224.4	55	42	20	SUS 6204ZZY	1,020	

Wheel Rim: Nylon6



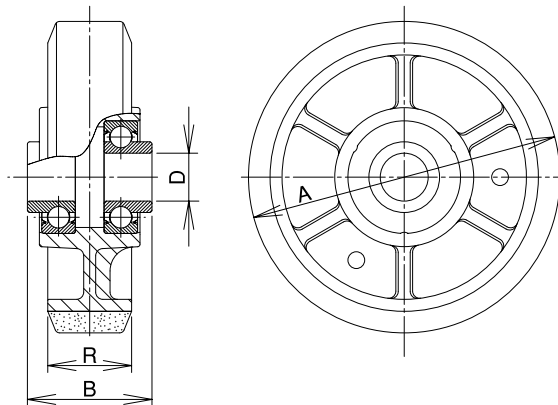
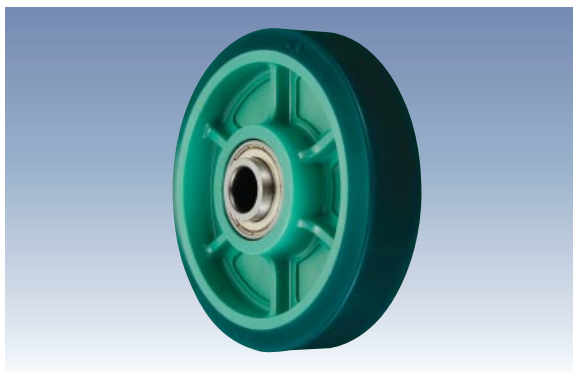

PNU/PNUD Type

Wheel

PNU Type Nylon Rim · Urethane Rubber Wheel



Unit: mm



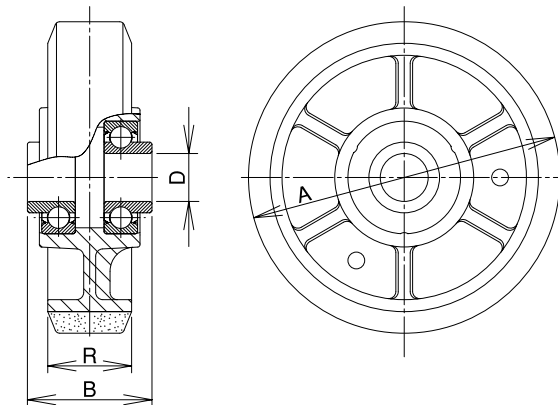
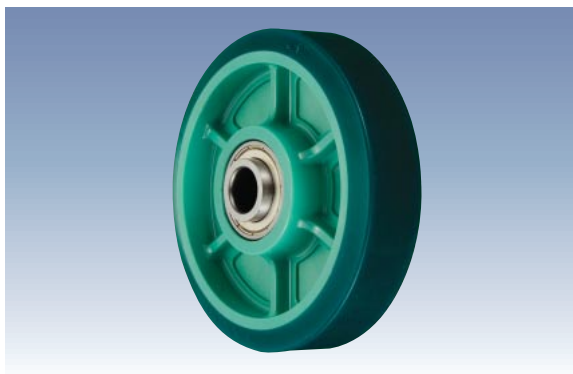

Size 	Model Number	Load Capacity		Boss Width B 	Tire Width R 	Shaft Diameter D 	Steel Radial Bearing	Weight (g) 	Compatible Caster Bracket
		(daN)	(kgf)						
75	PNU-75	100	102.0	39	32	10	6200ZZY	170	J, JA K, KA JB, JAB KBZ, KABZ
100	PNU-100	150	153.0	42	32	12	6201ZZY	240	
130	PNU-130	200	204.0	52	35	20	6204ZZY	520	
150	PNU-150	250	255.0	55	38	20	6204ZZY	630	
200	PNU-200	350	357.0	55	42	20	6204ZZY	890	

Wheel Rim: Nylon6

PNUD Type Nylon Rim · Urethane Rubber Wheel (Including Stainless Steel Bearings)



Unit: mm

Size 	Model Number	Load Capacity		Boss Width B 	Tire Width R 	Shaft Diameter D 	Stainless Steel Radial Bearing	Weight (g) 	Compatible Caster Bracket
		(daN)	(kgf)						
75	PNUD-75	100	102.0	39	32	10	SUS 6200ZZ	170	J, JA K, KA JB, JAB KBZ, KABZ
100	PNUD-100	150	153.0	42	32	12	SUS 6201ZZY	240	
130	PNUD-130	200	204.0	52	35	20	SUS 6204ZZY	520	
150	PNUD-150	250	255.0	55	38	20	SUS 6204ZZY	630	
200	PNUD-200	350	357.0	55	42	20	SUS 6204ZZY	890	

Wheel Rim: Nylon6

PNA/PNUA_{Type}

Wheel

PNA Type Nylon Rim · Rubber Wheel (Spindle Sleeve)

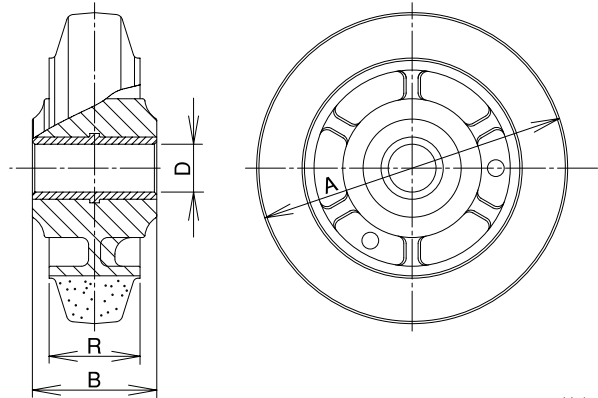

Unit: mm

Size 	Model Number	Load Capacity		Boss Width B 	Tire Width R 	Shaft Diameter D 	Bearing	Weight (g) 	Compatible Caster Bracket
		(daN)	(kgf)						
75	PNA-75	70	71.4	39	32	10	Spindle Sleeve	140	J, JA K, KA JB, JAB KBZ, KABZ
100	PNA-100	100	102.0	42	32	12		200	
130	PNA-130	120	122.4	52	38	20		390	
150	PNA-150	140	142.8	55	38	20		510	
200	PNA-200	160	163.2	55	42	20		850	

Wheel Rim: Nylon6

Spindle Sleeve: Nylon66 (Molybdenum combination)

* The wheel with a spindle sleeve may cause trudge, noise, etc. when heavily loaded.
When heavily loaded, we recommend you to use a wheel including bearings (PN / PND Type, Page 86).

PNUA Type Nylon Rim · Urethane Rubber Wheel (Spindle Sleeve)

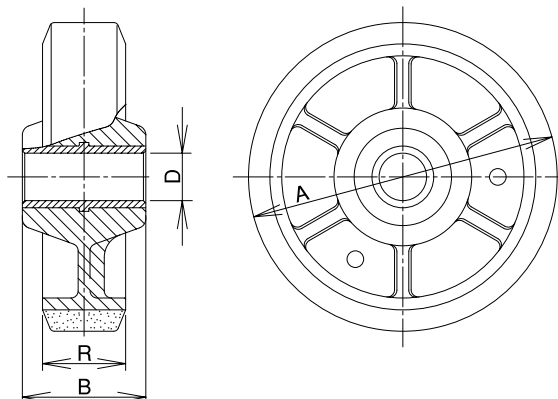

Unit: mm

Size 	Model Number	Load Capacity		Boss Width B 	Tire Width R 	Shaft Diameter D 	Bearing	Weight (g) 	Compatible Caster Bracket
		(daN)	(kgf)						
75	PNUA-75	70	71.4	39	32	10	Spindle Sleeve	120	J, JA K, KA JB, JAB KBZ, KABZ
100	PNUA-100	100	102.0	42	32	12		180	
130	PNUA-130	120	122.4	52	35	20		330	
150	PNUA-150	150	153.0	55	38	20		440	
200	PNUA-200	250	255.0	55	42	20		720	

Wheel Rim: Nylon6

Spindle Sleeve: Nylon66 (Molybdenum combination)

*The wheel with a spindle sleeve may cause trudge, noise, etc. when heavily loaded.
When heavily loaded, we recommend you to use a wheel including bearings (PNU / PNUD type, Page 87).

PB/PBD Type

Wheel

PB Type Nylon Wheel

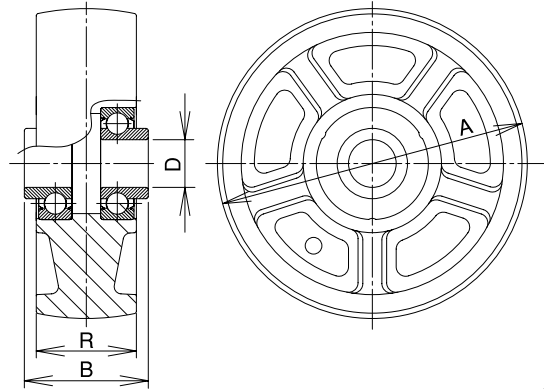
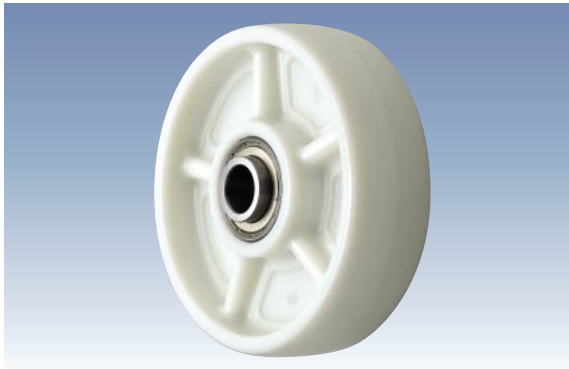

Unit: mm

Size 	Model Number	Load Capacity		Boss Width B 	Tire Width R 	Shaft Diameter D 	Steel Radial Bearing	Weight (g) 	Compatible Caster Bracket
		(daN)	(kgf)						
75	PB-75	120	122.4	39	32	10	6200ZZY	150	J, JA K, KA JB, JAB KBZ, KABZ
100	PB-100	180	183.6	42	35	12	6201ZZY	220	
130	PB-130	250	255.0	52	42	20	6204ZZY	520	
150	PB-150	300	306.0	55	45	20	6204ZZY	650	
200	PB-200	400	408.0	55	45	20	6204ZZY	950	

Wheel: Nylon6

PBD Type Nylon Wheel (Including Stainless Steel Bearings)

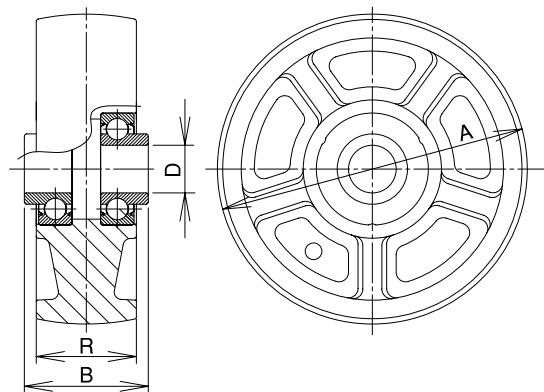
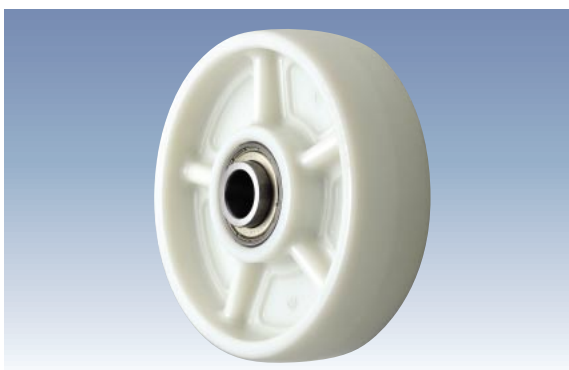

Unit: mm

Size 	Model Number	Load Capacity		Boss Width B 	Tire Width R 	Shaft Diameter D 	Stainless Steel Radial Bearing	Weight (g) 	Compatible Caster Bracket
		(daN)	(kgf)						
75	PBD-75	120	122.4	39	32	10	SUS 6200ZZ	150	J, JA K, KA JB, JAB KBZ, KABZ
100	PBD-100	180	183.6	42	35	12	SUS 6201ZZY	220	
130	PBD-130	250	255.0	52	42	20	SUS 6204ZZY	520	
150	PBD-150	300	306.0	55	45	20	SUS 6204ZZY	650	
200	PBD-200	400	408.0	55	45	20	SUS 6204ZZY	950	

Wheel: Nylon6

P/SV/SHV Type

Wheel

P Type Nylon Wheel (Spindle Sleeve)

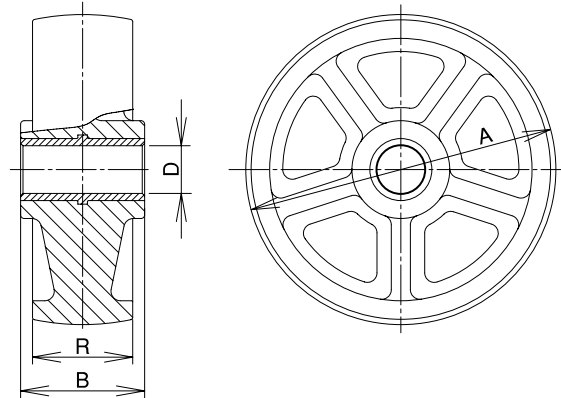

Unit: mm

Size 	Model Number	Load Capacity		Boss Width B 	Tire Width R 	Shaft Diameter D 	Bearing	Weight (g) 	Compatible Caster Bracket
		(daN)	(kgf)						
75	P-75	100	102.0	39	32	10	Spindle Sleeve	90	J, JA K, KA JB, JAB KBZ, KABZ
100	P-100	120	122.4	42	35	12		160	
130	P-130	150	153.0	52	42	20		320	
150	P-150	180	183.6	55	45	20		410	
200	P-200	250	255.0	55	45	20		740	

Wheel: Nylon6

Spindle Sleeve: Nylon66 (Molybdenum combination)

* The wheel with a spindle sleeve may cause trudge, noise, etc. when heavily loaded.
When heavily loaded, we recommend you to use a wheel including bearings (PB / PBD type, Page 89).

SV Type Steel Rim · Polybutadiene Rubber Wheel (Including Radial Bearings)

SHV Type Steel Rim · Polybutadiene High-Rebound Rubber Wheel (Including Radial Bearings)

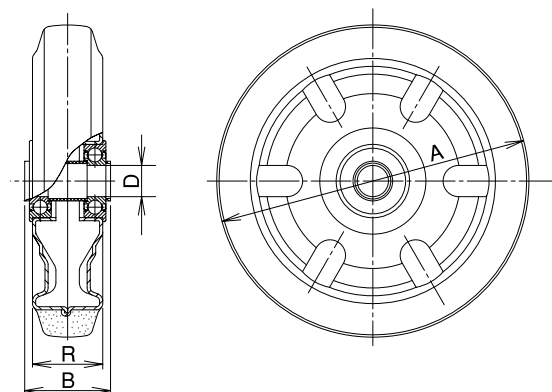

Unit: mm

Size 	Model Number	Load Capacity		Boss Width B 	Tire Width R 	Shaft Diameter D 	Steel Radial Bearing	Weight (g) 	Compatible Caster Bracket
		(daN)	(kgf)						
200	SV-200	250	255.0	55	45	20	6204ZZF	1,750	JH, JHW, KW
200	SHV-200	250	255.0	55	45	20	6204ZZF	1,750	JH, JHW, KW

Wheel Rim: Steel

RGN/RG Type



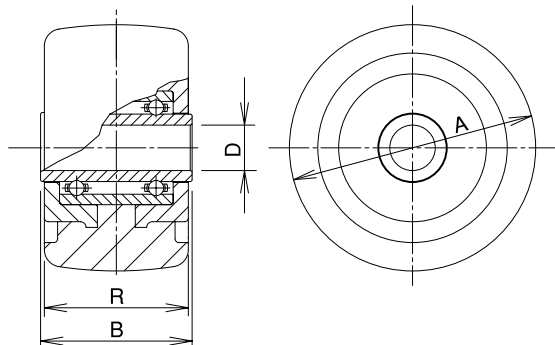

Wheel

RGN Type Heavy Duty Reinforced Nylon Wheel



RGN-100

Unit: mm

Size 	Model Number	Load Capacity		Boss Width B 	Tire Width R 	Shaft Diameter D 	Steel Ball Bearing	Weight (g) 	Compatible Caster Bracket
		(daN)	(kgf)						
50	RGN-50	200	204.0	31	28	10	1022SBW	110	JM, KH
65	RGN-65	300	306.0	40	38	12	1230SBW	220	
75	RGN-75	400	408.0	40	38	12	1230SBW	270	
100	RGN-100	500	510.0	56	45	12	1241SBW	500	JM, KH, JMB



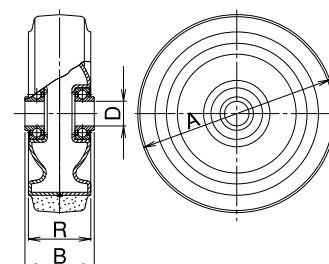
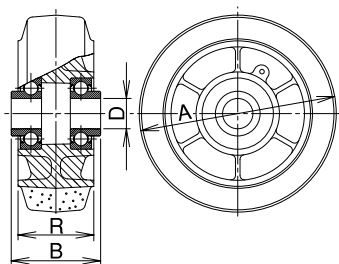

Wheel: Nylon 6 and fiberglass-mixed materials

RG Type Heavy Duty Polybutadiene Rubber Wheel



RG-200

Unit: mm

Size 	Model Number	Load Capacity		Boss Width B 	Tire Width R 	Shaft Diameter D 	Steel Radial Bearing	Weight (g) 	Compatible Caster Bracket
		(daN)	(kgf)						
100	RG-100	200	204.0	56	50	12	6201ZZY	530	JM, KH, JMB
130	RG-130	240	244.8	59	50	20	6204ZZY	910	JM, JH, KH, JMB
150	RG-150	300	306.0	59	50	20	6204ZZY	1,130	JM, JH, JHW, KH, KHW, JMB, JHB
200	RG-200	410	418.2	70	63	25	6205ZZY	2,560	JM, JH, JHW, KH, KHW, JMB

Wheel Rim: RG-100/130/150
RG-200

Aluminum alloy for die casting (ADC-12)
Steel

R/RF Type

Wheel

R Type Heavy Duty Aluminum Rim · Urethane Rubber Wheel

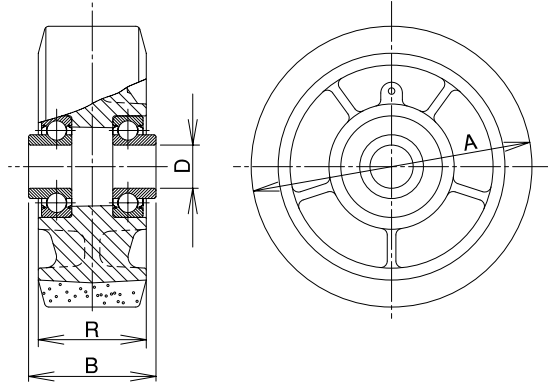
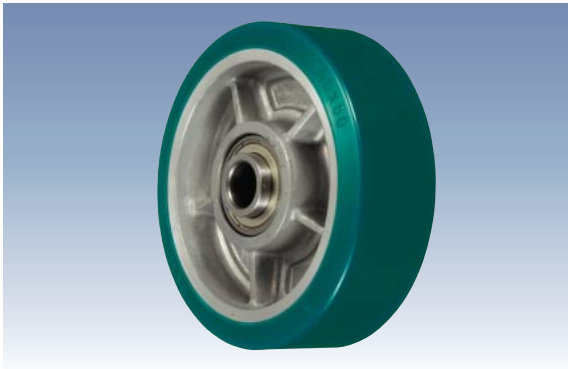

Unit: mm

Size 	Model Number	Load Capacity		Boss Width B 	Tire Width R 	Shaft Diameter D 	Steel Radial Bearing	Weight (g)	Compatible Caster Bracket
		(daN)	(kgf)						
100	R-100	300	306.0	56	50	12	6201ZZY	530	JM, KH, JMB
130	R-130	450	459.0	59	50	20	6204ZZY	1,050	JM, JH, KH, JMB
150	R-150	500	510.0	59	50	20	6204ZZY	1,240	JM, JH, JHW, KH, KHW, JMB, JHB

Wheel Rim: Aluminum alloy for die casting (ADC-12)

RF Type Heavy Duty Steel Rim · Urethane Rubber Wheel

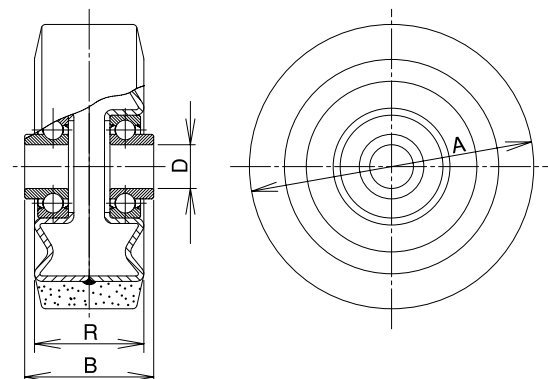
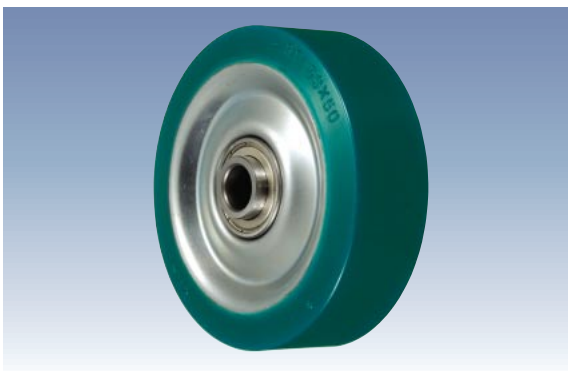

Unit: mm

Size 	Model Number	Load Capacity		Boss Width B 	Tire Width R 	Shaft Diameter D 	Steel Radial Bearing	Weight (g)	Compatible Caster Bracket
		(daN)	(kgf)						
65	RF-65	170	173.4	39	34	12	6201ZZY	400	JM, KH
75	RF-75	200	204.0	39	38	12	6201ZZY	280	
100	RF-100	300	306.0	56	50	12	6201ZZY	540	JM, KH, JMB
130	RF-130	450	459.0	59	50	20	6204ZZY	1,080	JM, JH, KH, JMB
150	RF-150	500	510.0	59	50	20	6204ZZY	1,300	JM, JH, JHW, KH, KHW, JMB, JHB
200	RF-200	600	612.0	70	63	25	6205ZZY	2,570	JM, JH, JHW, KH, KHW, JMB

Wheel Rim: RF-65 Iron Rim
RF-75~200 Steel

RR Type

Wheel

RR Type Heavy Duty MC Nylon Wheel

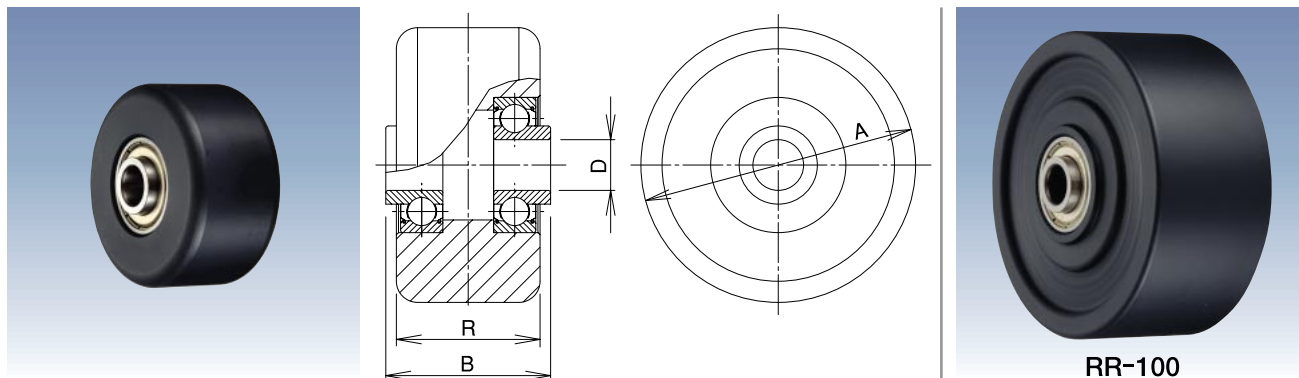

Unit: mm

Size 	Model Number	Load Capacity		Boss Width B 	Tire Width R 	Shaft Diameter D 	Steel Radial Bearing	Weight (g) 	Compatible Caster Bracket
		(daN)	(kgf)						
50	RR-50	220	224.4	29	27	10	6200ZZY	110	T, TN, TH, JM, KH
65	RR-65	330	336.6	39	34	12	6201ZZY	180	JM, KH
	TRR-65	330	336.6	29	25	12	6201ZZY	150	TH
75	RR-75	440	448.8	39	36	12	6201ZZY	230	JM, KH
100	RR-100	550	561.0	56	45	12	6201ZZY	440	JM, KH, JMB

RR-50/65/75/100 Monomer Cast Nylon Wheel

RR Type Heavy Duty Aluminum Rim · MC Nylon Wheel

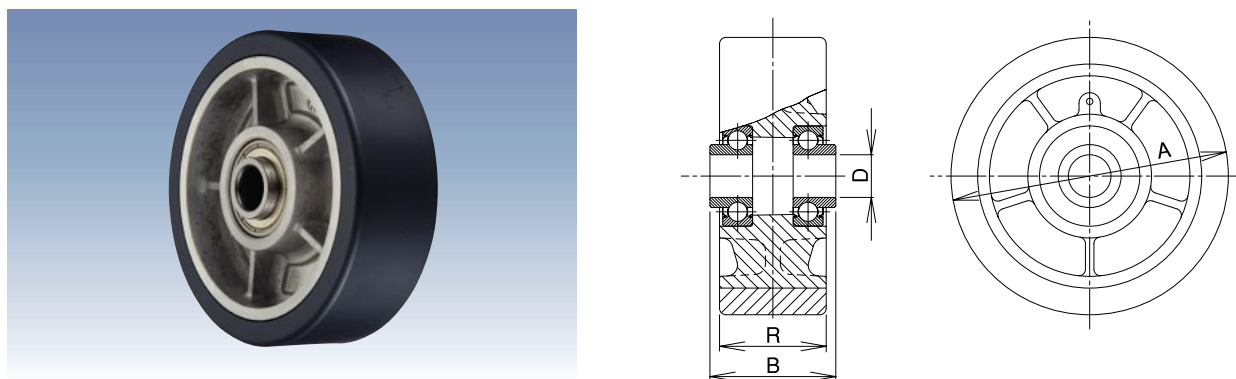

Unit: mm

Size 	Model Number	Load Capacity		Boss Width B 	Tire Width R 	Shaft Diameter D 	Steel Radial Bearing	Weight (g) 	Compatible Caster Bracket
		(daN)	(kgf)						
130	RR-130	500	510.0	59	50	20	6204ZZY	1,060	JM, JH, KH, JMB
150	RR-150	550	561.0	59	50	20	6204ZZY	1,240	JM, JH, KH, JMB, JHB
200	RR-200	660	673.2	70	63	25	6205ZZY	2,410	JM, JH, KH, JMB

Wheel Rim: RR-130/150/200 Aluminum alloy for die casting (ADC-12)

UWB_{Type}

Wheel

UWB Type MC Nylon Wheel

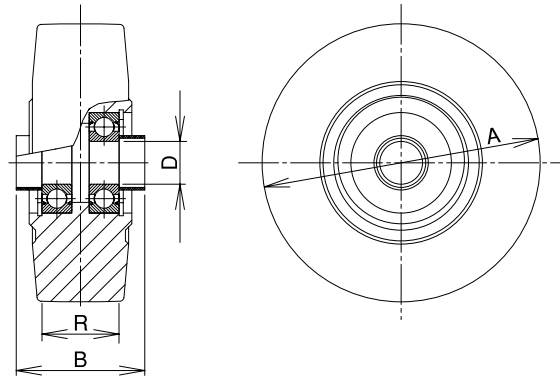
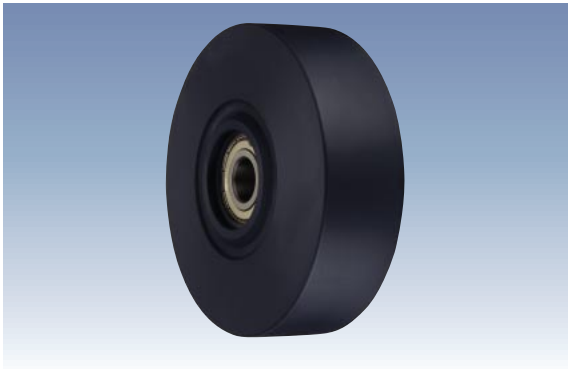

Unit: mm

Size 	Model Number	Load Capacity		Boss Width B 	Tire Width R 	Shaft Diameter D 	Steel Radial Bearing	Weight (g) 	Compatible Caster Bracket
		(daN)	(kgf)						
75	UWB-75	360	367.2	39	24	10	6200ZZ	190	J, K, JB, KBZ, JA, KA, JAB, KABZ
100	UWB-100	520	530.4	42	29	12	6201ZZ	370	J, K, JB, KBZ, JA, KA, JAB, KABZ
				57				380	JM, KH, JMB
130	UWB-130	890	907.8	52	36	20	6204ZZ	800	J, K, JB, KBZ, JA, KA, JAB, KABZ
				60				810	JM, JH, KH, JMB
150	UWB-150	1,040	1,060.8	55	40	20	6204ZZ	1,090	J, K, JB, KBZ, JA, KA, JAB, KABZ
				60				1,100	JM, JH, KH, JMB, JHB
200	UWB-200 ϕ 20	1,400	1,428.0	55	42	20	6204ZZ	1,900	J, K, JB, KBZ, JA, KA, JAB, KABZ
	UWB-200 ϕ 25			71		25	6205ZZ	1,940	JM, JH, KH, JMB

Monomer Cast Nylon Wheel (with Steel Collar)

When placing an order for UWB-100, 130, or 150, please specify boss width.

Please be careful about the load capacity of the mounting bracket.



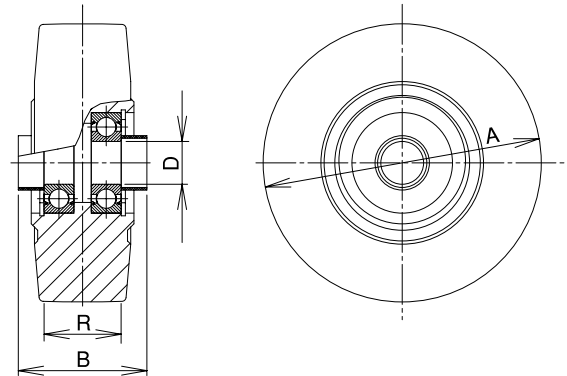
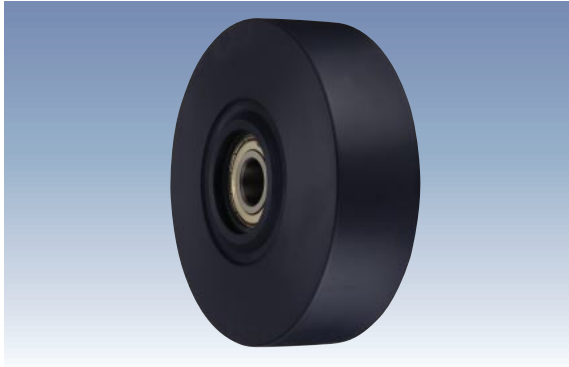

UWBD_{Type}

Wheel

UWBD Type MC Nylon Wheel (Including Stainless Steel Bearings)



Unit: mm

Size 	Model Number	Load Capacity		Boss Width B 	Tire Width R 	Shaft Diameter D 	Stainless Steel Radial Bearing	Weight (g) 	Compatible Caster Bracket
		(daN)	(kgf)						
75	UWBD-75	360	367.2	39	24	10	SUS 6200ZZ	190	J, K, JB, KBZ JA, KA, JAB, KABZ
100	UWBD-100	520	530.4	42	29	12	SUS 6201ZZ	370	
130	UWBD-130	890	907.8	52	36	20	SUS 6204ZZ	800	
150	UWBD-150	1,040	1,060.8	55	40	20	SUS 6204ZZ	1,090	
200	UWBD-200	1,400	1,428.0	55	42	20	SUS 6204ZZ	1,900	

Monomer Cast Nylon Wheel (with Stainless Steel Collar)

Please be careful about the load capacity of the mounting bracket.

UWA_{Type}

Wheel

UWA Type MC Nylon Wheel (Spindle Sleeve)

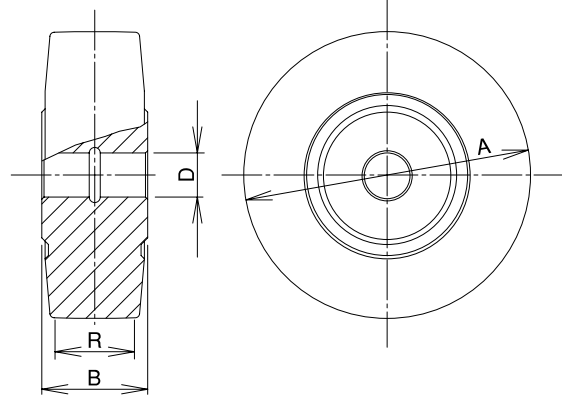
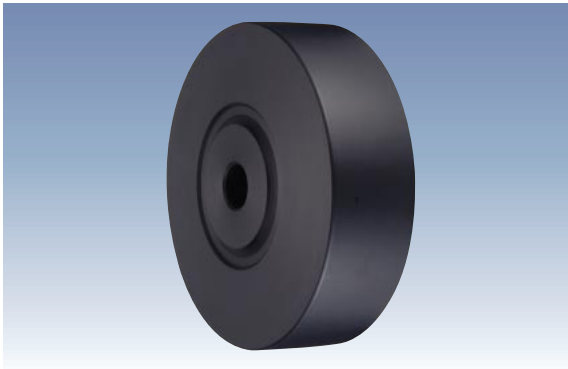

Unit: mm

Size 	Model Number	Load Capacity		Boss Width B 	Tire Width R 	Shaft Diameter D 	Bearing	Weight (g) 	Compatible Caster Bracket
		(daN)	(kgf)						
75	UWA-75	360	367.2	34	24	10	Spindle Sleeve	150	J, K, JB, KBZ JA, KA, JAB, KABZ
100	UWA-100	520	530.4	40	29	12		320	
130	UWA-130	890	907.8	48	36	20		650	
150	UWA-150	1,040	1,060.8	52	40	20		940	
200	UWA-200	1,400	1,428.0	54	42	20		1,750	

Monomer Cast Nylon Wheel

Please be careful about the load capacity of the mounting bracket.

* The wheel with a spindle sleeve may cause trudge, noise, etc. when heavily loaded. When heavily loaded, we recommend you to use a wheel bearings (UWB type, Page 94 / UWBD type, Page 95).

UWBS/UWBSD Type

Wheel

UWBS Type MC Nylon Wheel [Slim Type]

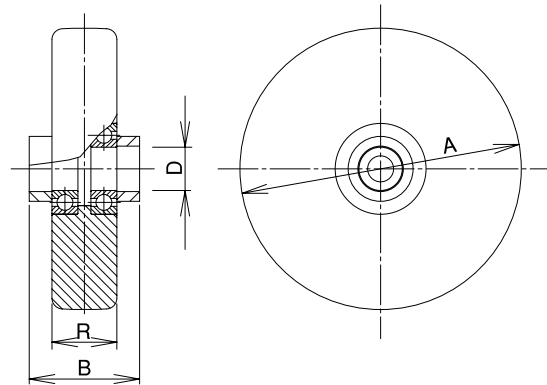
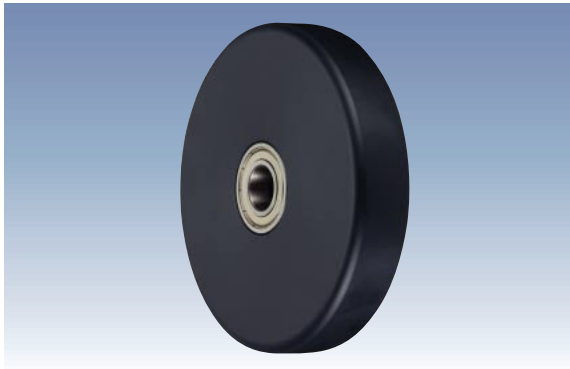

Unit: mm

Size 	Model Number	Load Capacity		Boss Width B 	Tire Width R 	Shaft Diameter D 	Steel Radial Bearing	Weight (g) 	Compatible Caster Bracket
		(daN)	(kgf)						
75	UWBS-75	250	255.0	39	26	10	6200ZZ	170	J, K, JB, KBZ JA, KA, JAB, KABZ
100	UWBS-100	350	357.0	42	30	12	6201ZZ	320	
130	UWBS-130	500	510.0	52	30	20	6004ZZ	540	
150	UWBS-150	600	612.0	55	30	20	6004ZZ	690	
200	UWBS-200 ϕ 20	900	918.0	55	34	20	6204ZZ	1,360	J, K, JB, KBZ JA, KA, JAB, KABZ
	UWBS-200 ϕ 25			71	36	25	6205ZZ	1,490	—
250	UWBS-250	1,000	1,020.0	88	36	25	6205ZZ	2,240	J, K, JB

Monomer Cast Nylon Wheel (with MC Nylon Collar)

* Only for UWBS-200 ϕ 25, steel collar is used.

Build-to-order manufacturing

Please be careful about the load capacity of the mounting bracket.

UWBSD Type MC Nylon Wheel [Slim Type] (Including Stainless Steel Bearings)

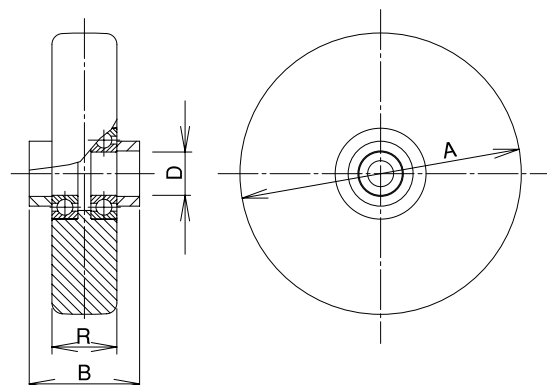
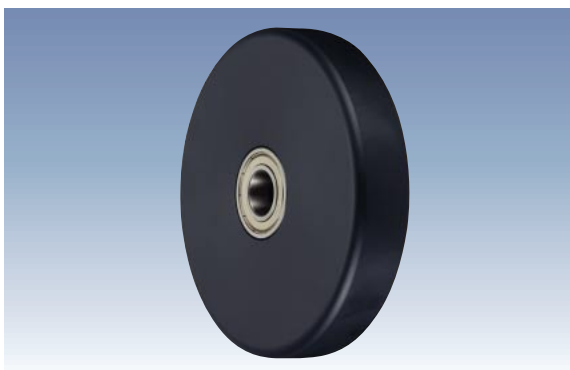

Unit: mm

Size 	Model Number	Load Capacity		Boss Width B 	Tire Width R 	Shaft Diameter D 	Stainless Steel Radial Bearing	Weight (g) 	Compatible Caster Bracket
		(daN)	(kgf)						
75	UWBSD-75	250	255.0	39	26	10	SUS 6200ZZ	170	J, K, JB, KBZ JA, KA, JAB, KABZ
100	UWBSD-100	350	357.0	42	30	12	SUS 6201ZZ	320	
130	UWBSD-130	500	510.0	52	30	20	SUS 6004ZZ	540	
150	UWBSD-150	600	612.0	55	30	20	SUS 6004ZZ	690	
200	UWBSD-200	900	918.0	55	34	20	SUS 6204ZZ	1,360	

Monomer Cast Nylon Wheel (with MC Nylon Collar)

Please be careful about the load capacity of the mounting bracket.

F/FA Type

Wheel

F Type Steel Wheel

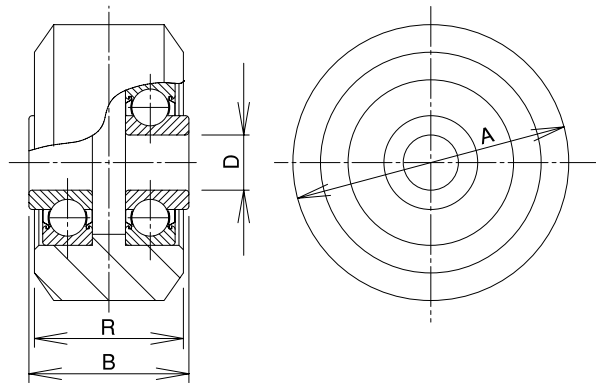
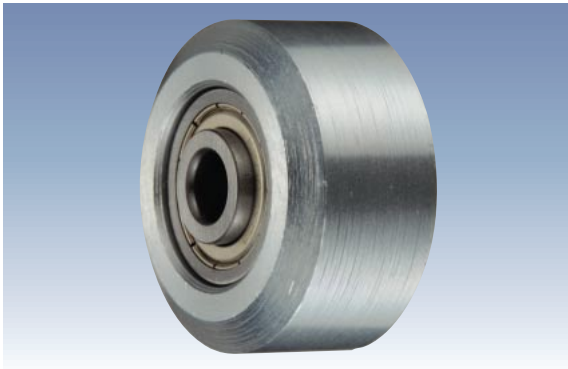

Unit: mm

Size 	Model Number	Load Capacity		Boss Width B 	Tire Width R 	Shaft Diameter D 	Steel Radial Bearing	Weight (g) 	Compatible Caster Bracket
		(daN)	(kgf)						
50	F-50	100	102.0	29	27	10	6200ZZY	320	T, TN, TH, JM, KH
65	TF-65	100	102.0	29	25	12	6201ZZY	550	TH

FA Type Steel Wheel (Spindle Sleeve)

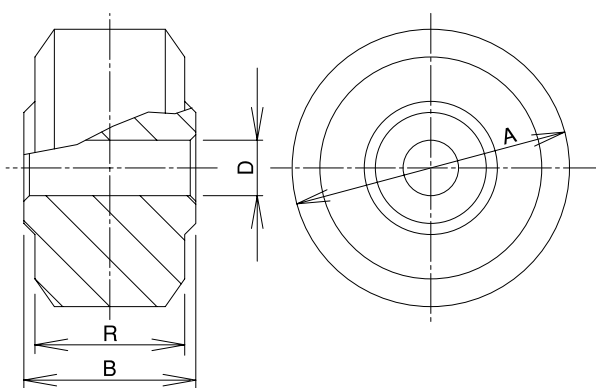
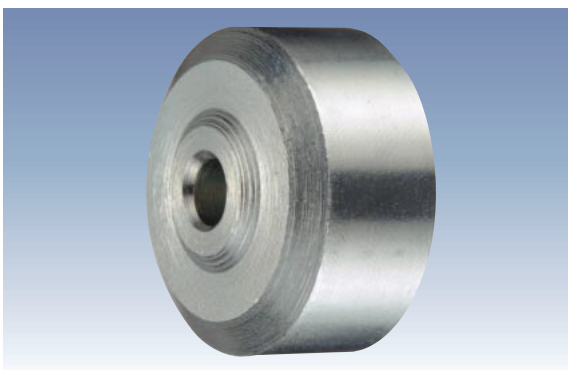

Unit: mm

Size 	Model Number	Load Capacity		Boss Width B 	Tire Width R 	Shaft Diameter D 	Bearing	Weight (g) 	Compatible Caster Bracket
		(daN)	(kgf)						
50	FA-50	60	61.2	31	27	10	Spindle Sleeve	390	T, TN, JM, KH

Medium Weight Caster Series

HJ Type









Size: 130mm~150mm

Medium Weight Swivel Caster



HJ-130

HJ-150

Size 	Model Number	Wheel	Bearing	Load Capacity		Tire Width R 	Shaft Diameter D 	Overall Height H1 	Plate Size F1/F2 	Mounting Hole Spacing P1/P2 (P1'/P2') 	Plate Hole d 	Offset E 	Weight (g) 
				(daN)	(kgf)								
130	HJ-130	Rubber	B/B	150	153.0	42	12	177	108/108	80/80	11	40	1,540
150	HJ-150	Rubber	B/B	180	183.6	38	12	187	100/100	※80/80 (75/75)	11	40	1,710



Unit: mm

Bearing: B/B -- Steel bearing

※Oval-shaped screw holes

【Bracket Dimensions】

Unit: mm

Size 	Bracket Height H 	Bracket Width B 
130	112	53
150	112	53

* The shaft set is included in the bracket.

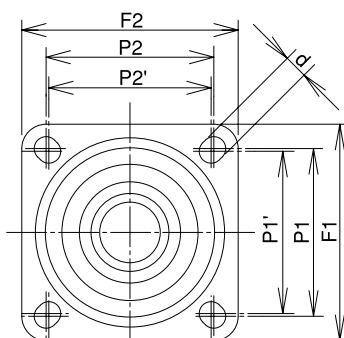

HJ-150

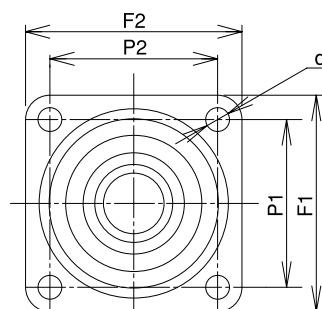

HJ-130

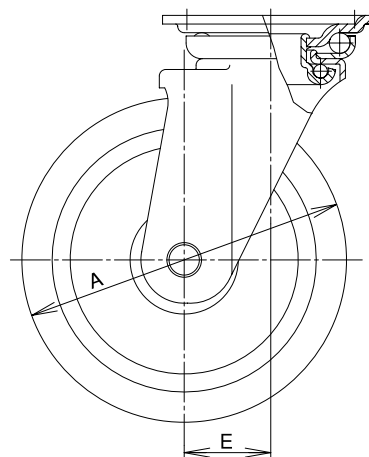
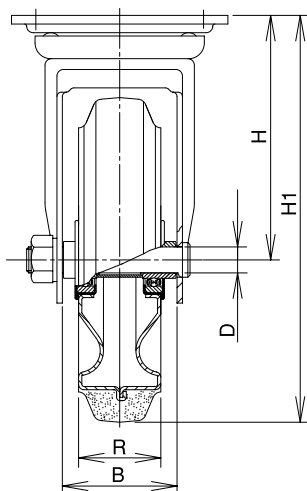





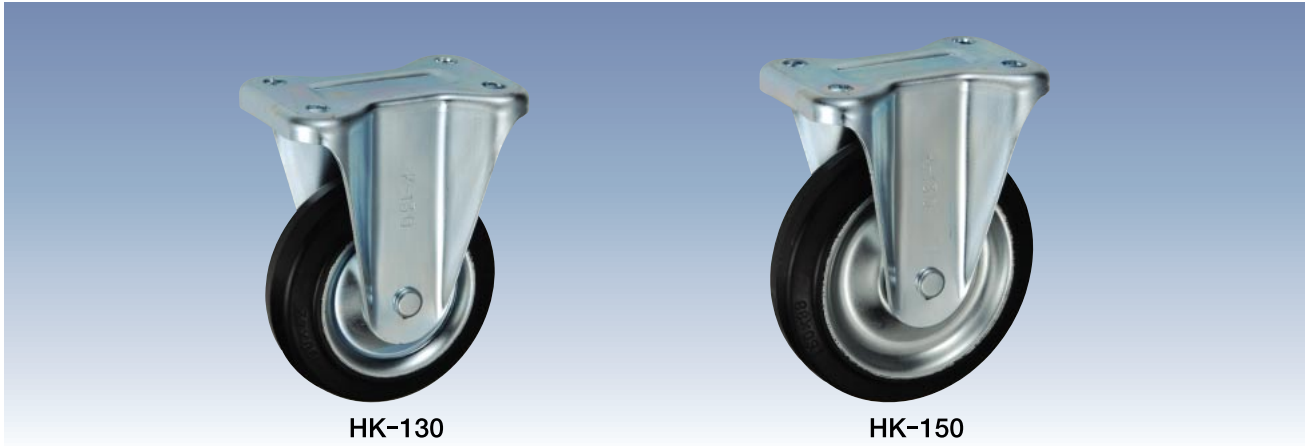



HK Type

Size: 130mm~150mm

Medium Weight Rigid Caster

HK-130
HK-150

Unit: mm



Size 	Model Number	Wheel	Bearing	Load Capacity		Tire Width R 	Shaft Diameter D 	Overall Height H1 	Plate Size F1/F2 	Mounting Hole Spacing P1/P2 (P2') 	Plate Hole d 	Weight (g) 
				(daN)	(kgf)							
130	HK-130	Rubber	B/B	150	153.0	42	12	177	137/93	※100/56 (50)	11	1,270
150	HK-150	Rubber	B/B	180	183.6	38	12	187	137/93	※100/56 (50)	11	1,410

Bearing: B/B -- Steel bearing

※Oval-shaped screw holes

[Bracket Dimensions]

Unit: mm

Size 	Bracket Height H 	Bracket Width B 
130	112	53
150	112	53

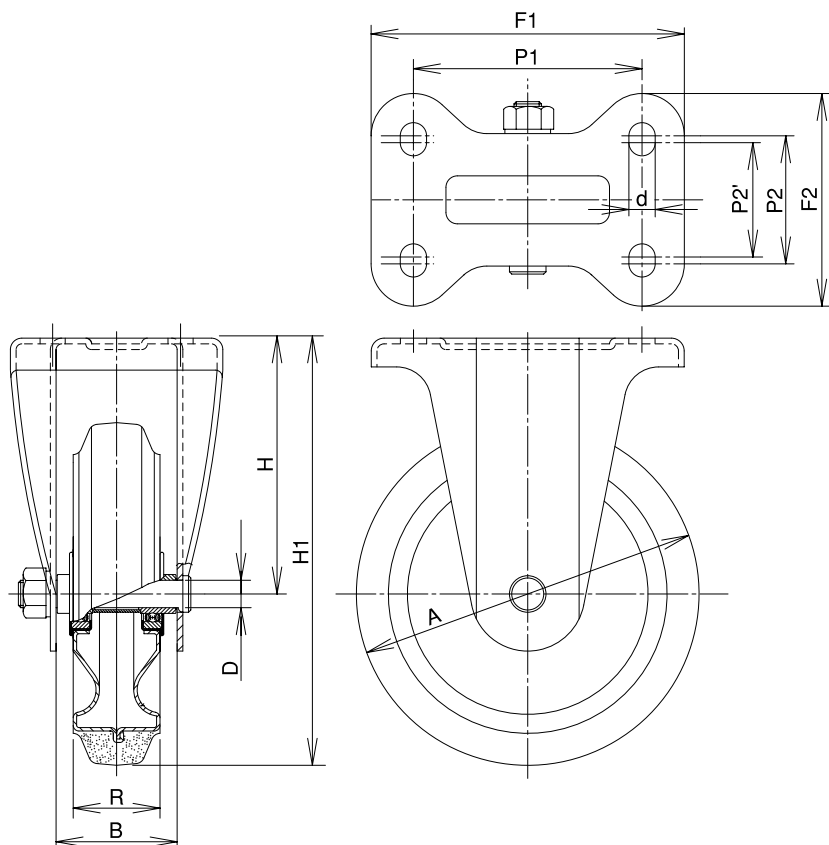

HJS Type





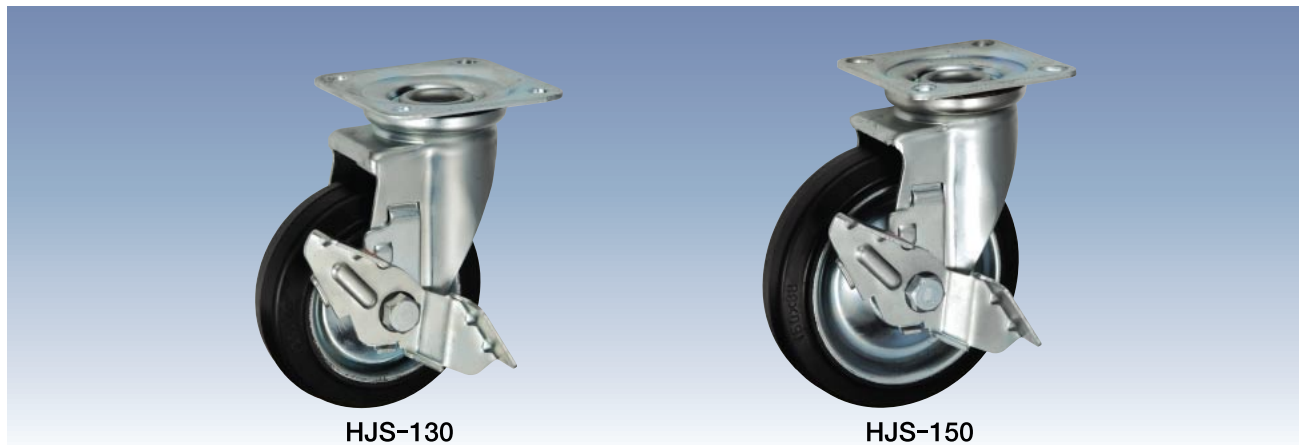



Size: 130mm~150mm

Medium Weight Swivel Caster with Stopper



HJS-130

HJS-150

Size 	Model Number	Wheel	Bearing	Load Capacity		Tire Width R 	Shaft Diameter D 	Overall Height H1 	Plate Size F1/F2 	Mounting Hole Spacing P1/P2 (P1'/P2') 	Plate Hole d 	Offset E 	Weight (g) 
				(daN)	(kgf)								
130	HJS-130	Rubber	B/B	150	153.0	42	12	177	108/108	80/80	11	40	1,770
150	HJS-150	Rubber	B/B	180	183.6	38	12	187	100/100	※80/80 (75/75)	11	40	1,920

Unit: mm



Bearing: B/B -- Steel bearing

※Oval-shaped screw holes

The stopper of the HJS Type caster can lock the wheel to stop the caster.

【Bracket Dimensions】

Unit: mm

Size 	Bracket Height H 	Bracket Width B 
130	112	53
150	112	53

* The shaft set is included in the bracket.

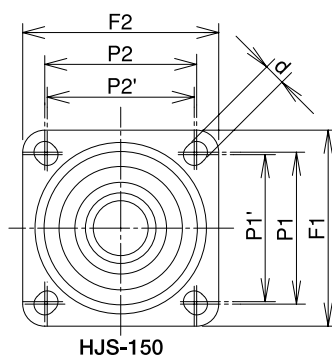

HJS-150

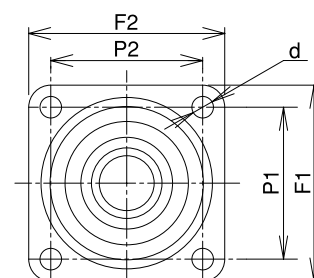

HJS-130

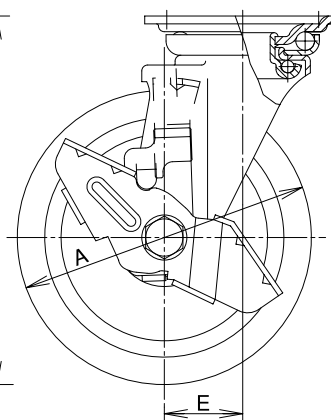
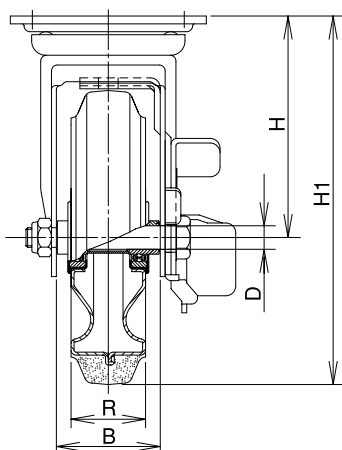

H Type



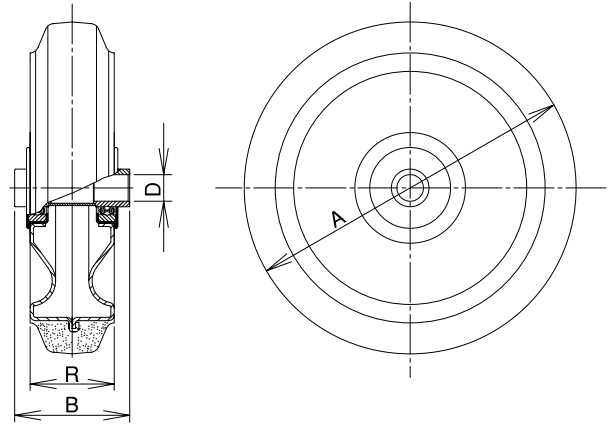

Size: 130mm~150mm

Wheel

H Type Steel Rim · Polybutadiene Rubber Wheel



Unit: mm

Size 	Model Number	Load Capacity		Boss Width B 	Tire Width R 	Shaft Diameter D 	Steel Ball Bearing	Weight (g) 	Compatible Caster Bracket
		(daN)	(kgf)						
130	H-130	150	153.0	52	42	12	201BL	620	HJ, HK, HJS
150	H-150	180	183.6	52	38	12	201BLL	730	

Wheel Rim: Steel

Silent Running Caster Series

Reduces the Noise of Brackets and Wheels while Running!

Distinctive Features

The UKAI silent running caster replaces the original ball bearings in the swivel part of J type bracket with the radial bearings and bearing holder, and also replaces the original pressed bearings in the wheel with radial bearings. This improvement successfully reduced the noise of brackets and wheels while running.

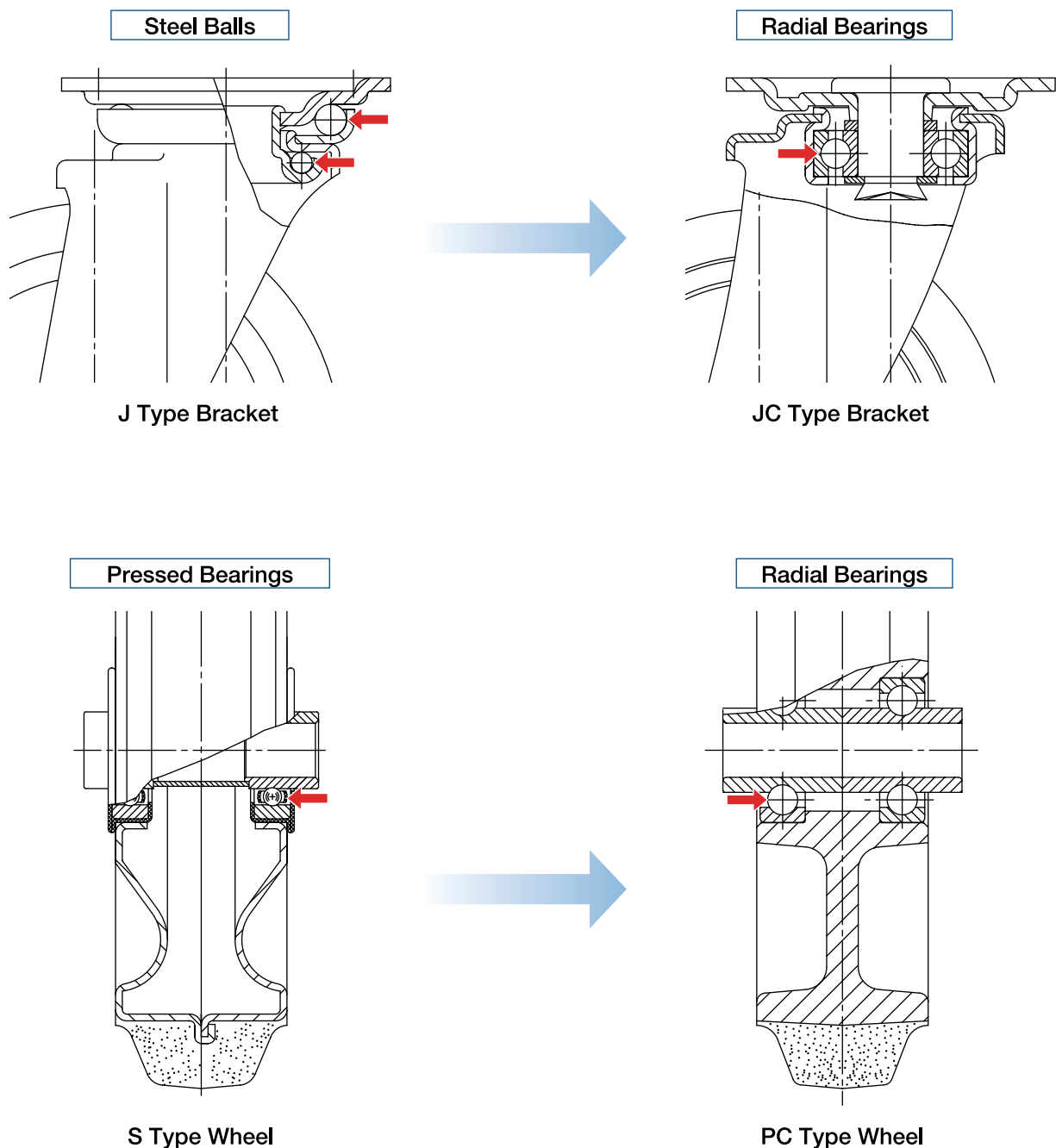

PCJC_{Type} Size: 100mm~150mm

Silent Running Swivel Caster



PCJC-100

PCJC-125

PCJC-151

Unit: mm

Size 	Model Number	Wheel	Bearing	Load Capacity		Tire Width R	Shaft Diameter D	Overall Height H1	Plate Size F1/F2	Mounting Hole Spacing P1/P2 (P1'/P2')	Plate Hole d	Offset E	Weight (g)
				(daN)	(kgf)								
100	PCJC-100	Rubber	B/B	120	122.4	32	10	132	90/90	※71/71 (68/68)	11	34	900
125	PCJC-125	Rubber	B/B	150	153.0	38	12	168	100/100	※80/80 (75/75)	11	38	1,420
150	PCJC-151	Rubber	B/B	180	183.6	38	12	190	100/100	※80/80 (75/75)	11	40	1,520

Bearing: B/B -- Steel radial bearing

※Oval-shaped screw holes

[Bracket Dimensions] Unit: mm

Size 	Bracket Height H	Bracket Width B
100	82	42
125	105	53
150	115	53

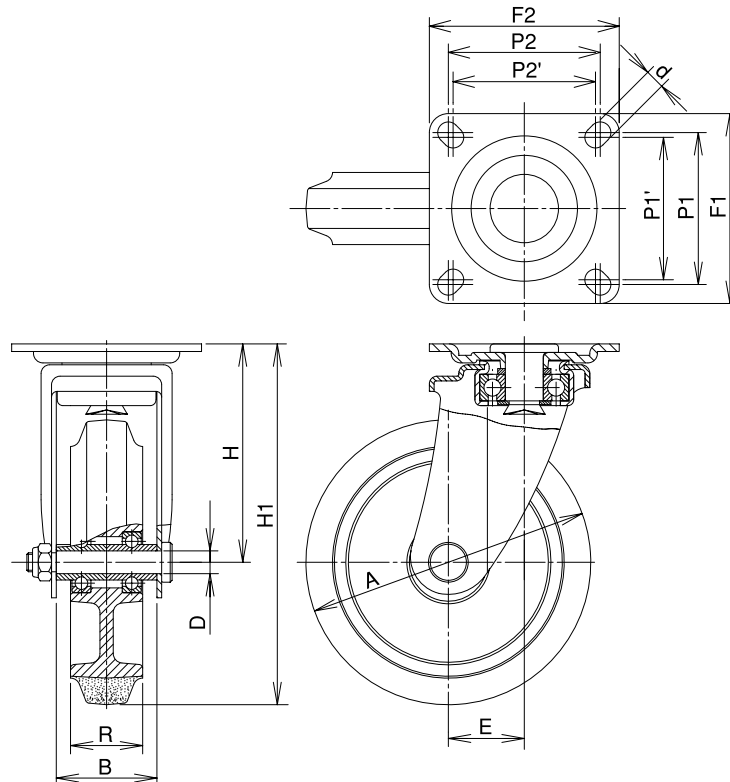

PCKE_{Type} Size: 100mm~150mm

Silent Running Rigid Caster



Size A	Model Number	Wheel	Bearing	Load Capacity		Tire Width R	Shaft Diameter D	Overall Height H1	Plate Size F1/F2	Mounting Hole Spacing P1/P2 (P1'/P2')	Plate Hole d	Weight (g)
				(daN)	(kgf)							
100	PCKE-100	Rubber	B/B	120	122.4	32	10	132	110/78	※80/45 (90/50)	11	650
125	PCKE-125	Rubber	B/B	150	153.0	38	12	168	140/94	※100/56 (112/53)	11	1,120
150	PCKE-151	Rubber	B/B	180	183.6	38	12	190	140/94	※100/56 (112/53)	11	1,260

Bearing: B/B -- Steel radial bearing

※Oval-shaped screw holes

【Bracket Dimensions】

Unit: mm

Size A	Bracket Height H	Bracket Width B
100	82	42
125	105	53
150	115	53

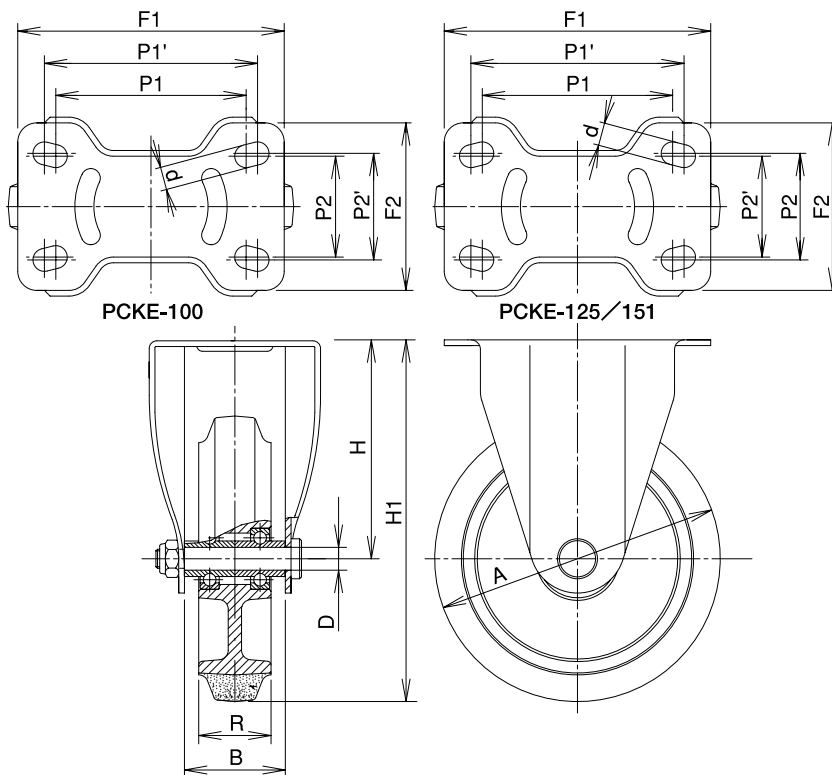

PCKC_{Type} Size: 100mm~150mm

Silent Running Rigid Caster



PCKC-100

PCKC-125

PCKC-151

Unit: mm

Size 	Model Number	Wheel	Bearing	Load Capacity		Tire Width R	Shaft Diameter D	Overall Height H1	Plate Size F1/F2	Mounting Hole Spacing P1/P2 (P1'/P2')	Plate Hole d	Weight (g)
				(daN)	(kgf)							
100	PCKC-100	Rubber	B/B	120	122.4	32	10	132	95/90	※71/71 (68/68)	11	650
125	PCKC-125	Rubber	B/B	150	153.0	38	12	168	105/105	※80/80 (75/75)	11	940
150	PCKC-151	Rubber	B/B	180	183.6	38	12	190	105/105	※80/80 (75/75)	11	1,070

Bearing: B/B -- Steel radial bearing

※Oval-shaped screw holes

[Bracket Dimensions] Unit: mm

Size 	Bracket Height H	Bracket Width B
100	82	42
125	105	53
150	115	53

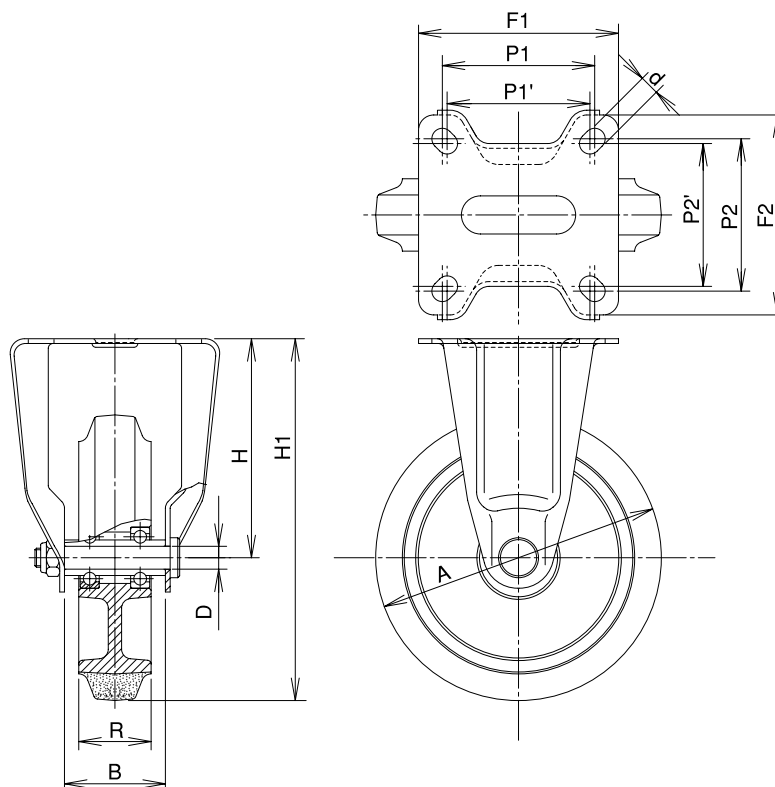

PCJCS Type Size: 100mm~150mm

Silent Running Swivel Caster with Stopper



PCJCS-100

PCJCS-125

PCJCS-151

Unit: mm

Size A	Model Number	Wheel	Bearing	Load Capacity		Tire Width R	Shaft Diameter D	Overall Height H1	Plate Size F1/F2	Mounting Hole Spacing P1/P2 (P1'/P2')	Plate Hole d	Offset E	Weight (g)
				(daN)	(kgf)								
100	PCJCS-100	Rubber	B/B	120	122.4	32	10	132	90/90	※71/71 (68/68)	11	34	970
125	PCJCS-125	Rubber	B/B	150	153.0	38	12	168	100/100	※80/80 (75/75)	11	38	1,590
150	PCJCS-151	Rubber	B/B	180	183.6	38	12	190	100/100	※80/80 (75/75)	11	40	1,730

Bearing: B/B -- Steel radial bearing

※Oval-shaped screw holes

The stopper of the PCJCS Type caster can lock the wheel to stop the caster.

【Bracket Dimensions】

Unit: mm

Size A	Bracket Height H	Bracket Width B
100	82	42
125	105	53
150	115	53

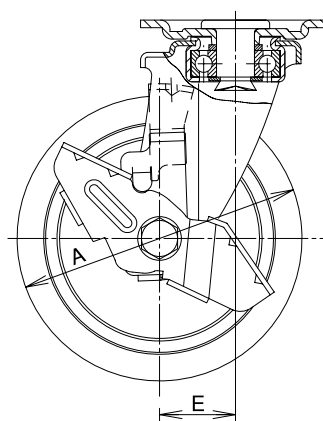
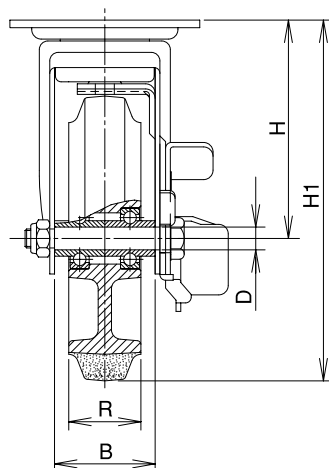
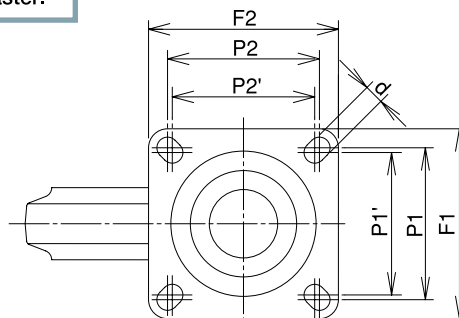

PC Type

Size: 100mm~150mm

Wheel

PC Type **Silent Running** Nylon Rim · Polybutadiene Rubber Wheel



PC-100

PC-125

PC-151

Unit: mm

Size 	Model Number	Load Capacity		Boss Width B 	Tire Width R 	Shaft Diameter D 	Steel Radial Bearing	Weight (g) 	Compatible Caster
		(daN)	(kgf)						
100	PC-100	120	122.4	42	32	10	6200ZZL	270	PCJC PCKC, PCKE PCJCS
125	PC-125	150	153.0	53	38	12	6201ZZL	410	
150	PC-151	180	183.6	53	38	12	6201ZZL	500	

Wheel Rim: Nylon6

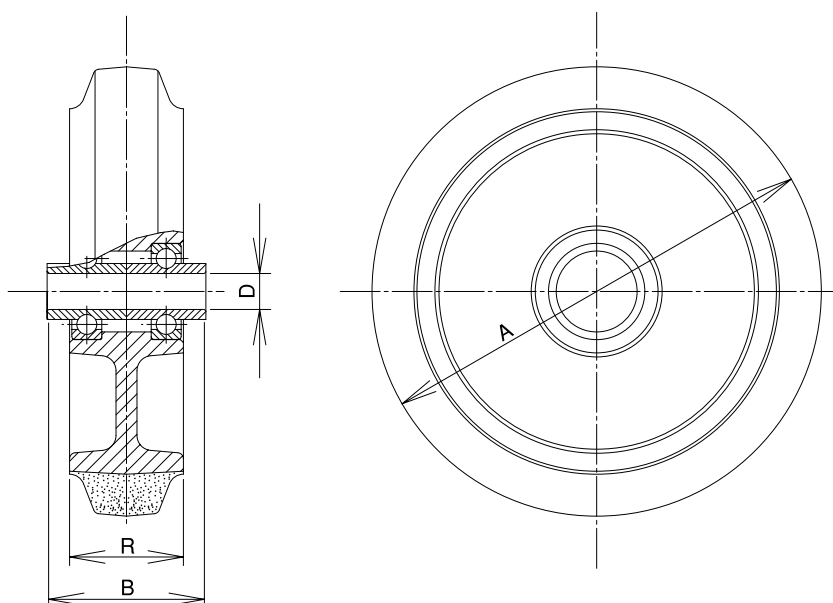



UKAI CASTERS

Pneumatic Rubber / Airless Wheel Casters

HLJ/HFJF Type

Swivel Bracket for Pneumatic Rubber / Airless Wheel



HLJ6 $\frac{1}{2}$ ×2-3

HLJ2.00-4

Unit: mm

Model Number	Wheel	Bearing	Load Capacity		Tire		Standard Air Pressure (kgf/cm ²)	Shaft Diameter D	Overall Height H1	Plate Size F1/F2	Mounting Hole Spacing P1/P2 (P1'/P2')	Plate Hole d	Offset E	Weight (g)
			kg	daN	A	R								
HLJ6 $\frac{1}{2}$ ×2-3	BLACK	B/B	60	61.2	175	51	2.5	12	210	120/120	※90/90 (80/80)	11	45	1,500
	GRAY	B/B			181									1,500
	PU	B/B			—									1,650
HLJY6 $\frac{1}{2}$ ×2-3	BLACK	B/B	60	61.2	175	51	2.5	12	210	128/98	100/56	11	45	1,490
	GRAY	B/B			181									1,490
	PU	B/B			—									1,640
HLJ2.00-4	BLACK	B/B	80	81.6	210	50	2.5	20	260	140/140	112/112	11	58	3,490
	GRAY	B/B			—									3,490
HLJ6 $\frac{1}{2}$ ×2-4	BLACK	B/B	80	81.6	175	40	2.5	20	237	140/140	112/112	11	58	3,440
	GRAY	B/B			—									3,440
HFJF6 $\frac{1}{2}$ ×2-4	BLACK	B/B	80	81.6	169	50	2.5	20	234	140/140	112/112	14	58	4,090
	GRAY	B/B			—									4,090
HLJ2.50-4	BS	B/B	85	86.7	225	65	3.5	20	292	160/160	125/125	14	71	4,920
	FO	B/B			218				289					4,830
	AL	B/B	100	102.0	220	60	—	290	6,050					
HLETJ2.50-4	BS	B/B	85	86.7	225	65	3.5	20	292	140/140	112/112	14	58	4,520
	FO	B/B			218				289					4,430
	AL	B/B	100	102.0	220	60	—	290	5,650					

Bearing: B/B -- Steel bearing

※Oval-shaped screw holes

Wheel: BLACK -- Tire Color : BLACK
 GRAY -- Tire Color : GRAY
 PU -- PU Type Airless Tire (Foaming Urethane)
 BS -- Tire Made by Bridgestone
 FO -- Tire Made by an Overseas Maker
 AL -- Airless / Solid Tire

The outer diameter and width of a tire were measured at the standard air pressure under the unloaded condition. They may vary according to usage conditions.

HLJ/HFJF Type

Swivel Bracket for Pneumatic Rubber / Airless Wheel



HLJ2.50-4

HLJ3.50-5

Unit: mm

Model Number	Wheel	Bearing	Load Capacity		Tire		Standard Air Pressure (kgf/cm ²)	Shaft Diameter D	Overall Height H1	Plate Size F1/F2	Mounting Hole Spacing P1/P2 (P1'/P2')	Plate Hole d	Offset E	Weight (g)
			kg	daN	Diameter A	Width R								
HLJ3.00-4	BS	B/B	110	112.2	253	82	3.5	20	306	160/160	125/125	14	71	5,190
	FO	B/B			250	76			305					5,080
	AL	B/B			130	132.6			248					73
HLETJ3.00-4	BS	B/B	110	112.2	253	82	3.5	20	306	140/140	112/112	14	58	4,780
	FO	B/B			250	76			305					4,680
	AL	B/B			130	132.6			248					73
HLJ8×3.00-4	FO	B/B	85	86.7	218	67	3.5	20	289	160/160	125/125	14	71	4,760
	AL	B/B	100	102.0	210	65	—		285					5,960
HLJ3.50-5	BS	B/B	160	163.2	295	90	3.5	25	371	175/175	140/140	14	71	7,110
	FO	B/B			286	90			367					7,110
	AL	B/B			200	204.0			286					90

Bearing: B/B -- Steel bearing

Wheel: BS -- Tire Made by Bridgestone
 FO -- Tire Made by an Overseas Maker
 AL -- Airless / Solid Tire

The outer diameter and width of a tire were measured at the standard air pressure under the unloaded condition. They may vary according to usage conditions.

Bracket Dimensions

Unit: mm

Model Number	Bracket Height H	Bracket Width B	Weight (g)
J6 $\frac{1}{2}$ ×2-3	123	63	820
JY6 $\frac{1}{2}$ ×2-3	123	63	810
J2.00-4	155	56	2,380
J6 $\frac{1}{2}$ ×2-4	150	56	2,380
JF6 $\frac{1}{2}$ ×2-4	150	90	2,820
J2.50-4	180	90	3,370
J2.50-4ET	180	90	2,970
J3.00-4	180	90	3,370
J3.00-4ET	180	90	2,970
J8×3.00-4	180	90	3,370
J3.50-5	224	110	4,500

* The shaft set is included in the bracket.

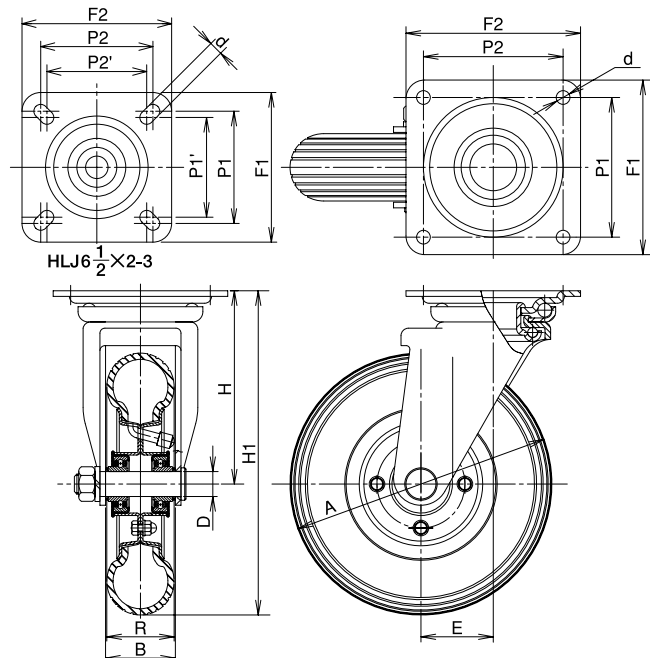

HLK/HFKF Type

Rigid Bracket for Pneumatic Rubber / Airless Wheel



HLK6 $\frac{1}{2}$ × 2-3

HLK2.00-4

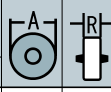
Model Number	Wheel	Bearing	Load Capacity		Tire		Standard Air Pressure (kgf/cm ²)	Shaft Diameter D	Overall Height H1	Plate Size F1/F2	Mounting Hole Spacing P1/P2	Plate Hole d	Weight (g)		
			 (daN)	(kgf)	Diameter A	Width R									
															
HLK6 $\frac{1}{2}$ × 2-3	BLACK	B/B	60	61.2	175	51	2.5	12	210	127/87	100/56	11	1,260		
	GRAY	B/B			181								—	213	1,260
	PU	B/B			—								—	—	1,410
HLK2.00-4	BLACK	B/B	80	81.6	210	50	2.5	20	260	151/102	112/63	11	2,860		
	GRAY	B/B											2,860		
HLK6 $\frac{1}{2}$ × 2-4	BLACK	B/B	80	81.6	175	40	2.5	20	237	151/102	112/63	11	2,810		
	GRAY	B/B											2,810		
HFKF6 $\frac{1}{2}$ × 2-4	BLACK	B/B	80	81.6	169	50	2.5	20	234	158/120	112/63	14	2,910		
	GRAY	B/B											2,910		
HLK2.50-4	BS	B/B	85	86.7	225	65	3.5	20	292	200/140	140/80	14	4,350		
	FO	B/B			218	62			289				4,260		
	AL	B/B	100	102.0	220	60	—		290				5,480		
HLETK2.50-4	BS	B/B	85	86.7	225	65	3.5	20	292	158/120	112/63	14	3,300		
	FO	B/B			218	62			289				3,210		
	AL	B/B	100	102.0	220	60	—		290				4,430		

Unit: mm

Bearing: B/B -- Steel bearing

Wheel: BLACK -- Tire Color : BLACK
 GRAY -- Tire Color : GRAY
 PU -- PU Type Airless Tire (Foaming Urethane)
 BS -- Tire Made by Bridgestone
 FO -- Tire Made by an Overseas Maker
 AL -- Airless / Solid Tire

The outer diameter and width of a tire were measured at the standard air pressure under the unloaded condition. They may vary according to usage conditions.

HLK/HFKF Type

Rigid Bracket for Pneumatic Rubber / Airless Wheel



HLK2.50-4

HLK3.50-5

Unit: mm

Model Number	Wheel	Bearing	Load Capacity		Tire		Standard Air Pressure (kgf/cm ²)	Shaft Diameter D	Overall Height H1	Plate Size F1/F2	Mounting Hole Spacing P1/P2	Plate Hole d	Weight (g)
			 (daN)	 (kgf)	 A	 R							
HLK3.00-4	BS	B/B	110	112.2	253	82	3.5	20	306	200/140	140/80	14	4,620
	FO	B/B			250	76			305				4,510
	AL	B/B			248	73			304				6,640
HLETK3.00-4	BS	B/B	110	112.2	253	82	3.5	20	306	158/120	112/63	14	3,570
	FO	B/B			250	76			305				3,460
	AL	B/B			248	73			304				5,590
HLK8×3.00-4	FO	B/B	85	86.7	218	67	3.5	20	289	200/140	140/80	14	4,190
	AL	B/B	100	102.0	210	65	—	285	5,390				
HLK3.50-5	BS	B/B	160	163.2	295	90	3.5	25	371	220/150	160/90	14	6,650
	FO	B/B			286	90			367				6,650
	AL	B/B			286	90			367				9,980

Bearing: B/B -- Steel bearing

Wheel: BS -- Tire Made by Bridgestone
 FO -- Tire Made by an Overseas Maker
 AL -- Airless / Solid Tire

The outer diameter and width of a tire were measured at the standard air pressure under the unloaded condition. They may vary according to usage conditions.

[Bracket Dimensions]

Unit: mm

Model Number	Bracket Height H	Bracket Width B	Weight (g)
K6 $\frac{1}{2}$ ×2-3	123	63	580
K2.00-4	155	56	1,750
K6 $\frac{1}{2}$ ×2-4	150	56	1,750
KF6 $\frac{1}{2}$ ×2-4	150	90	1,640
K2.50-4	180	90	2,800
K2.50-4ET	180	90	1,750
K3.00-4	180	90	2,800
K3.00-4ET	180	90	1,750
K8×3.00-4	180	90	2,800
K3.50-5	224	110	4,040

* The shaft set is included in the bracket.

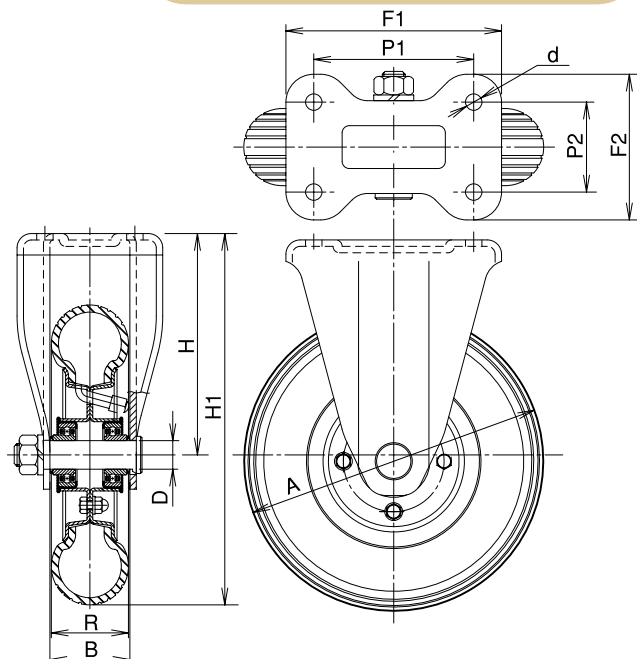

HLJB/HFJBF Type

Swivel Bracket with Stopper for Pneumatic Rubber / Airless Wheel



HLJB2.00-4

HLETJB2.50-4

HLJB3.00-4

Unit: mm

Model Number	Wheel	Bearing	Load Capacity		Tire		Standard Air Pressure (kgf/cm ²)	Shaft Diameter D	Overall Height H1	Plate Size F1/F2	Mounting Hole Spacing P1/P2	Plate Hole d	Offset E	Weight (g)
			kg	daN	A	R								
HLJB2.00-4	BLACK	B/B	80	81.6	210	50	2.5	20	260	140/140	112/112	11	58	3,690
	GRAY	B/B												3,690
HFJBF6 $\frac{1}{2}$ ×2-4	BLACK	B/B	80	81.6	169	50	2.5	20	234	140/140	112/112	14	58	4,340
	GRAY	B/B												4,340
HLETJB2.50-4	BS	B/B	85	86.7	225	65	3.5	20	292	140/140	112/112	14	58	4,780
	FO	B/B			218	62			289					4,690
	AL	B/B	100	102.0	220	60	—	20	290	—	—	—	—	5,910
HLJB3.00-4	BS	B/B	110	112.2	253	82	3.5	20	306	160/160	125/125	14	71	5,480
	FO	B/B			250	76			305					5,370
	AL	B/B	130	132.6	248	73	—	20	304	—	—	—	—	7,500

Bearing: B/B -- Steel bearing

- Wheel: BLACK -- Tire Color : BLACK
 GRAY -- Tire Color : GRAY
 PU -- PU Type Airless Tire (Foaming Urethane)
 BS -- Tire Made by Bridgestone
 FO -- Tire Made by an Overseas Maker
 AL -- Airless / Solid Tire

The outer diameter and width of a tire were measured at the standard air pressure under the unloaded condition. They may vary according to usage conditions.

[Bracket Dimensions]

Model Number	Bracket Height H	Bracket Width B	Weight (g)
JB2.00-4	155	56	2,580
JBF6 $\frac{1}{2}$ ×2-4	150	90	3,070
JB2.50-4ET	180	90	3,230
JB3.00-4	180	90	3,660

* The shaft set is included in the bracket.

[Pedal Dimensions]

Model Number	Pedal Rod K	Radius of Gyration S
JB2.00-4	120	148
JBF6 $\frac{1}{2}$ ×2-4	130	156
JB2.50-4ET	130	156
JB3.00-4	135	160

The JB Type bracket can lock or unlock the wheel and frame at the same time just by stepping the pedal. This was designed under the assumption that it is combined with the pneumatic rubber / airless wheel produced by our company. If this is combined with a tire whose outer diameter is not within the range below, the tire may slip or the tire may interfere with the stopper mechanism. Use the tire with the specified air pressure.

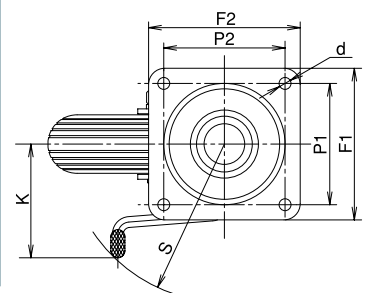

Compatible Tire Diameter (Rough Standard)
210~206
169~166
225~216
253~248

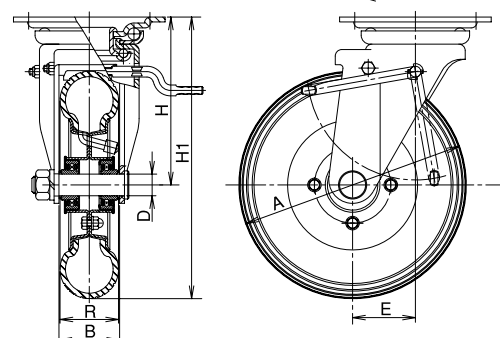

UKAI Pneumatic Wheels

Pneumatic Rubber Wheel / Airless Wheel

6 1/2 x 2-3HL Pneumatic Rubber Wheel

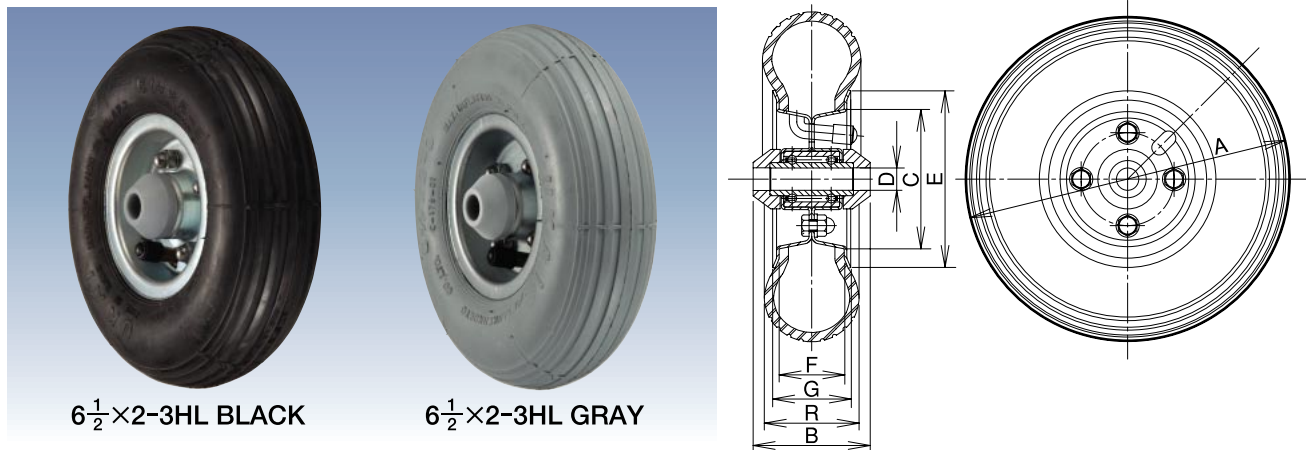

Model Number	Wheel	Load Capacity		Tire		Rim			Boss Width B	Shaft Diameter D	Standard Air Pressure (kgf/cm ²)	Steel Ball Bearing	Valve	Weight (g)	
		kg	daN	Diameter A	Width R	Diameter E	Bead Diameter C	Outside Width G							Inside Width F
6 1/2 x 2-3HL	BLACK GRAY	60	61.2	175	51	95	75	42	35	63	12	2.5	1230W	DIN7777	680 680

Unit: mm

Wheel: BLACK -- Tire Color : BLACK
GRAY -- Tire Color : GRAY

Tire: 4PR

The outer diameter and width of a tire were measured at the standard air pressure under the unloaded condition. They may vary according to usage conditions.

6 1/2 x 2-3HL PU PU Type Airless Tire (Foaming Urethane)

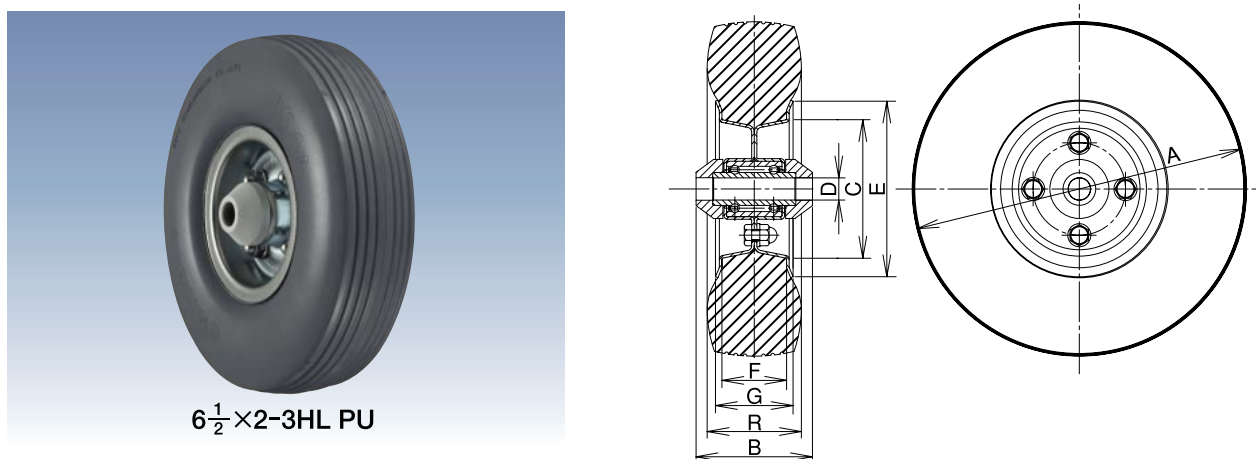

Model Number	Wheel	Load Capacity		Tire		Rim			Boss Width B	Shaft Diameter D	Standard Air Pressure (kgf/cm ²)	Steel Ball Bearing	Valve	Weight (g)	
		kg	daN	Diameter A	Width R	Diameter E	Bead Diameter C	Outside Width G							Inside Width F
6 1/2 x 2-3HL	PU	60	61.2	181	51	95	75	42	35	63	12	—	1230W	—	830

Unit: mm

The outer diameter and width of a tire were measured under the unloaded condition. They may vary according to usage conditions.

UKAI Pneumatic Wheels

Pneumatic Rubber Wheel / Airless Wheel

6 $\frac{1}{2}$ ×2-4HL (Boss Width : 52) Pneumatic Rubber Wheel



6 $\frac{1}{2}$ ×2-4HL BLACK

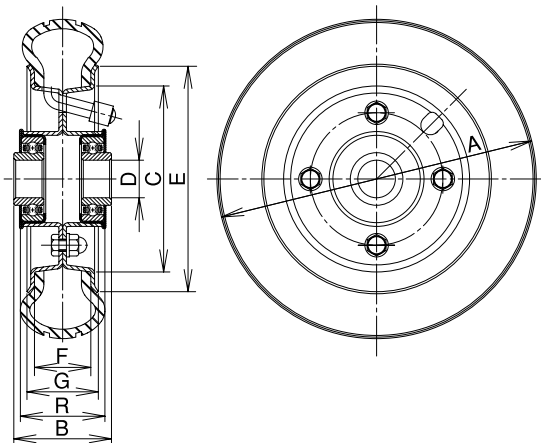

Model Number	Wheel	Load Capacity		Tire		Rim				Boss Width B	Shaft Diameter D	Standard Air Pressure (kgf/cm ²)	Steel Ball Bearing	Valve	Weight (g)
		kg	(daN)	Diameter A	Width R	Diameter E	Bead Diameter C	Outside Width G	Inside Width F						
		(kgf)													
6 $\frac{1}{2}$ ×2-4HL	BLACK	80	81.6	175	40	120	99	38	30	52	20	2.5	204B	DIN7777	1,060
	GRAY														1,060

Unit: mm

Wheel: BLACK -- Tire Color : BLACK
GRAY -- Tire Color : GRAY

Tire: 4PR

The outer diameter and width of a tire were measured at the standard air pressure under the unloaded condition. They may vary according to usage conditions.

6 $\frac{1}{2}$ ×2-4HF (Boss Width : 82) Pneumatic Rubber Wheel



6 $\frac{1}{2}$ ×2-4HF BLACK

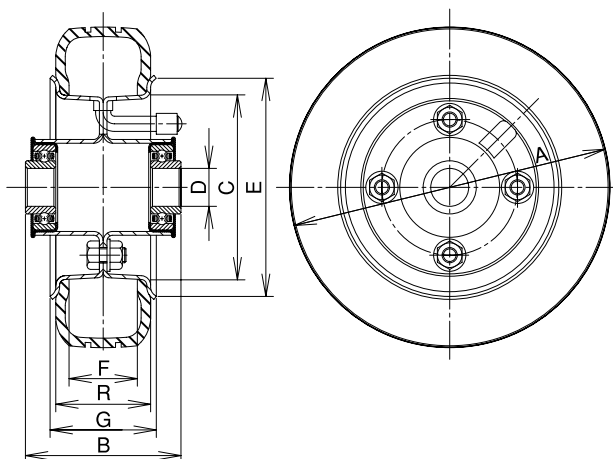

Model Number	Wheel	Load Capacity		Tire		Rim				Boss Width B	Shaft Diameter D	Standard Air Pressure (kgf/cm ²)	Steel Ball Bearing	Valve	Weight (g)
		kg	(daN)	Diameter A	Width R	Diameter E	Bead Diameter C	Outside Width G	Inside Width F						
		(kgf)													
6 $\frac{1}{2}$ ×2-4HF	BLACK	80	81.6	169	50	115	97.5	56	46	82	20	2.5	204B	DIN7777	1,270
	GRAY														1,270

Unit: mm

Wheel: BLACK -- Tire Color : BLACK
GRAY -- Tire Color : GRAY

Tire: 4PR

The outer diameter and width of a tire were measured at the standard air pressure under the unloaded condition. They may vary according to usage conditions.

UKAI Pneumatic Wheels

Pneumatic Rubber Wheel / Airless Wheel

2.00-4HL Pneumatic Rubber Wheel

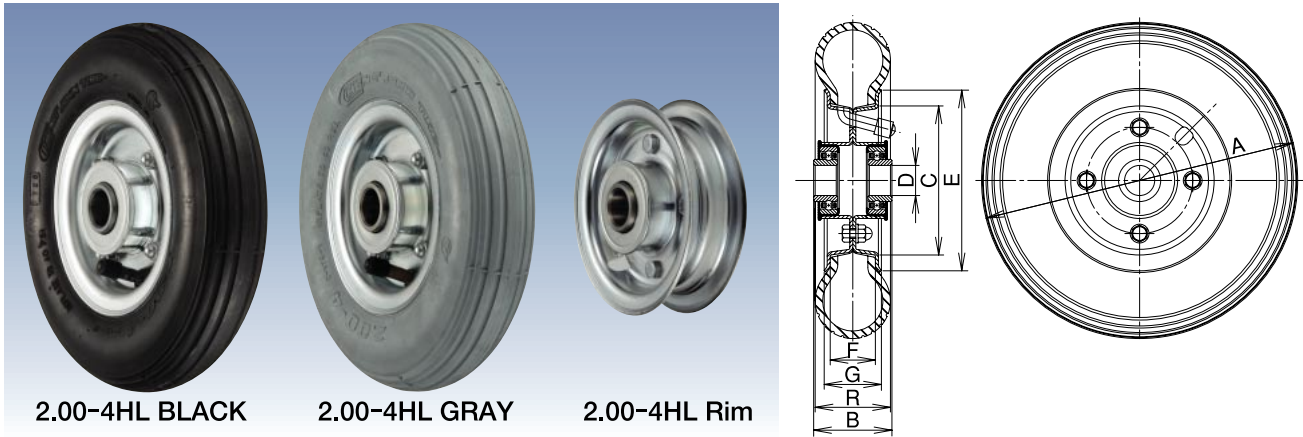

Unit: mm

Model Number	Wheel	Load Capacity		Tire		Rim				Boss Width B	Shaft Diameter D	Standard Air Pressure (kgf/cm ²)	Steel Ball Bearing	Valve	Weight (g)
		kg (daN)	kgf	A	R	Diameter E	Bead Diameter C	Outside Width G	Inside Width F						
2.00-4HL	BLACK	80	81.6	210	50	120	99	38	30	52	20	2.5	204B	JS87	1,110
	GRAY														1,110

Wheel: BLACK -- Tire Color : BLACK
GRAY -- Tire Color : GRAY

Tire: 4PR

The outer diameter and width of a tire were measured at the standard air pressure under the unloaded condition. They may vary according to usage conditions.

2.50-4HL Pneumatic Rubber Wheel / Airless Tire

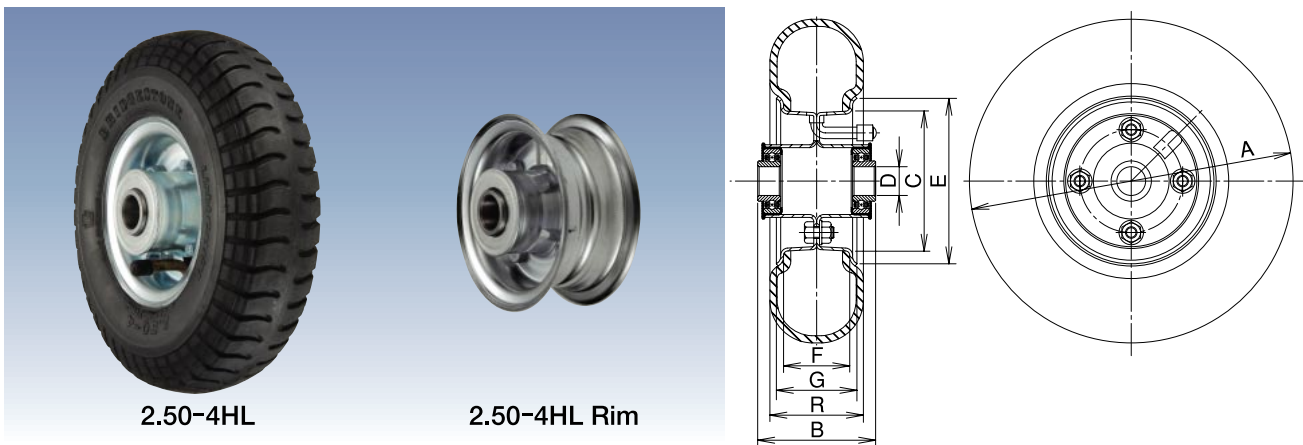

Unit: mm

Model Number	Wheel	Load Capacity		Tire		Rim				Boss Width B	Shaft Diameter D	Standard Air Pressure (kgf/cm ²)	Steel Ball Bearing	Valve	Weight (g)
		kg (daN)	kgf	A	R	Diameter E	Bead Diameter C	Outside Width G	Inside Width F						
2.50-4HL	BS	85	86.7	225	65	115	97.5	56	46	82	20	3.5	204B	TR87	1,550
	FO			218	62										1,460
	AL	100	102.0	220	60										—

Wheel: BS -- Tire Made by Bridgestone
FO -- Tire Made by an Overseas Maker
AL -- Airless / Solid Tire

Tire: 4PR

The outer diameter and width of a tire were measured at the standard air pressure under the unloaded condition. They may vary according to usage conditions.

UKAI Pneumatic Wheels

Pneumatic Rubber Wheel / Airless Wheel

3.00-4HL Pneumatic Rubber Wheel / Airless Tire



3.00-4HL

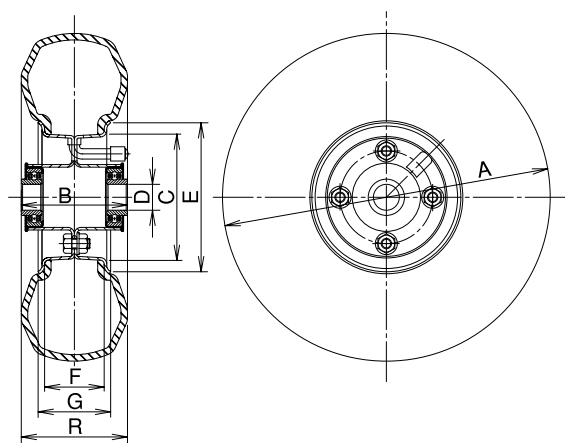

Model Number	Wheel	Load Capacity		Tire		Rim			Boss Width B	Shaft Diameter D	Standard Air Pressure (kgf/cm ²)	Steel Ball Bearing	Valve	Weight (g)	
		kg		Diameter A	Width R	Diameter E	Bead Diameter C	Outside Width G							Inside Width F
		(daN)	(kgf)	A	R	E	C	G							F
3.00-4HL	BS	110	112.2	253	82	115	97.5	56	46	82	20	3.5	204B	TR87	1,820
	FO			250	76										1,710
	AL	130	132.6	248	73										—

Unit: mm

Wheel: BS -- Tire Made by Bridgestone
FO -- Tire Made by an Overseas Maker
AL -- Airless / Solid Tire

Tire: 4PR

The outer diameter and width of a tire were measured at the standard air pressure under the unloaded condition. They may vary according to usage conditions.

8×3.00-4HL Pneumatic Rubber Wheel / Airless Tire



8×3.00-4HL

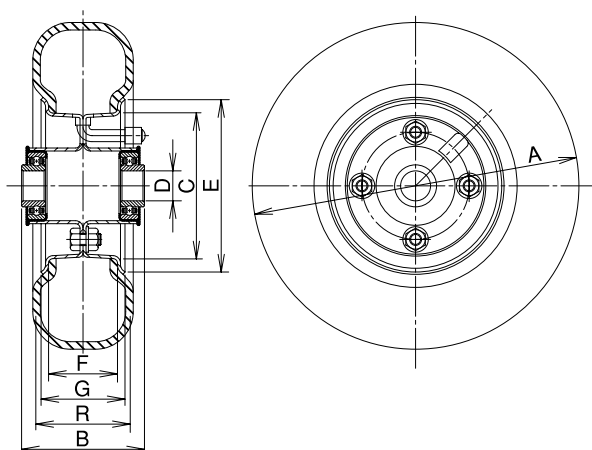

Model Number	Wheel	Load Capacity		Tire		Rim			Boss Width B	Shaft Diameter D	Standard Air Pressure (kgf/cm ²)	Steel Ball Bearing	Valve	Weight (g)	
		kg		Diameter A	Width R	Diameter E	Bead Diameter C	Outside Width G							Inside Width F
		(daN)	(kgf)	A	R	E	C	G							F
8×3.00-4HL	FO	85	86.7	218	67	115	97.5	56	46	82	20	3.5	204B	TR87	1,390
	AL	100	102.0	210	65										—

Unit: mm

Wheel: FO -- Tire Made by an Overseas Maker
AL -- Airless / Solid Tire

Tire: 4PR

The outer diameter and width of a tire were measured at the standard air pressure under the unloaded condition. They may vary according to usage conditions.

UKAI Pneumatic Wheels

Pneumatic Rubber Wheel / Airless Wheel

3.50-5HL Pneumatic Rubber Wheel / Airless Tire

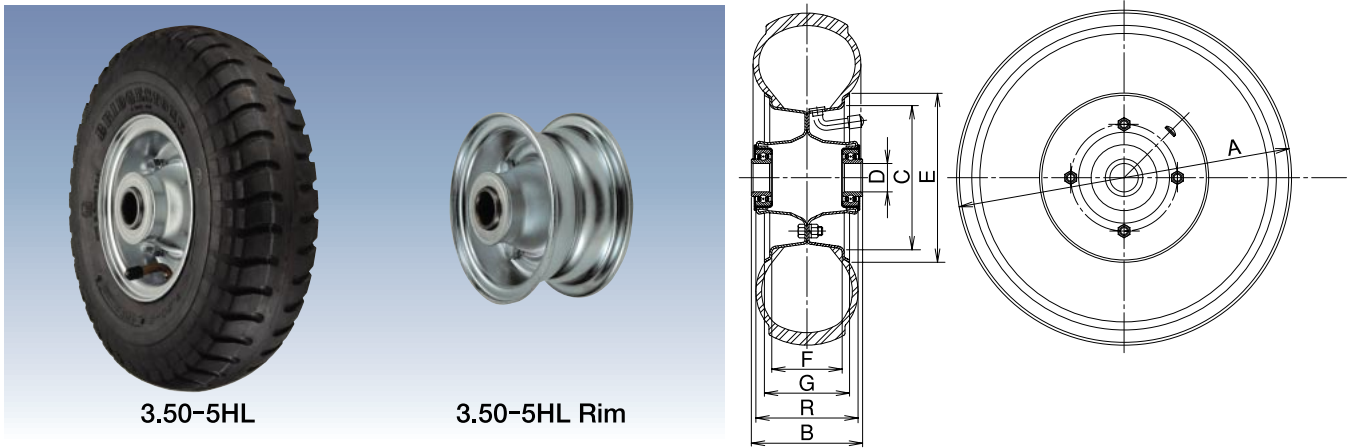

3.50-5HL

3.50-5HL Rim

Unit: mm

Model Number	Wheel	Load Capacity		Tire		Rim				Boss Width B	Shaft Diameter D	Standard Air Pressure (kgf/cm ²)	Steel Ball Bearing	Valve	Weight (g)
		kg	(daN)	Diameter A	Width R	Diameter E	Bead Diameter C	Outside Width G	Inside Width F						
3.50-5HL	BS	160	163.2	295	90	149	127	75	62	98	25	3.5	205B	JS87	2,610
	FO			286	90									TR87	2,610

Wheel: BS -- Tire Made by Bridgestone
FO -- Tire Made by an Overseas Maker

Tire: 4PR

The outer diameter and width of a tire were measured at the standard air pressure under the unloaded condition. They may vary according to usage conditions.

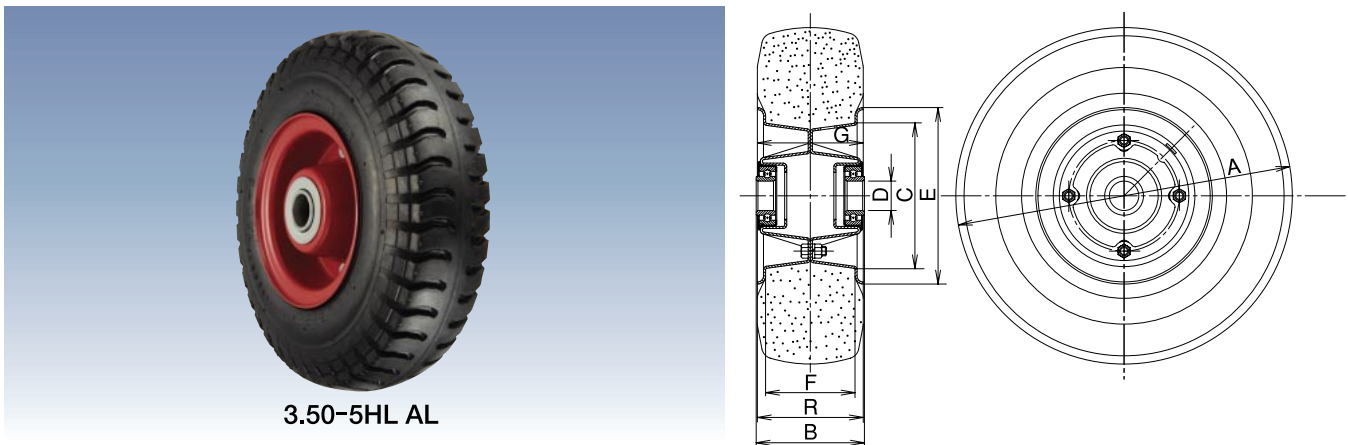

3.50-5HL AL

Unit: mm

Model Number	Wheel	Load Capacity		Tire		Rim				Boss Width B	Shaft Diameter D	Standard Air Pressure (kgf/cm ²)	Steel Ball Bearing	Valve	Weight (g)
		kg	(daN)	Diameter A	Width R	Diameter E	Bead Diameter C	Outside Width G	Inside Width F						
3.50-5HL	AL	200	204.0	286	90	150	124	90	76	92	25	—	CBB-2547R	—	5,940

Wheel: AL -- Airless / Solid Tire

The outer diameter and width of a tire were measured under the unloaded condition. They may vary according to usage conditions.

Pneumatic Wheel Parts

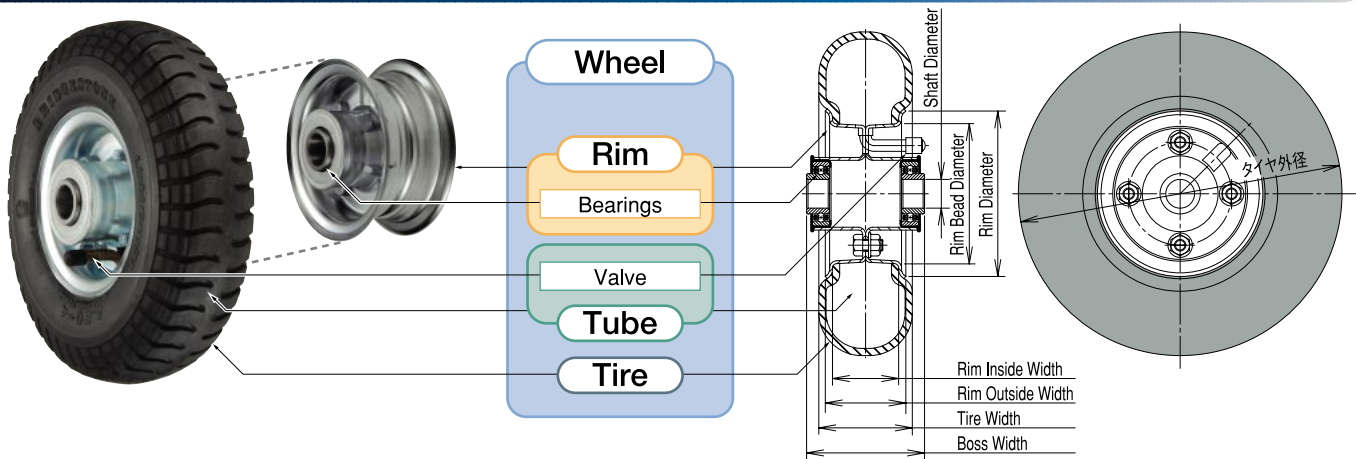

The Model Number of UKAI Pneumatic Wheels

6 1/2 Tire Diameter 6 1/2 inch	×	2 Tire Width 2 inch	-	3 Rim Inside Width 3 inch	HL HubLess	4PR Ply Rating (Tire Strength)
2.00 Tire Diameter 2 inch			-	4 Rim Inside Width 4 inch	HL HubLess	4PR Ply Rating (Tire Strength)

* 1 inch = 25.4 cm For actual size, refer to the table of specs on each page.

The Usage Notice of Pneumatic / Airless Wheels

- Check the abrasion or deterioration of the tire part of the pneumatic rubber / airless wheel, the corrosion of the bearing part, etc. If you discover deterioration, replace the parts.
- The pneumatic rubber wheel may deflate spontaneously. Check air pressure, and if it is low, replenish air.
- Regarding air replenishment
The Schrader Valve (American Valve) is used for the pneumatic rubber wheel. When replenishing air, use an inflator for the Schrader Valve (American Valve). It is impossible to replenish air with other inflators for such as Dunlop Valve (English Valve).
- If air leaks after air replenishment
In the case of air leakage after air replenishment, possible factors include the damage to the tube and the loosening of the valve core. Check each part, to confirm whether there is the leakage of air. If the valve core loosens, tighten it again.

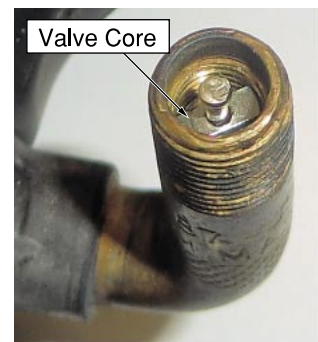

Schrader Valve (American Valve)

If there are any questions, please ask us before use.

The Performance Test of Casters

Static Load Test

Apply a load of three times the maximum load written in the catalog on the caster for 3 minutes, to check abnormalities. It will provide reference data for load bearing capacity.

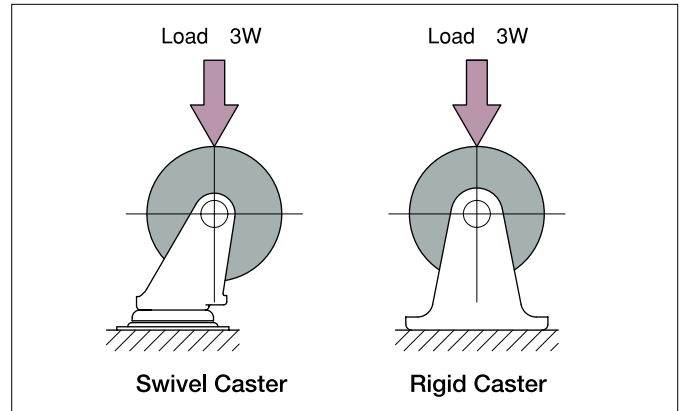

Running Test

Apply the maximum load on the caster and roll it on a rugged steel drum for a certain distance, to check wheel performance. It will provide reference data for the rolling performance of a wheel.

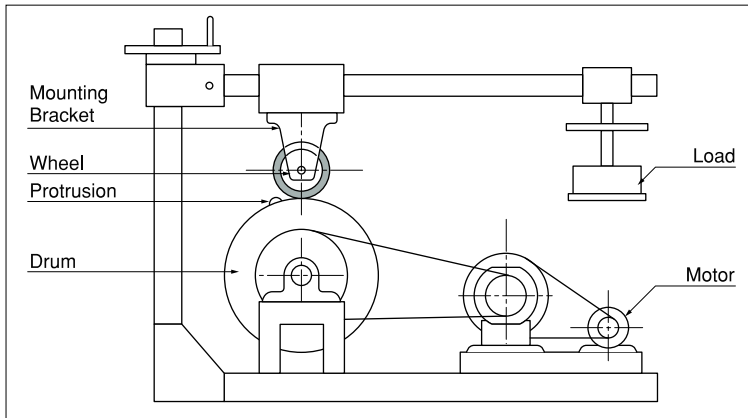

Starting Performance Test

Attach casters to a cart, and place a load onto the cart. Then, measure starting resistance. You can check starting performance and swivel starting performance.

Starting Performance

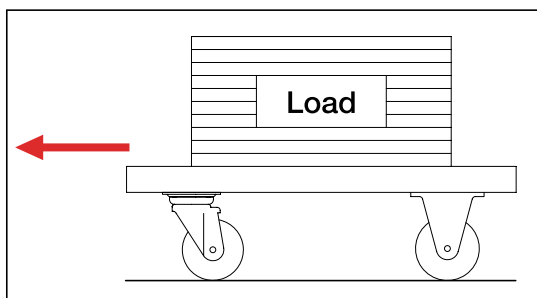

Swivel Starting Performance

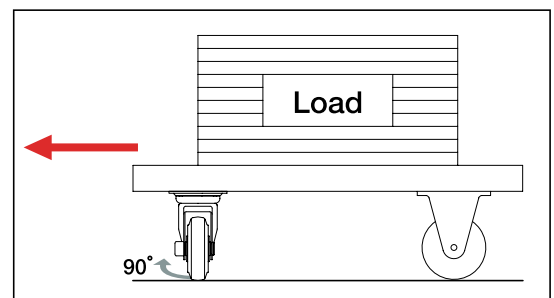



岐阜産研工業株式会社
Gifu Sanken Kogyo Co.,Ltd.

Homepage URL <http://www.gifusanken.com/>

Ukai Caster Catalog URL <http://www.gifusanken.com/cataj0701/>

You can download the catalog and CAD data
from our homepage.

- **Ogaki Factory** **Caster Division**
696 Hirui-Cho, Ogaki-City, Gifu-Pref. 503-2216, Japan
TEL: +81-584-93-2975 FAX:+81- 584-93-2976

- **Head Office** **Moulding Division**
1403 Kugo, Ono-Cho, Ibi-Gun, Gifu-Pref. 501-0555, Japan
TEL: +81-585-35-2529 FAX:+81- 585-35-2526

- **Gift Division** 755-3 Honjo, Ono-Cho, Ibi-Gun, Gifu-Pref. 501-0533, Japan
TEL: +81-585-35-2511 FAX:+81- 585-35-2327

Dealer / Agency

- The specs of the products in this catalog may be modified without notice, with the purpose of improving quality or the like.
We would appreciate your understanding.
- The colors of actual products may differ from those in this catalog somewhat.
We would appreciate your understanding.
- You cannot reprint this document without our consent.